

**SIEMENS**



# SIPART

Electropneumatic positioners  
SIPART PS2 with and without HART

Operating Instructions

Edition

06/2013

Answers for industry.



# SIEMENS

## SIPART

### Electropneumatic positioners SIPART PS2 with and without HART

#### Operating Instructions

6DR50.. - Positioner without HART  
6DR51.. - Positioner with HART, not explosion-proof  
6DR52.. - Positioner with HART, explosion-proof  
6DR53.. - Positioner without HART, not explosion-proof

06/2013



A5E00074631-10

Introduction	1
Safety information	2
Description	3
Installing/mounting	4
Connection	5
Operating	6
Commissioning	7
Functional safety	8
Parameterizing/addressing	9
Alarm, error, and system messages	10
Service and maintenance	11
Technical data	12
Dimension drawings	13
Spare parts/accessories/scope of delivery	14
Appendix	A
Abbreviations	B

## Legal information

### Warning notice system

This manual contains notices you have to observe in order to ensure your personal safety, as well as to prevent damage to property. The notices referring to your personal safety are highlighted in the manual by a safety alert symbol, notices referring only to property damage have no safety alert symbol. These notices shown below are graded according to the degree of danger.

 <b>DANGER</b>
indicates that death or severe personal injury <b>will</b> result if proper precautions are not taken.
 <b>WARNING</b>
indicates that death or severe personal injury <b>may</b> result if proper precautions are not taken.
 <b>CAUTION</b>
indicates that minor personal injury can result if proper precautions are not taken.
<b>NOTICE</b>
indicates that property damage can result if proper precautions are not taken.

If more than one degree of danger is present, the warning notice representing the highest degree of danger will be used. A notice warning of injury to persons with a safety alert symbol may also include a warning relating to property damage.

### Qualified Personnel

The product/system described in this documentation may be operated only by **personnel qualified** for the specific task in accordance with the relevant documentation, in particular its warning notices and safety instructions. Qualified personnel are those who, based on their training and experience, are capable of identifying risks and avoiding potential hazards when working with these products/systems.

### Proper use of Siemens products

Note the following:

 <b>WARNING</b>
Siemens products may only be used for the applications described in the catalog and in the relevant technical documentation. If products and components from other manufacturers are used, these must be recommended or approved by Siemens. Proper transport, storage, installation, assembly, commissioning, operation and maintenance are required to ensure that the products operate safely and without any problems. The permissible ambient conditions must be complied with. The information in the relevant documentation must be observed.

### Trademarks

All names identified by ® are registered trademarks of Siemens AG. The remaining trademarks in this publication may be trademarks whose use by third parties for their own purposes could violate the rights of the owner.

### Disclaimer of Liability

We have reviewed the contents of this publication to ensure consistency with the hardware and software described. Since variance cannot be precluded entirely, we cannot guarantee full consistency. However, the information in this publication is reviewed regularly and any necessary corrections are included in subsequent editions.

# Table of contents

<b>1</b>	<b>Introduction</b> .....	<b>9</b>
1.1	Purpose of this documentation .....	9
1.2	History .....	9
1.3	Purpose.....	9
1.4	Checking the consignment.....	10
1.5	Transportation and storage.....	10
1.6	Product information.....	11
1.7	Notes on warranty.....	11
<b>2</b>	<b>Safety information</b> .....	<b>13</b>
2.1	Requirements for safe use.....	13
2.1.1	Warning symbols on the device.....	13
2.1.2	Laws and directives .....	13
2.1.3	Conformity with European directives .....	14
2.2	Improper device modifications .....	14
2.3	Requirements for special applications .....	15
2.4	Use in hazardous areas .....	15
2.5	SIL applications.....	16
<b>3</b>	<b>Description</b> .....	<b>17</b>
3.1	Function .....	17
3.2	Structure.....	17
3.2.1	Overview of structure .....	17
3.2.2	Design of the nameplate .....	20
3.3	Device components .....	22
3.3.1	Overview of device components.....	22
3.3.2	Basic electronics .....	23
3.4	Mode of operation .....	24
3.4.1	Control algorithm.....	25
3.4.2	Block circuit diagram for signal-acting or dual-acting drives.....	26
3.4.3	Mode of operation of the HART function .....	27
<b>4</b>	<b>Installing/mounting</b> .....	<b>29</b>
4.1	Basic safety instructions .....	29
4.1.1	Proper mounting.....	32
4.2	Mounting the linear actuator .....	32
4.3	Mounting the part-turn actuator.....	38
4.4	Using the positioner in a humid environment.....	43

4.5	Positioners subjected to fast acceleration or strong vibration.....	45
4.5.1	Introduction locking the setting .....	45
4.5.2	Procedure locking the setting.....	45
4.6	External position detection .....	48
4.7	Installing option modules.....	49
4.7.1	General information on installing option modules .....	49
4.7.1.1	Installing optional modules in the standard and intrinsically safe version .....	49
4.7.1.2	Installing the optional modules in the "flameproof enclosure" version.....	52
4.7.2	ly module.....	56
4.7.3	Alarm unit .....	57
4.7.4	Slot initiator alarm module.....	59
4.7.4.1	Setting the limits of the slotted initiator alarm unit .....	61
4.7.5	Mechanical limit switch module.....	62
4.7.5.1	Setting the limits of the mechanical limit switch module .....	64
4.7.5.2	Label set for limit contact module .....	65
4.7.6	EMC filter module.....	65
4.7.7	Accessories .....	68
<b>5</b>	<b>Connection .....</b>	<b>69</b>
5.1	Electric.....	69
5.1.1	Basic safety instructions.....	69
5.1.1.1	Standard cable gland/torque .....	73
5.1.2	Electrical connections .....	73
5.1.3	Device without Ex protection/Device with Ex d type of protection .....	74
5.1.3.1	Basic device without Ex protection / in flameproof enclosure "Ex d".....	74
5.1.3.2	Split range without Ex protection / in flameproof enclosure "Ex d".....	76
5.1.3.3	Option modules without Ex protection / in flameproof enclosure "Ex d".....	77
5.1.4	Device with Ex i/Ex n/Ex t type of protection.....	82
5.1.4.1	Basic device Ex i/Ex n/Ex t.....	83
5.1.4.2	Split range Ex i/Ex n/Ex t.....	85
5.1.4.3	Option modules Ex i/Ex n/Ex t.....	86
5.1.5	Connecting NCS to EMC filter module.....	91
5.1.6	Connecting the external position detection system to the EMC filter module.....	92
5.2	Pneumatic .....	95
5.2.1	Pneumatic connections .....	95
5.2.1.1	Pneumatic connection on the standard controller.....	95
5.2.1.2	Integrated pneumatic connection .....	95
5.2.1.3	Pneumatic connection in the flameproof enclosure .....	96
5.2.1.4	Pneumatic connection versions .....	97
5.2.2	Pneumatic connection.....	99
5.3	Restrictors .....	100
<b>6</b>	<b>Operating.....</b>	<b>101</b>
6.1	Operating elements.....	101
6.1.1	Display.....	101
6.1.2	Buttons .....	102
6.1.3	Firmware version.....	104
6.2	Operating modes.....	104
6.2.1	Overview of operating modes .....	104
6.2.2	Changing the operating mode.....	105

6.2.3	Overview of configuration .....	106
6.2.4	Description of operating modes .....	106
6.3	Optimizing the controller data .....	109
<b>7</b>	<b>Commissioning .....</b>	<b>111</b>
7.1	Basic safety instructions .....	111
7.2	Sequence of automatic initialization .....	115
7.3	Purge air switching.....	120
7.4	Commissioning linear actuators.....	121
7.4.1	Preparing linear actuators for commissioning.....	121
7.4.2	Automatic initialization of linear actuators.....	122
7.4.3	Manual initialization of linear actuators.....	125
7.5	Commissioning part-turn actuators .....	129
7.5.1	Preparing part-turn actuators for commissioning.....	129
7.5.2	Automatic initialization of part-turn actuators.....	130
7.5.3	Manual initialization of part-turn actuators .....	132
7.6	Device replacement .....	135
<b>8</b>	<b>Functional safety.....</b>	<b>137</b>
8.1	General Safety Notes.....	137
8.1.1	Safety Integrity Level (SIL).....	138
8.2	Device-specific safety instructions .....	139
8.2.1	Range of applications for functional safety .....	139
8.2.2	Safety function .....	140
8.2.3	Settings .....	141
8.2.4	Behavior in case of faults .....	142
8.2.5	Maintenance/Checking .....	142
8.2.6	Safety characteristics .....	143
<b>9</b>	<b>Parameterizing/addressing.....</b>	<b>145</b>
9.1	Parameter chapter .....	145
9.2	Configuration schematic for parameter operating principle .....	146
9.3	Overview of parameters.....	147
9.3.1	Overview of parameters 1 to 5.....	147
9.3.2	Overview of parameters 6 to 51.....	148
9.3.3	Overview parameters A to P.....	151
9.4	Description of parameters.....	155
9.4.1	Description of parameters 1 through 5 .....	155
9.4.2	Description of parameters 6 through 51 .....	157
9.4.2.1	Description of parameters 6.....	157
9.4.2.2	Description of parameters 7.....	158
9.4.2.3	Description of parameters 8 and 9.....	159
9.4.2.4	Description of parameters 10 and 11.....	160
9.4.2.5	Description of parameters 12.....	160
9.4.2.6	Description of parameters 13 through 33 .....	161
9.4.2.7	Description of parameters 34.....	161
9.4.2.8	Description of parameters 35 and 36.....	162

9.4.2.9	Description of parameters 37 .....	162
9.4.2.10	Description of parameters 38 .....	164
9.4.2.11	Description of parameters 39 .....	164
9.4.2.12	Description of parameters 40 and 41 .....	165
9.4.2.13	Description of parameters 42 and 43 .....	165
9.4.2.14	Description of parameters 44 .....	166
9.4.2.15	Description of parameters 45 and 46 .....	167
9.4.2.16	Description of parameters 47 .....	168
9.4.2.17	Description of parameters 48 .....	169
9.4.2.18	Description of parameters 49 .....	169
9.4.2.19	Description of parameters 50 .....	170
9.4.2.20	Description of parameters 51 .....	170
9.4.3	Description of parameters A through P .....	172
9.4.3.1	Description of parameter A .....	172
9.4.3.2	Description of parameter b .....	175
9.4.3.3	Description of parameter C .....	176
9.4.3.4	Description of parameter d .....	179
9.4.3.5	Description of parameter E .....	180
9.4.3.6	Description of parameter F .....	181
9.4.3.7	Description of parameter G .....	182
9.4.3.8	Description of parameter H .....	184
9.4.3.9	Description of parameter J .....	185
9.4.3.10	Description of parameter L .....	186
9.4.3.11	Description of parameter O .....	187
9.4.3.12	Description of parameter P .....	189
<b>10</b>	<b>Alarm, error, and system messages .....</b>	<b>191</b>
10.1	Output of system messages in the display .....	191
10.1.1	System messages before initialization .....	191
10.1.2	System messages during initialization .....	192
10.1.3	System messages when exiting the Configuration mode .....	195
10.1.4	System messages during operation .....	195
10.2	Diagnosis .....	197
10.2.1	Display of diagnostics values .....	197
10.2.2	Overview of diagnostics values .....	197
10.2.3	Meaning of the diagnostics values .....	200
10.2.4	Meaning of diagnostic value 53 .....	207
10.3	Online diagnostics .....	207
10.3.1	Overview of online diagnostics .....	207
10.3.2	Overview of error codes .....	208
10.3.3	XDIAG parameter .....	209
10.3.4	Meaning of error codes .....	210
10.4	Fault correction .....	213
10.4.1	Fault identification .....	213
10.4.2	Remedial measures table 1 .....	214
10.4.3	Remedial measures table 2 .....	215
10.4.4	Remedial measures table 3 .....	216
10.4.5	Remedial measures table 4 .....	217
10.4.6	Remedial measures table 5 .....	218
<b>11</b>	<b>Service and maintenance .....</b>	<b>219</b>



11.1	Basic safety instructions .....	219
11.2	Cleaning of the screens .....	220
11.2.1	Positioner in macrolon enclosure .....	220
11.2.2	Positioner in stainless steel, aluminum and flameproof aluminum enclosure .....	221
11.3	Repair/Upgrading .....	221
11.4	Return procedure .....	222
<b>12</b>	<b>Technical data .....</b>	<b>223</b>
12.1	Rated conditions .....	223
12.2	Pneumatic data .....	224
12.3	Construction .....	225
12.4	Electrical data.....	227
12.5	Controller.....	229
12.6	Certificates, approvals, explosion protection for all device versions .....	229
12.7	Technical data for natural gas as actuator medium.....	231
12.8	Option modules .....	232
12.8.1	Alarm module .....	232
12.8.2	ly module.....	233
12.8.3	SIA module.....	234
12.8.4	Limit value contact module .....	235
12.8.5	EMC filter module.....	236
12.8.6	Non-contacting position sensor.....	236
12.8.7	External position sensing system.....	238
12.8.7.1	Operating conditions for all device versions .....	238
12.8.7.2	Constructional design for all device versions.....	238
12.8.7.3	Certificates, approvals, explosion protection for all device versions .....	239
<b>13</b>	<b>Dimension drawings.....</b>	<b>241</b>
13.1	Positioner with Makrolon enclosure 6DR5..0 and stainless steel enclosure 6DR5..2 .....	241
13.2	Terminal strip for positioner with Macrolon enclosure .....	242
13.3	Positioner with aluminum enclosure 6DR5..1 .....	243
13.4	Positioner with flameproof enclosure 6DR5..5.....	244
<b>14</b>	<b>Spare parts/accessories/scope of delivery.....</b>	<b>245</b>
14.1	Overview .....	245
14.2	Spare parts.....	247
14.3	Scope of delivery of small part sets .....	249
14.4	Scope of delivery of external position detection system.....	251
14.5	Scope of delivery of mechanical limit switch module.....	251
14.6	Scope of delivery EMC filter module.....	252
14.7	Accessories.....	253
<b>A</b>	<b>Appendix.....</b>	<b>255</b>

*Table of contents*

---

A.1	Operation with boosters .....	255
A.2	Literature and catalogs.....	256
A.3	Certificate .....	256
A.4	Technical support.....	257
<b>B</b>	<b>Abbreviations .....</b>	<b>259</b>
	<b>Glossary .....</b>	<b>263</b>
	<b>Index .....</b>	<b>271</b>

## Introduction

### 1.1 Purpose of this documentation

These instructions contain all information required to commission and use the device. It is your responsibility to read the instructions carefully prior to installation and commissioning. In order to use the device correctly, first review its principle of operation.

The instructions are aimed at persons mechanically installing the device, connecting it electronically, configuring the parameters and commissioning it, as well as service and maintenance engineers.

### 1.2 History

This history establishes the correlation between the current documentation and the valid firmware of the device.

The documentation of this edition is applicable for the following firmware:

Edition	Firmware code
10 06/2013	FW from 4.00.00

The most important changes in the documentation when compared with the respective previous edition are given in the following table.

Edition	Remark
10 06/2013	Revision of the safety information. "Installing/Mounting > Option modules" chapter "Functional safety" chapter "Technical data" chapter "Appendix" chapter

### 1.3 Purpose

The electropneumatic positioner is used for the continuous control of process valves with pneumatic drives in the following industries.

- Chemicals
- Oil and gas
- Energy production
- Food and beverages

1.4 Checking the consignment

- Pulp and paper
- Water/waste water
- Pharmaceutical industry
- Offshore plants

Operate the device according to the specifications in Chapter "Technical data (Page 223)".

For additional information, refer to the operating instructions for the device.

## 1.4 Checking the consignment

1. Check the packaging and the device for visible damage caused by inappropriate handling during shipping.
2. Report any claims for damages immediately to the shipping company.
3. Retain damaged parts for clarification.
4. Check the scope of delivery by comparing your order to the shipping documents for correctness and completeness.

 <b>WARNING</b>
<b>Using a damaged or incomplete device</b> Danger of explosion in hazardous areas. <ul style="list-style-type: none"><li>• Do not use damaged or incomplete devices.</li></ul>

## 1.5 Transportation and storage

To guarantee sufficient protection during transport and storage, observe the following:

- Keep the original packaging for subsequent transportation.
- Devices/replacement parts should be returned in their original packaging.
- If the original packaging is no longer available, ensure that all shipments are properly packaged to provide sufficient protection during transport. Siemens cannot assume liability for any costs associated with transportation damages.

 <b>CAUTION</b>
<b>Insufficient protection during storage</b> The packaging only provides limited protection against moisture and infiltration. <ul style="list-style-type: none"><li>• Provide additional packaging as necessary.</li></ul>

Special conditions for storage and transportation of the device are listed in "Technical data" (Page 223).

## 1.6 Product information

The programming manual is an integral part of the CD, which is either supplied or can be ordered. The programming manual is also available on the Siemens homepage.

On the CD, you will also find the catalog extract with the ordering data, the Software Device Install for SIMATIC PDM for additional installation, and the required software.

### See also

SIPART PS2 product information (<http://www.siemens.com/sipartps2>)

Contacts (<http://www.siemens.com/processinstrumentation/contacts>)

Process instrumentation catalog (<http://www.siemens.com/processinstrumentation/catalogs>)

## 1.7 Notes on warranty

The contents of this manual shall not become part of or modify any prior or existing agreement, commitment or legal relationship. The sales contract contains all obligations on the part of Siemens as well as the complete and solely applicable warranty conditions. Any statements regarding device versions described in the manual do not create new warranties or modify the existing warranty.

The content reflects the technical status at the time of publishing. Siemens reserves the right to make technical changes in the course of further development.







## Safety information

### 2.1 Requirements for safe use

This device left the factory in good working condition. In order to maintain this status and to ensure safe operation of the device, observe these instructions and all the specifications relevant to safety.

Observe the information and symbols on the device. Do not remove any information or symbols from the device. Always keep the information and symbols in a completely legible state.

#### 2.1.1 Warning symbols on the device

Symbol	Meaning
	Consult operating instructions
	Hot surface
	Isolate the device from power using a circuit-breaker
	Protect the device from shocks (otherwise the specified degree of protection is not guaranteed)
	Protective insulation; device in protection class II

#### 2.1.2 Laws and directives

Observe the test certification, provisions and laws applicable in your country during connection, assembly and operation. These include, for example:

- National Electrical Code (NEC - NFPA 70) (USA)
- Canadian Electrical Code (CEC) (Canada)

Further provisions for hazardous area applications are for example:

## 2.2 Improper device modifications

- IEC 60079-14 (international)
- EN 60079-14 (EC)

### See also

Certificates (<http://www.siemens.com/processinstrumentation/certificates>)

### 2.1.3 Conformity with European directives

The CE marking on the device shows conformity with the regulations of the following European guidelines:

Electromagnetic  
Compatibility EMC  
2004/108/EC

Directive of the European Parliament and of the Council on the approximation of the laws of the Member States relating to electromagnetic compatibility and repealing Directive 89/336/EEC.

Atmosphère explosible  
ATEX  
94/9/EC

Directive of the European Parliament and the Council on the approximation of the laws of the Member States concerning equipment and protective systems intended for use in potentially explosive atmospheres.

The applied standards can be found in the EC conformity declaration of the device.

## 2.2 Improper device modifications

 <b>WARNING</b>
<b>Improper device modifications</b> Danger to personnel, system and environment can result from modifications to the device, particularly in hazardous areas. <ul style="list-style-type: none"><li>• Only carry out modifications that are described in the instructions for the device. Failure to observe this requirement cancels the manufacturer's warranty and the product approvals.</li></ul>



## 2.3 Requirements for special applications

Due to the large number of possible applications, each detail of the described device versions for each possible scenario during commissioning, operation, maintenance or operation in systems cannot be considered in the instructions. If you need additional information not covered by these instructions, contact your local Siemens office or company representative.

---

### Note

#### Operation under special ambient conditions

We highly recommend that you contact your Siemens representative or our application department before you operate the device under special ambient conditions as can be encountered in nuclear power plants or when the device is used for research and development purposes.

---

## 2.4 Use in hazardous areas

### Qualified personnel for hazardous area applications

Persons who install, assemble, commission, operate and service the device in a hazardous area must have the following specific qualifications:

- They are authorized, trained or instructed in operating and maintaining devices and systems according to the safety regulations for electrical circuits, high pressures, aggressive and hazardous media.
- They are authorized, trained, or instructed in carrying out work on electrical circuits for hazardous systems.
- They are trained or instructed in maintenance and use of appropriate safety equipment according to the pertinent safety regulations.

 <b>WARNING</b>
<b>Unsuitable device for the hazardous area</b> Danger of explosion. <ul style="list-style-type: none"><li>• Only use equipment that is approved for use in the intended hazardous area and labelled accordingly.</li></ul>

 <b>WARNING</b>
<b>Loss of safety of device with type of protection "Intrinsic safety Ex i"</b>
If the device has already been operated in non-intrinsically safe circuits or the electrical specifications have not been observed, the safety of the device is no longer ensured for use in hazardous areas. There is a danger of explosion.
<ul style="list-style-type: none"><li>• Connect the device with type of protection "Intrinsic safety" solely to an intrinsically safe circuit.</li><li>• Observe the specifications for the electrical data on the certificate and in Chapter "Technical data (Page 223)".</li></ul>

## 2.5 SIL applications

Single-acting SIPART PS2 positioners with 4 to 20 mA are suitable for safely depressurizing the pneumatic air outlet Y1 ("Shutdown"). The device versions 6DR501., 6DR511., 6DR521. and 6DR531. can be used in a technical safety system up to safety integrity level (SIL) 2.

### See also

Functional safety in process instrumentation (<http://www.siemens.com/SIL>)

## Description

### 3.1 Function

- The electropneumatic positioner, in combination with the drive, forms a regulation system. The current position of the actuator is detected using a potentiometer and returned as the actual value  $x$ . The setpoint and actual value are output simultaneously on the display.
- The setpoint  $w$  forms a current applied to the positioner, which in two-wire mode is also used to power the positioner. In 3- and 4-wire mode, power is supplied through a 24-V power input.
- The positioner works as a predictive five-point positioner, through whose output value  $\pm\Delta y$  the integrated valves can be controlled by pulse length modulation.
- These positioning signals cause pressure changes in the drive chamber(s) and thus a repositioning of the drive until the regulation deviation returns to zero.
- Using three buttons and the display with the enclosure cover removed, operation (manual mode) and configuration (structuring, initialization, and parameter assignment) can be performed.
- By default, the basic unit has a binary input (BE1). This binary input can be individually configured and used e.g. to block the control levels.
- To be able to use the positioner in a variety of mechanically different rotational and linear actuators, it has a friction clutch and a switchable gear.

### 3.2 Structure

#### 3.2.1 Overview of structure

The following sections describe the mechanical and electrical structure, components, and principle functionality of the positioner.

The positioner is available in the following configurations:

- SIPART PS2 without explosion protection in stainless steel, aluminum or Makrolon enclosure
- SIPART PS2 with Ex i protection in stainless steel, aluminum or Makrolon enclosure
- SIPART PS2 with Ex d protection in flameproof aluminum enclosure

The positioner is used to move and control pneumatic actuators. The positioner works electropneumatically, using compressed air as auxiliary power. The positioner is used to control valves, for example, with:

- Linear actuator
- Part-turn actuator VDI/VDE 3845

Various add-on extensions are available for linear actuators:

- IEC 60534-6-1 (NAMUR)
- Integrated addition to ARCA
- Integrated addition to SAMSON in non-flameproof aluminum enclosure



- ① Pressure gauge block, single-acting
- ② Valve
- ③ Yoke / actuator yoke
- ④ Single-acting positioner in non-flameproof aluminum enclosure
- ⑤ Actuator

Figure 3-1 Positioner attached to a single-acting linear actuator

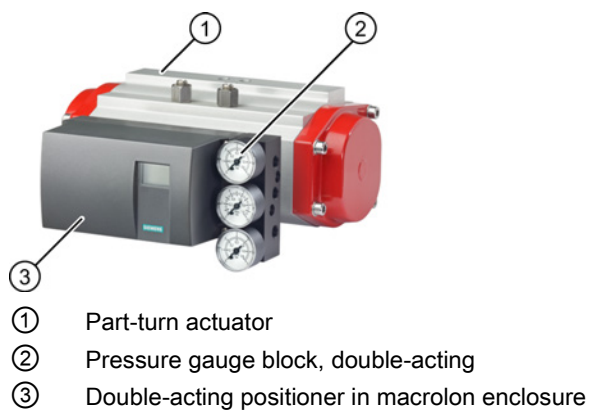

Figure 3-2 Positioner attached to double-acting part-turn actuator

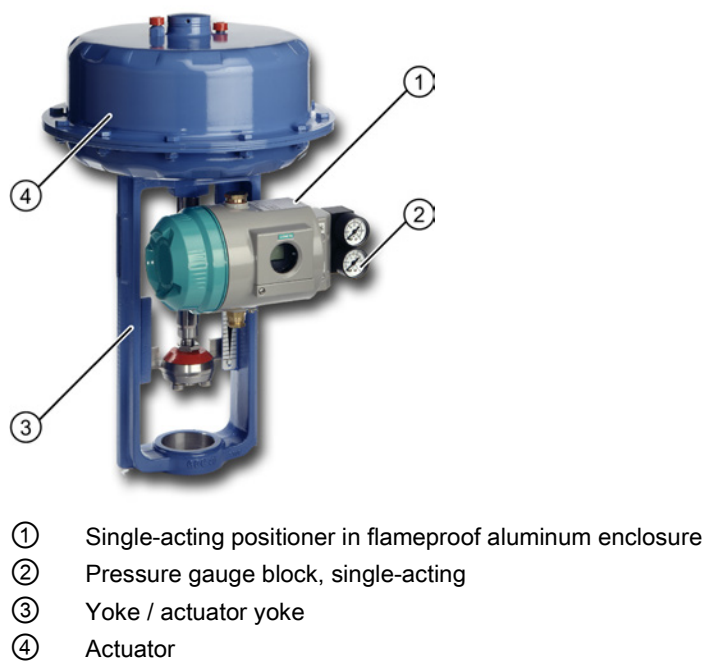
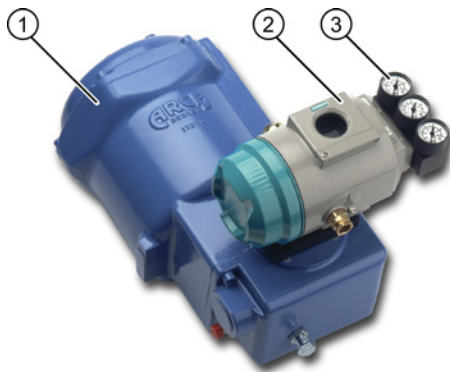

Figure 3-3 Positioner in flameproof aluminum enclosure attached to linear actuator

3.2 Structure



- ① Part-turn actuator
- ② Double-acting positioner in flameproof aluminum enclosure
- ③ Pressure gauge block, double-acting

Figure 3-4 Positioner in flameproof aluminum enclosure attached to part-turn actuator

3.2.2 Design of the nameplate

Design of the nameplate

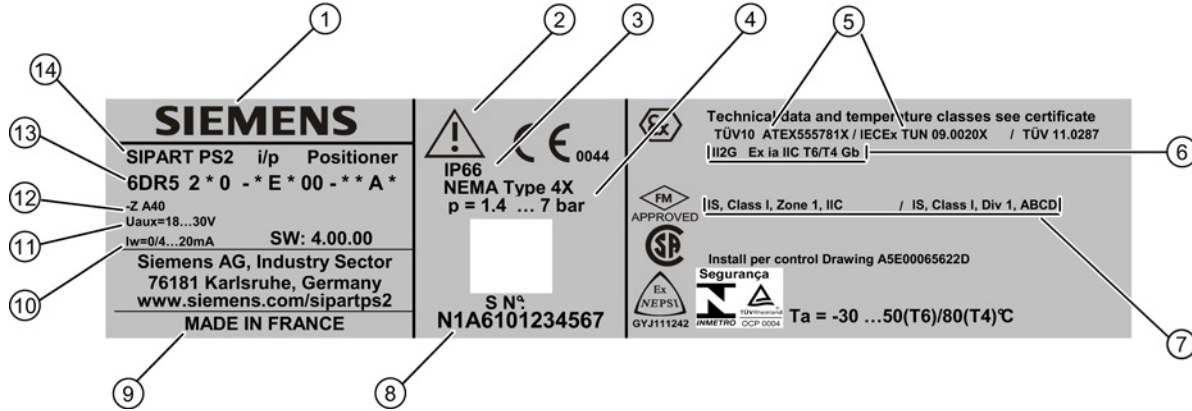

- ① Manufacturer
- ② Consult operating instructions
- ③ Safety class
- ④ Auxiliary power (air supply)
- ⑤ Approvals
- ⑥ ATEX/IECEx marking for hazardous area
- ⑦ FM/CSA marking for hazardous area
- ⑧ Manufacturer serial number
- ⑨ Place of manufacture
- ⑩ Rated signal range
- ⑪ Auxiliary power supply
- ⑫ Ordering supplement (Order code)
- ⑬ Order number
- ⑭ Product name

Figure 3-5 Nameplate layout, example

## Explanation of Ex information

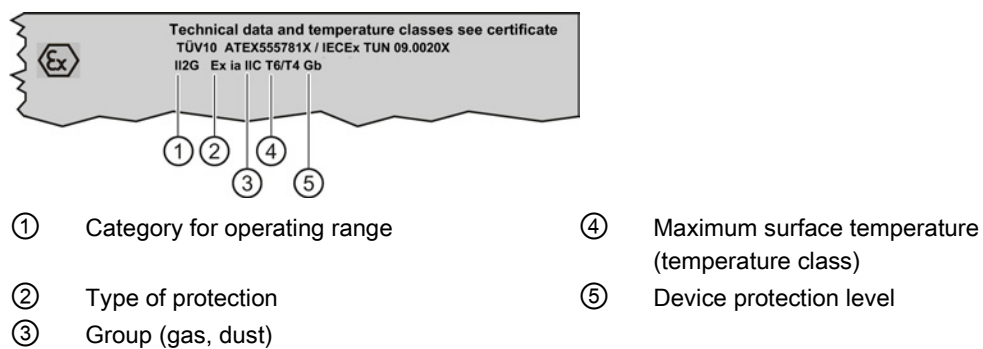

Figure 3-6 Explanation of Ex information

### 3.3 Device components

#### 3.3.1 Overview of device components

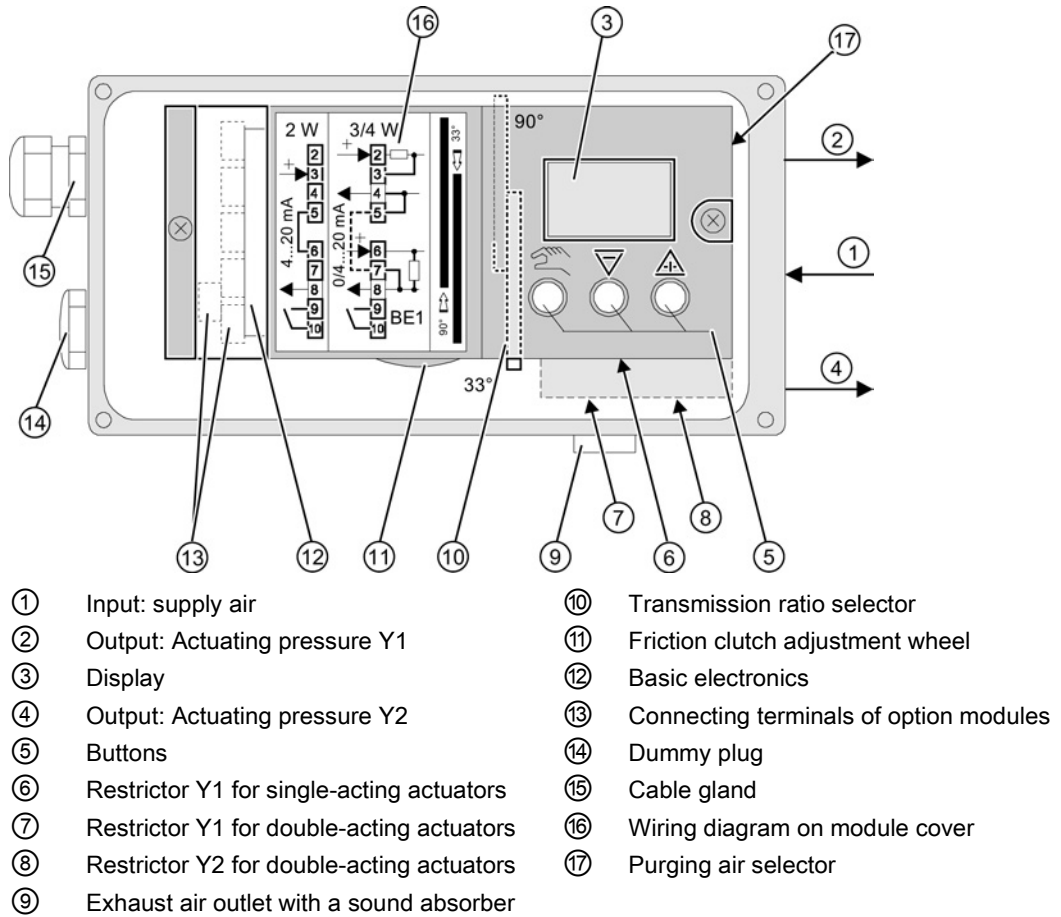

Figure 3-7 View of basic positioner with cover open



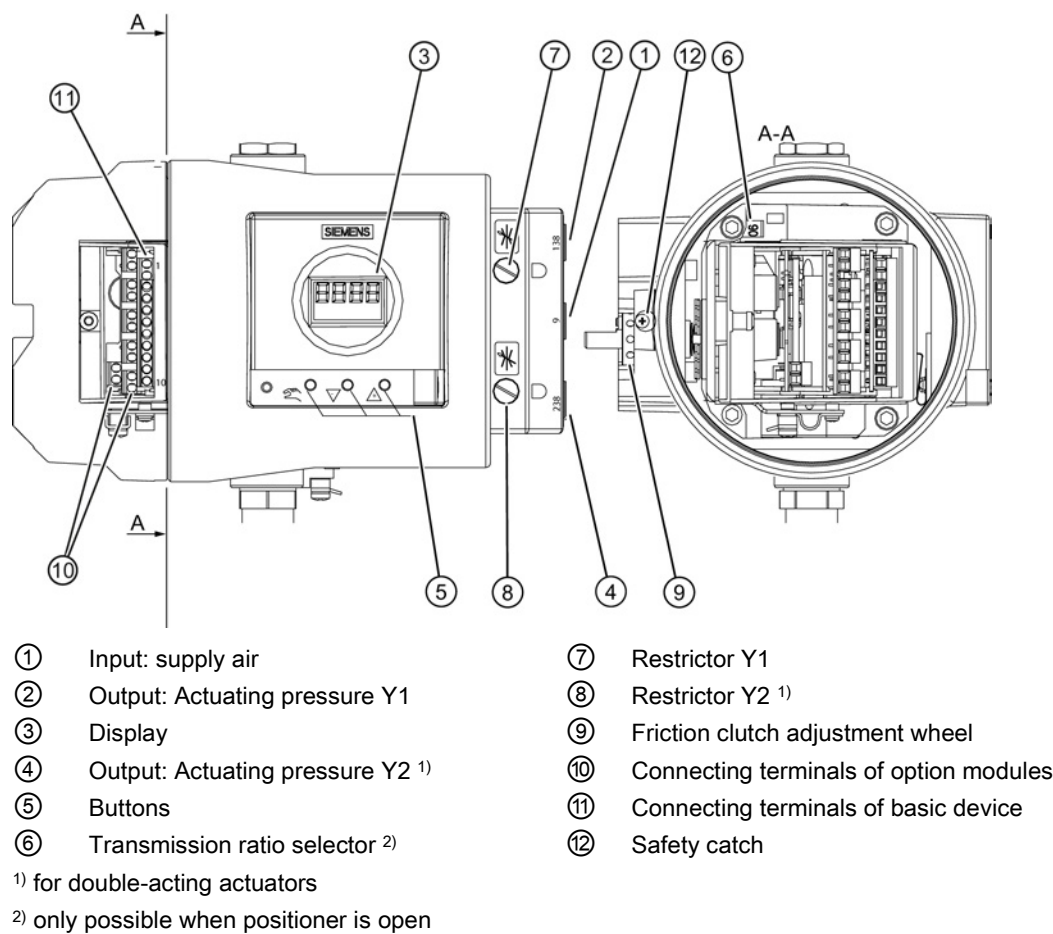

Figure 3-8 View of positioner in flameproof enclosure

### 3.3.2 Basic electronics

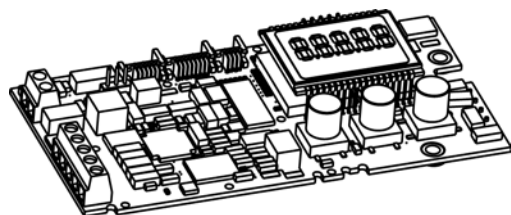

Figure 3-9 Basic electronics

The basic electronics contains:

- CPU
- Memory
- Analog-to-digital converter
- Display

### 3.4 Mode of operation

- Buttons
- Terminal strips to connect the option module to the basic electronics

## 3.4 Mode of operation

### Control loop

The electropneumatic positioner forms a control loop with the pneumatic drive:

- The actual value  $x$  represents the position of the drive spindle for linear actuators or the position of the drive shaft for part-turn actuators.
- The control value  $w$  represents the positioning current of a closed-loop controller or a manual control station from 0/4 to 20 mA.

The lifting or rotary movement of the actuator is transferred to a potentiometer using suitable attachments, positioner axis and a backlash-free, switchable gear drive, and then to the analog input of the microcontroller. The current position can also be forwarded to the positioner using an external sensor. A **Non-Contacting Position Sensor (NCS)** is used to record the lifting or rotation angle directly on the actuator.

The microcontroller:

- Corrects the angle error of the shaft pick-up if necessary.
- Compares the potentiometer voltage as actual value  $x$  with the setpoint  $w$ . The setpoint  $w$  is connected to terminals 6 and 7 by means of PROFIBUS communication.
- Calculates the manipulated variable increments  $\pm\Delta y$ .

The piezo-controlled inlet or exhaust air valve is opened depending on the magnitude and direction of the control deviation ( $x-w$ ). The actuator volume integrates the controller increment for the actuating pressure  $y$  which is proportional to the drive rod or the drive shaft. This controller increment change the actuating pressure until the control deviation becomes zero.

Pneumatic actuators are available in single and double-acting versions. In a single-acting version, only one pressure chamber is ventilated and depressurized. The pressure developed works against a spring. In a double-acting version, two pressure chambers work against each other. Ventilating the volume of one chamber simultaneously depressurizes the volume of the other.

### See also

Block circuit diagram for signal-acting or dual-acting drives (Page 26)

### 3.4.1 Control algorithm

The control algorithm is an adaptive, predictive five-point controller.

In case of large control deviations, the valves are controlled using permanent contact. This takes place in the so-called fast step zone.

In case of medium control deviations, valves are controlled using pulse-length modulated pulses. This takes place in the so-called slow step zone.

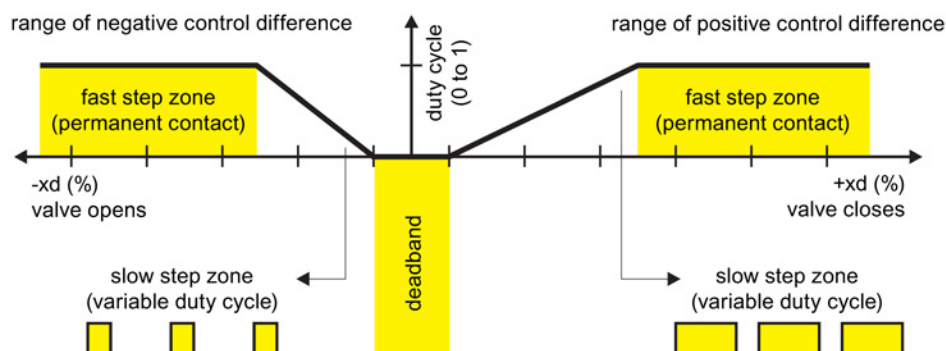

Figure 3-10 Functional principle of five-point controller

Small control deviations do not send control pulses in the zone. This takes place in the so-called adaptive deadband. The deadband adaptation and the continuous adaptation of minimum pulse lengths in the automatic mode ensure the best possible control accuracy with the smallest number of operating cycles. The start parameters are determined during the initialization phase and stored in the non-volatile memory. The most important start parameters are:

- The real actuator travel with mechanical end stops
- Actuating times
- The deadband size

The number of fault messages, changes in direction and the stroke number are continuously determined during operation and saved after every 15 minutes. You can read and document these parameters using communication programs such as PDM and AMS. By comparing the old values with the current ones, you can draw conclusions about the wear and tear of the control valve. You can use the diagnostics function for this.

3.4.2 Block circuit diagram for signal-acting or dual-acting drives

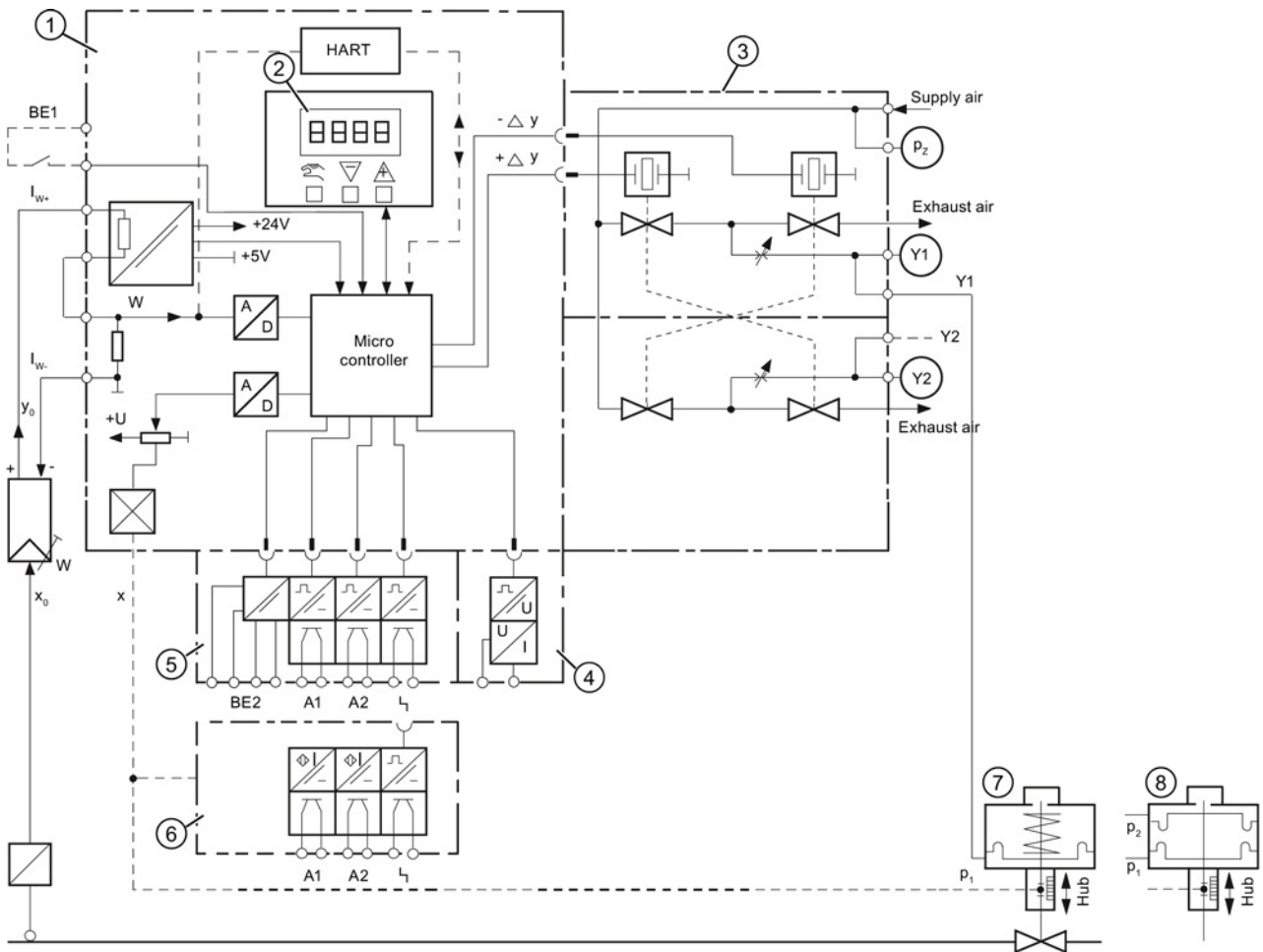

- ① Basic electronics with microcontroller and input circuit
- ② Control pad with display and buttons
- ③ Single-acting (6DR5.1.) or double-acting (6DR5.2.) pneumatic block
- ④ I<sub>y</sub> module for positioner
- ⑤ Alarm module for three alarm outputs and one binary input
- ⑥ SIA module (slot initiator alarm module)
- ⑦ Spring-loaded pneumatic positioning drive (single-acting)
- ⑧ Pneumatic actuator (double-acting)

Figure 3-11 Block circuit diagram for the electropneumatic positioner, functional diagram

**Note**

**Alarm module and SIA module**

Alarm module ⑥ and SIA module ⑦ can only be alternatively used.

### 3.4.3 Mode of operation of the HART function

---

**Note****Priority of operation / failure of power supply**

- Operation at the positioner has priority over specifications from the HART communicator.
  - Failure of the auxiliary power to the positioner also interrupts communications.
- 

**Function**

The positioner is also available with built-in HART functionality. The HART protocol allows you to communicate with your device using a HART communicator, PC, or programming unit. You can do the following with your device:

- Convenient configuration
- Store configurations
- Call up diagnostic data
- Show online measured values

Communication takes place as frequency modulation on the existing signal lines for the control values of 4 to 20 mA.

The positioner is integrated into the following parameter assignment tools:

- HART communicator
- PDM (Process Device Manager)
- AMS (Asset Management System)

*Description*

---

*3.4 Mode of operation*

# Installing/mounting

## 4.1 Basic safety instructions

 <b>WARNING</b>
<b>Unsuitable device for the hazardous area</b>
Danger of explosion.
<ul style="list-style-type: none"><li>• Only use equipment that is approved for use in the intended hazardous area and labelled accordingly.</li></ul>

 <b>WARNING</b>
<b>High operating force with pneumatic drives</b>
Risk of injury when working on control valves due to the high operating force of the pneumatic drive.
<ul style="list-style-type: none"><li>• Please observe the corresponding safety instructions for the pneumatic actuator in use.</li></ul>

 <b>WARNING</b>
<b>Lever for position detection</b>
Danger of crushing and shearing with mounting kits which use a lever for position detection. During commissioning and ongoing operation, severing or squeezing of limbs could occur as a result of the lever. Risk of injury when working on control valves due to the high operating force of the pneumatic drive.
<ul style="list-style-type: none"><li>• Do not reach into the range of motion of the lever following mounting of the positioner and mounting kit.</li></ul>

 <b>WARNING</b>
<b>Impermissible accessories and spare parts</b>
Danger of explosion in areas subject to explosion hazard.
<ul style="list-style-type: none"><li>• Only use original accessories or original spare parts.</li><li>• Observe all relevant installation and safety instructions described in the instructions for the device or enclosed with the accessory or spare part.</li></ul>

 <b>WARNING</b>
<b>It is possible to damage the cover gasket</b> If the cover gasket is not positioned correctly in the groove of the base plate, it could be damaged when the cover is mounted and screwed tight. <ul style="list-style-type: none"><li>• Therefore make sure that the gasket is seated correctly.</li></ul>

 <b>WARNING</b>
<b>Open cable inlet or incorrect cable gland</b> Danger of explosion in hazardous areas. <ul style="list-style-type: none"><li>• Close the cable inlets for the electrical connections. Only use cable glands or plugs which are approved for the relevant type of protection.</li></ul>

See also

Construction (Page 225)

 <b>WARNING</b>
<b>Exceeded maximum ambient or process media temperature</b> Danger of explosion in hazardous areas. Device damage. <ul style="list-style-type: none"><li>• Make sure that the maximum permissible ambient and process media temperatures of the device are not exceeded. Refer to the information in Chapter "Technical data (Page 223)".</li></ul>

 <b>CAUTION</b>
<b>Unsuitable compressed air</b> Device damage. As a general rule, the positioner must only be operated with dry and clean compressed air. <ul style="list-style-type: none"><li>• Use the customary water separators and filters. An additional dryer is required in extreme cases.</li><li>• Use dryers, especially if you operate the positioner at low ambient temperatures.</li></ul>



 **CAUTION**

**Please note the following before working on the control valve and when attaching the positioner**

Danger of injury.

- Prior to working on the control valve, you must move the control valve into a completely pressureless state. Proceed as follows:
  - Depressurize the drive chambers.
  - Switch off the supply air Pz.
  - Lock the valve in its position.
- Make sure that the valve has reached the pressureless state.
- If you interrupt the pneumatic auxiliary power to the positioner, the pressureless position may only be reached after a certain waiting time.
- When mounting, observe the following sequence imperatively to avoid injuries or mechanical damage to the positioner/mounting kit:
  - Mount the positioner mechanically.
  - Connect the electrical auxiliary power supply.
  - Connect the pneumatic auxiliary power supply.
  - Commission the positioner.

 **WARNING**

**Mechanical impact energy**

Protect the 6DR5...0-.G...-.... version of the positioner from mechanical impact energy greater than 1 joule; this ensures adherence to the IP66 degree of protection.

**NOTICE**

**Impact energy and torque**

**For versions 6DR5a.b-.Gc.-....., where a = 0, 2, 5, 6; b = 0, 1; c = G, N, M, P, Q, the following is applicable:**

The device must be protected against power surges of over one joule.

**For versions 6DR5a.b-.Gc.-....., where a = 0, 2, 5, 6; b = 0; c = G, N, M, P, Q, the following is applicable:**

The maximum torque on the thread of the cable gland should not exceed 67 Nm.

### 4.1.1 Proper mounting

<b>NOTICE</b>
<b>Incorrect mounting</b> The device can be damaged, destroyed, or its functionality impaired through improper mounting. <ul style="list-style-type: none"><li>• Before installing ensure there is no visible damage to the device.</li><li>• Make sure that process connectors are clean, and suitable gaskets and glands are used.</li><li>• Mount the device using suitable tools. Refer to the information in Chapter "Technical data (Page 223)", for example installation torques requirements.</li></ul>

 <b>CAUTION</b>
<b>Loss of degree of protection</b> Damage to device if the enclosure is open or not properly closed. The degree of protection specified on the nameplate or in Chapter "Technical data (Page 223)" is no longer guaranteed. <ul style="list-style-type: none"><li>• Make sure that the device is securely closed.</li></ul>

## 4.2 Mounting the linear actuator

### Requirements

For linear actuators, use the "linear actuator" mounting kit 6DR4004-8V or the integrated attachment.

This section describes how to connect the mounting kit to the actuator. You require different installation parts depending on the selected actuator type. All installation parts listed in the following table are included in the product package of the mounting kit. The mounting kit is suitable for a stroke of 3 to 35 mm. For a larger stroke range, you require a lever 6DR4004-8L which is to be ordered separately. Keep the suitable installation parts ready:

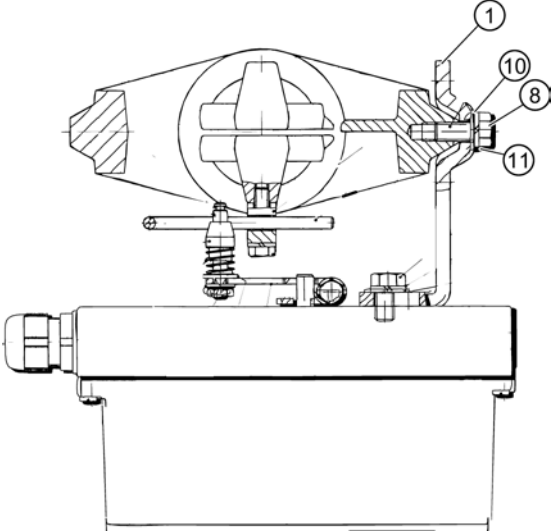
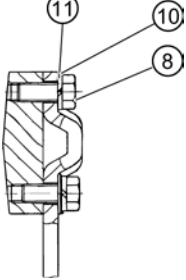
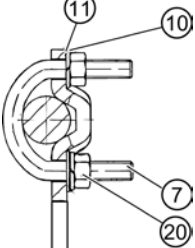
Actuator type	Required installation components	
Actuator with fin	<ul style="list-style-type: none"> <li>• Hexagon bolt ⑧</li> <li>• Washer ⑪</li> <li>• Spring lock washer ⑩</li> </ul>	
Actuator with plane surface	<ul style="list-style-type: none"> <li>• Four hexagon bolts ⑧</li> <li>• Washer ⑪</li> <li>• Spring lock washer ⑩</li> </ul>	
Actuator with columns	<ul style="list-style-type: none"> <li>• Two U-bolts ⑦</li> <li>• Four hexagon nuts ⑳</li> <li>• Washer ⑪</li> <li>• Spring lock washer ⑩</li> </ul>	

**Procedure**

"Linear actuator IEC 60534 (3 mm to 35 mm)" mounting kit 6DR4004-8V and 6DR4004-8L			
Sr. No. *)	Quantity	Name	Note
①	1	NAMUR mounting bracket IEC 60534	Standardized connection point for mount with fin, column or plane surface
②	1	Pick-up bracket	Guide the pulley with the carrier pin and rotates the lever arm.
③	2	Clamping piece	Installs the pick-up bracket on the actuator spindle
④	1	Carrier pin	Installation with pulley ⑤ on lever ⑥
⑤	1	Pulley	Installation with carrier pin ④ on lever ⑥
⑥	1	Lever	For the range of stroke from 3 mm to 35 mm The lever 6DR4004-8L is additionally required for ranges of stroke > 35 mm to 130 mm (not included in the scope of delivery).
⑦	2	U-bolts	Only for actuators with columns
⑧	4	Hexagon bolt	M8x20 DIN 933-A2
⑨	2	Hexagon bolt	M8x16 DIN 933-A2, torque see the chapter "Technical specifications > Construction (Page 225)"
⑩	6	Spring lock washer	A8 - DIN 127-A2
⑪	6	Washer	B8.4 - DIN 125-A2
⑫	2	Washer	B6,4 - DIN 125-A2
⑬	1	Spring	VD-115E 0.70 x 11.3 x 32.7 x 3.5
⑭	1	Spring lock washer	A6 - DIN 137A-A2
⑮	1	Lock washer	3.2 - DIN 6799-A2
⑯	3	Spring lock washer	A6 - DIN 127-A2
⑰	3	Socket cap screw	M6x25 DIN 7984-A2
⑱	1	Hexagon nut	M6 - DIN 934-A4
⑲	1	Square nut	M6 - DIN 557-A4
⑳	4	Hexagon nut	M8 - DIN 934-A4

\*) the serial numbers refer to the images of the description of the installation steps below.

1. Install the clamping pieces ③ on the actuator spindle. Use spring lock washers ⑯ and socket cap screws ⑰ for this purpose.
2. Slide the pick-up bracket ② into the milled recesses of the clamping pieces ③.

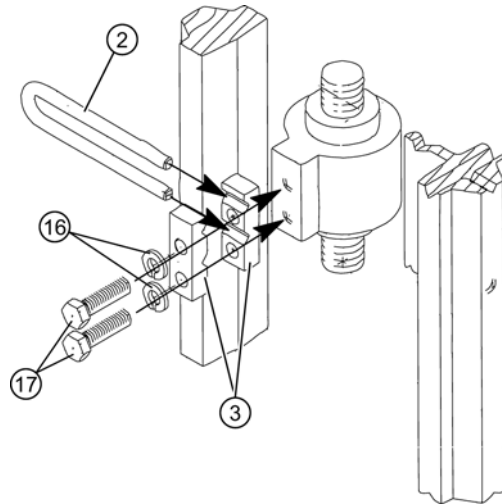

Figure 4-1 Pick-up bracket

3. Set the necessary length.
4. Tighten the screws ⑰ so that you can still shift the pick-up bracket.
5. Fix the pre-installed carrier pin ④ to the lever ⑥. Use the flat washer ⑫, spring lock washer ⑭ and hexagon nut ⑱ for this purpose.

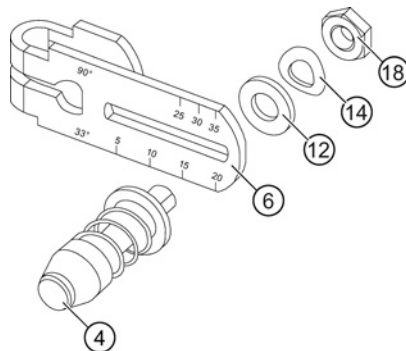

Figure 4-2 Lever with carrier pin

6. Set the stroke value. Use the value specified on the nameplate of the actuator for this purpose. If none of the values on the scale matches the value on the actuator nameplate, select the next higher scaling value. Position the pin center ④ on the matching value of the scale. If you need the value of actuator travel after initialization in mm: ensure that the configured stroke value matches the value of the "3.YWAY" parameter.

4.2 Mounting the linear actuator

7. Install the following components on the lever ⑥: Socket cap screw ⑰, spring lock washer ⑱, flat washer ⑫, square nut ⑲.

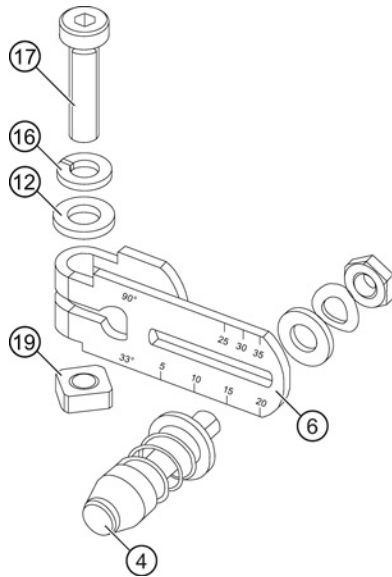

Figure 4-3 Components on the lever

8. Push the pre-installed lever ⑥ up to the end stop on the positioner shaft. Fasten the lever ⑥ using a socket cap screw ⑰.
9. Install the mounting bracket ① at the rear side of the positioner. Use 2 hexagon bolts ⑨, 2 spring lock ⑩ and 2 flat washers ⑪.

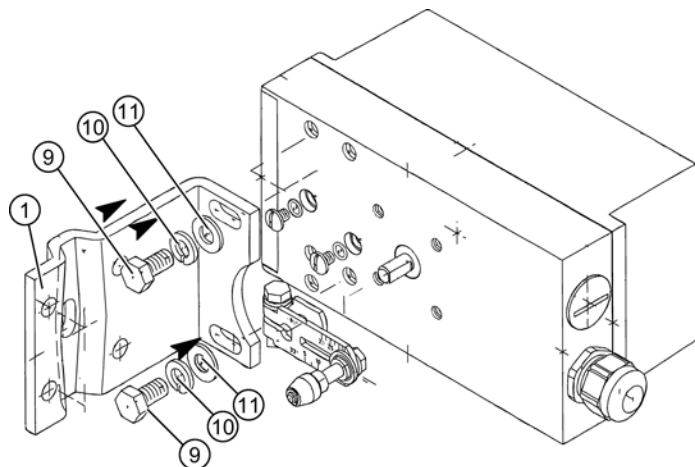

Figure 4-4 Linear actuator in **non-flameproof** enclosure

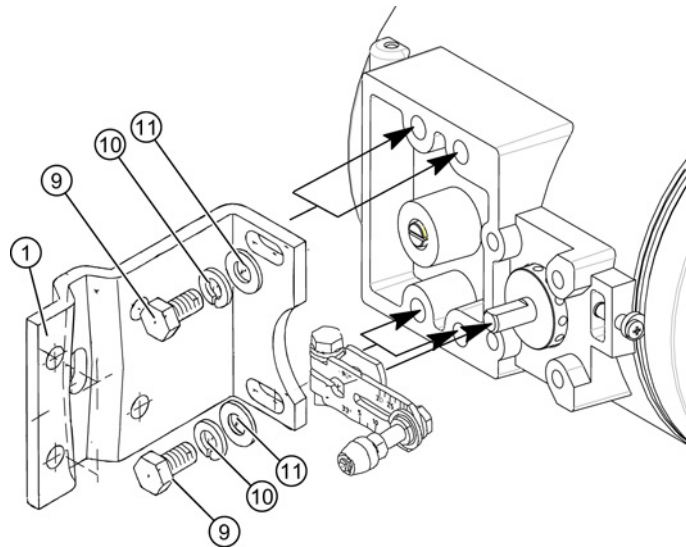

Figure 4-5 Linear actuator in **flameproof** enclosure

10. Select the row of holes. The selection of the row of holes depends on the yoke width of the actuator. Select the row of holes such that the carrier pin ④ meshes with the pick-up bracket ② near the spindle. Ensure that the pick-up bracket ② does not touch the clamping pieces ③.
11. Keep the positioner and the fastening bracket on the actuator. Ensure that the carrier pin ④ is guided inside the pick-up bracket ②.
12. Tighten the pick-up bracket ②.
13. Fasten the positioner on the yoke. Use the installation parts suitable for the corresponding actuator.

---

#### **Note**

##### **Height adjustment of the positioner**

When you fasten the positioner on the yoke, the following applies for its height adjustment:

1. Set the height of the positioner such that the horizontal lever position is near the center of the stroke.
  2. Orient yourself by the lever scale of the actuator.
  3. If symmetrical mounting is not possible, you must always ensure that the horizontal lever position is maintained within the range of stroke.
-

## 4.3 Mounting the part-turn actuator

### Requirements

You require an actuator-specific VDI/VDE 3845 mount to install the positioner on a part-turn actuator. The mount and the bolts are included in the product package of the corresponding actuator. Ensure that the mount has a sheet metal thickness of > 4 mm and reinforcements.

### Procedure

"Part-turn actuator" mounting kit 6DR4004-8D			
Sr. No. *)	Quantity	Name	Note
②	1	Coupling wheel	Installation on positioner axis
③	1	Carrier	Installation on stump of actuator's positioner axis
④	1	Multiple plate	Display of the actuator position, consists of scale ⑤ and pointer mark ⑥
⑤	8	Scale	Different divisions
⑥	1	Pointer mark	Reference arrow for scale
⑭	4	Hexagon bolt	M6x12 DIN 933, torque see the chapter "Technical specifications > Construction (Page 225)"
⑮	4	Lock washer	S6
⑯	1	Socket cap screw	M6x16 DIN 84
⑰	1	Washer	6.4 DIN 125
⑱	1	Hexagon socket-head screw	Pre-installed with coupling wheel
⑲	1	Machinist's wrench	For hexagon socket-head screw ⑱

\*) The serial numbers refer to the images describing the assembly procedure for a part-turn actuator, with and without flameproof enclosure.



1. Rest the actuator-specific VDI/VDE 3845 mount ⑨ on the rear side of the positioner. Tighten the mount using hexagon bolts ⑭ and lock washers ⑮.
2. Stick the pointer mark ⑥ on the mount. Position the pointer mark at the center of the centering hole.

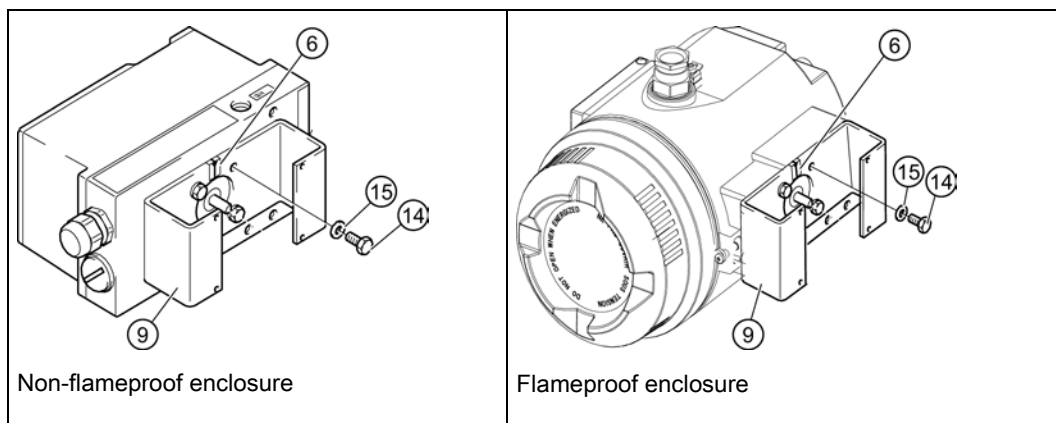

Push the coupling wheel or the stainless steel coupling ② up to the end stop on the positioner shaft. Then retract the coupling wheel or the stainless steel coupling by approximately 1 mm. Tighten the hexagon socket-head screw ⑱ using the machinist's wrench provided. If you are using the stainless steel coupling, omit the next step.

#### Note

##### Coupling wheel

Instead of the plastic coupling wheel ②, it is possible to use a stainless steel coupling (order number TGX: 16300-1556).

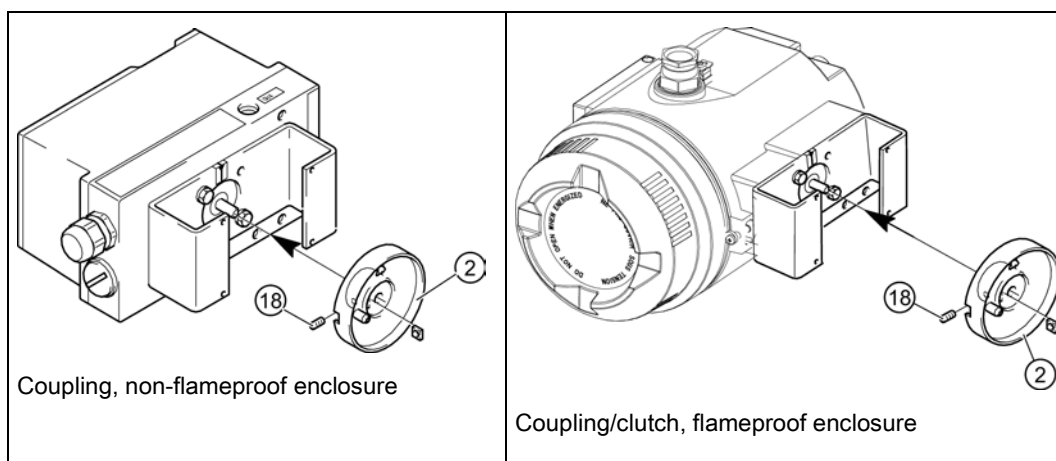

3. Place the carrier ③ on the stump of the actuator's positioner axis. Tighten the carrier using the socket cap screw ⑲ and the washer ⑳.

4.3 Mounting the part-turn actuator

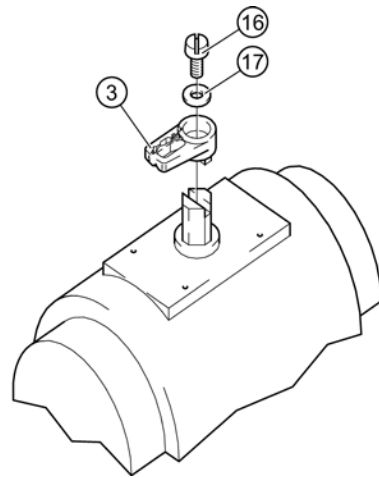
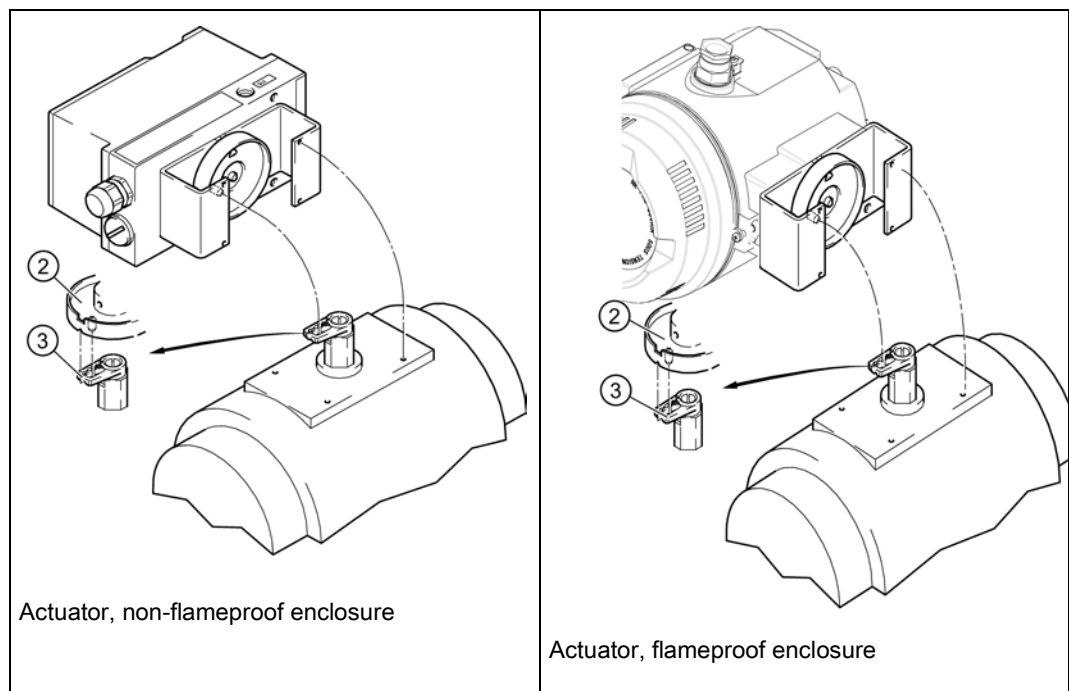

Figure 4-6 Carrier

4. With the coupling wheel: Place the positioner and the mount on the actuator carefully. The pin of the coupling wheel ② must fit in the carrier ③ while doing so.

With the stainless steel coupling: Place the positioner and the mount on the actuator carefully. Place the stainless steel coupling on the stump of the actuator's positioner axis.



5. Align the positioner/mount unit at the center of the actuator.
6. Tighten the positioner/mount unit.
7. Initialize the positioner.

8. After commissioning, drive the positioner to the end position.
9. Stick the scale ⑤ with the direction of rotation or the swivel range on the coupling wheel ②. The stickers with scale are self-adhesive.

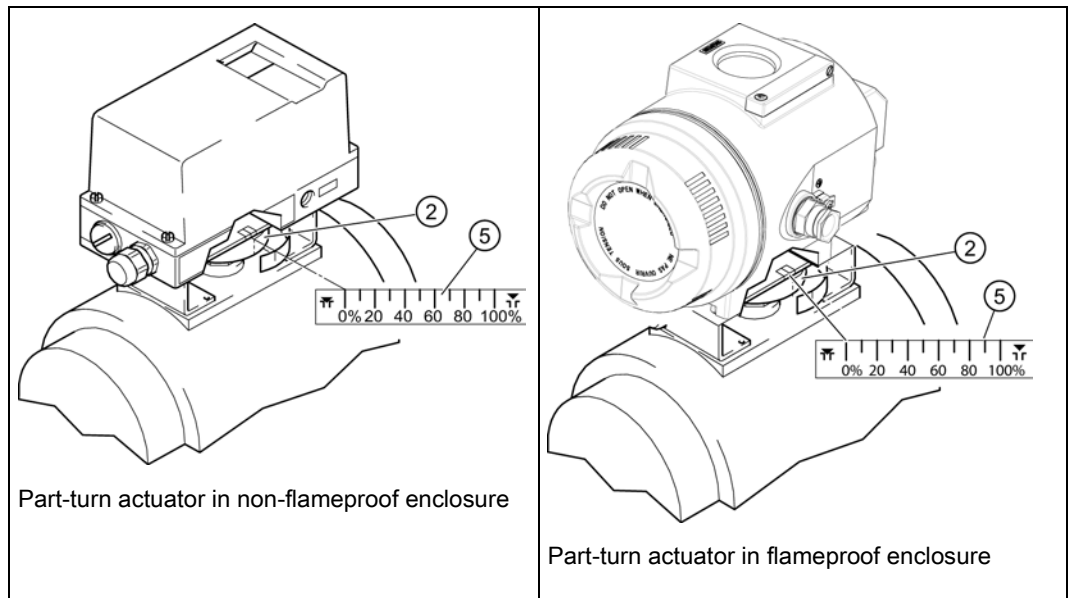

4.3 Mounting the part-turn actuator

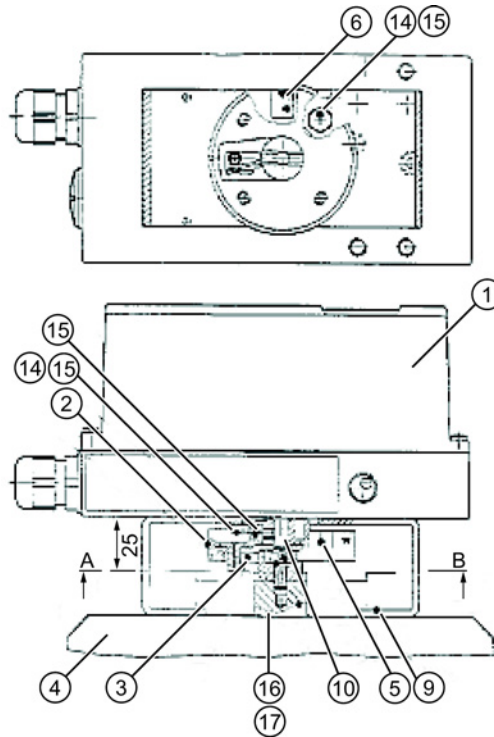

- ① Positioner
- ② Coupling wheel
- ③ Carrier
- ④ Part-turn actuator
- ⑤ Scale
- ⑥ Pointer mark
- ⑨ VDI/VDE 3845 mount
- ⑩ Positioner axis
- ⑭ Hexagonal screw M6x12
- ⑮ Lock washer S6
- ⑯ Cheese head screw M6x12
- ⑰ Washer
- ⑱ Hexagon socket-head screw

Figure 4-7 Attached positioner for part-turn actuators



### Favorable and unfavorable mounting positions

Avoid the unfavorable mounting positions:

- To prevent fluids seeping through during normal operation of the device, e.g. through exhaust air openings.
- Otherwise the display becomes poorly legible.

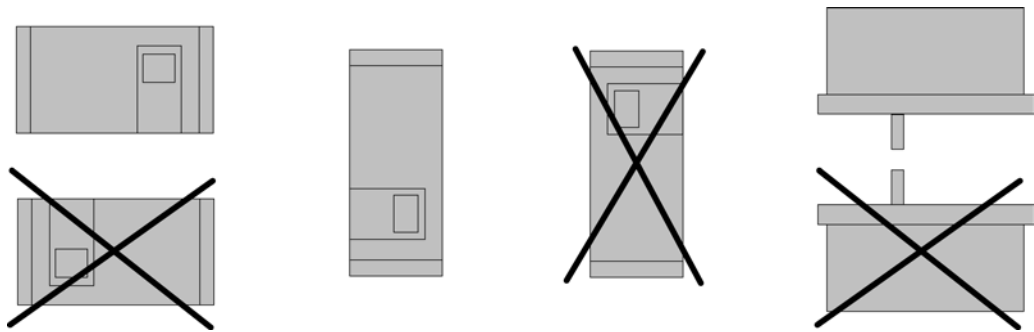

Figure 4-9 Favorable and unfavorable mounting positions

### Additional measures to prevent liquids from seeping through

Take additional measures to prevent liquids from seeping through if the conditions force you to operate the positioner in an unfavorable mounting position.

Additional measures required to prevent liquids from seeping through depend on the selected mounting position. You may also require:

- Gland with sealing ring, e.g. FESTO: CK - 1 / 4-PK-6
- Approximately 20 to 30 cm plastic hose, e.g. FESTO: PUN - 8 x 1.25 SW
- Cable tie; the number and the length depend on the local conditions.

### Procedure

1. Install the casing such that rain water or condensate running along the pipes can be drained before the terminal strip of the positioner.
2. Check the seals of electrical connections for perfect fitting.
3. Check the seal in the enclosure cover for damage and contaminations. Clean and/or replace if required.
4. Install the positioner such that the sintered bronze attenuator at the bottom side of the enclosure points downwards in the vertical mounting position. If this is not possible, replace the attenuator with a suitable gland with a plastic hose.

### Procedure for installing the plastic hose on the gland

1. Unscrew the sintered bronze attenuator from the exhaust air opening at the bottom side of the enclosure.
2. Screw in the aforementioned gland into the exhaust air opening.
3. Install the aforementioned plastic hose into the gland and check whether it fits firmly.

4. Fasten the plastic hose with a cable tie onto the control valve such that the opening points downwards.
5. Ensure that the plastic hose does not have any kinks and the exhaust air flows out without any hindrance.

## 4.5 Positioners subjected to fast acceleration or strong vibration

### 4.5.1 Introduction locking the setting

The electropneumatic positioner has a gear latch for the friction clutch and for the transmission ratio selector.

Strong acceleration forces act on control valves that are subjected to heavy mechanical loads, e.g. breakaway valves, strongly shaking or vibrating valves, as well as in case of "vapor shocks". These forces may be much higher than the specified data. This may cause the friction clutch to move in extreme cases.

The positioner is equipped with a gear latch for the friction clutch to counter these extreme cases. The setting of the transmission ratio selector can also be locked.

The locking procedure is illustrated and described below.

### 4.5.2 Procedure locking the setting

#### Overview diagram

<b>NOTICE</b>
<p><b>Wrong registration of the rotary or part-turn movement</b></p> <p>A different setting of the transmission ratio selector and the gear latch results in a hysteresis in position registration. The hysteresis in position registration can result in unstable control behavior of the higher level control loop.</p> <ul style="list-style-type: none"> <li>• Make sure the transmission ratio selector ⑤ and the gear latch ① are set to the same value, either to 33° or to 90°.</li> </ul>

4.5 Positioners subjected to fast acceleration or strong vibration

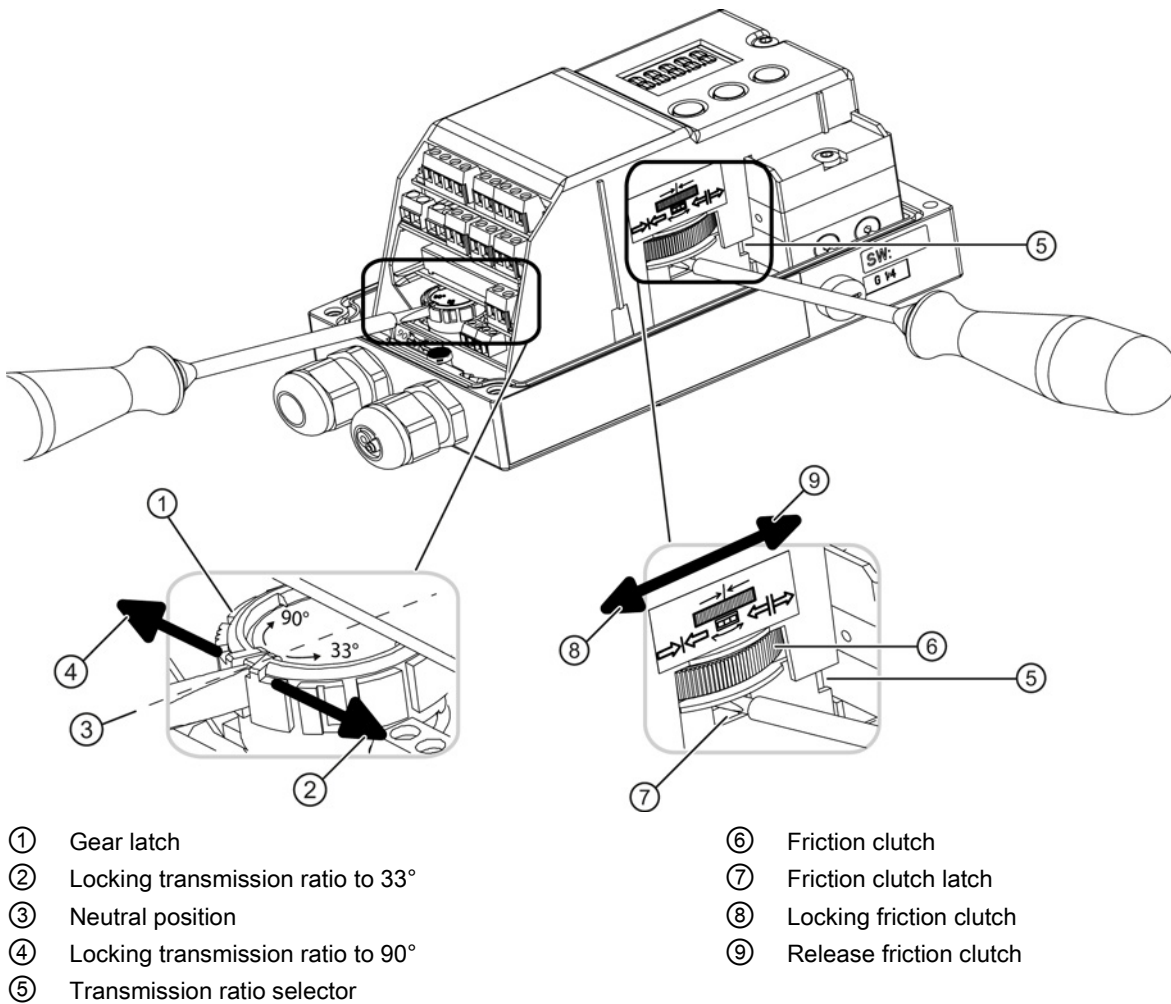

Figure 4-10 Locking friction clutch and transmission ratio

Requirements

- The positioner is mounted.
- You know whether the transmission ratio is to be set to 33° or 90°.
- The positioner has been commissioned successfully, i.e. initialization was completed with "FINISH".



## Procedure

### NOTICE

The following is applicable for the "flameproof enclosure" version:

- A friction clutch is provided on the outside of the positioner axis. Change the work area using this friction clutch, legend number ⑨ in "Figure 3-8 View of positioner in flameproof enclosure (Page 23)".
- Do not open the flameproof enclosure of the positioner in explosion-prone atmospheres.

Fix the setting acquired by initialization as follows:

1. Make sure the gear latch ① is in neutral position ③. The neutral position is between 33° and 90°.
2. Make sure the transmission ratio selector ⑤ is in the correct position.
3. Fix the transmission ratio with the gear latch ①. Turn the gear latch ① with a standard approx. 4 mm wide screwdriver until the gear latch ① locks. Turning right locks the transmission ratio to 33° ②. Turning left locks the transmission ratio to 90° ④. The transmission ratio is locked.

### Note

#### Changing the setting of the transmission ratio selector

The setting of the transmission ratio selector ⑤ can only be changed effectively if the gear latch ① is in the neutral position ③.

4. To fix the friction clutch ⑥ insert a standard approx. 4 mm wide screwdriver in the friction clutch gear latch ⑦.
5. Use the screwdriver to turn the friction clutch gear latch ⑦ anticlockwise until it engages. The friction clutch ⑥ is locked.

## See also

Overview of device components (Page 22)

## 4.6 External position detection

 **WARNING**

**External position detection system**

Versions with flameproof enclosures may not be operated with an external position detection system.

The aforementioned measures are not adequate in some applications. For example, continuous and strong vibrations, high or too low ambient temperatures and nuclear radiation.

The position detection system and the control unit are mounted separately for these applications. A universal component is available for this purpose. It is suitable for part-turn and linear actuators. You will require the following:

- An external position detection system with the order number C73451-A430-D78 comprising a positioner enclosure with an integrated friction clutch, potentiometer as well as different blanking plugs and seals.
- Or a contactless explosion-proof non contacting system (e.g. 6DR4004-6N).
- A positioner
- A three-pole cable to connect components.
- An EMC filter module with the order number C73451-A430-D23 is provided in a set along with cable clamps and M20 cable glands.

The EMC filter module is always used for the control unit whenever an external position detection system is used instead of the internal position sensor. An external position detection system is, for example, a potentiometer with a 10 kΩ resistance or a non contacting system.

## 4.7 Installing option modules

### 4.7.1 General information on installing option modules

 <b>WARNING</b>
<b>Unsuitable device for the hazardous area</b> Danger of explosion. <ul style="list-style-type: none"><li>• Only use equipment that is approved for use in the intended hazardous area and labelled accordingly.</li></ul>

#### 4.7.1.1 Installing optional modules in the standard and intrinsically safe version

The following option modules are available for the positioner in the standard and intrinsically safe version:

- I<sub>y</sub> module
- Alarm module
- SIA module
- Limit contact module
- EMC filter module

Overview diagram: Installing optional modules in the standard and intrinsically safe version

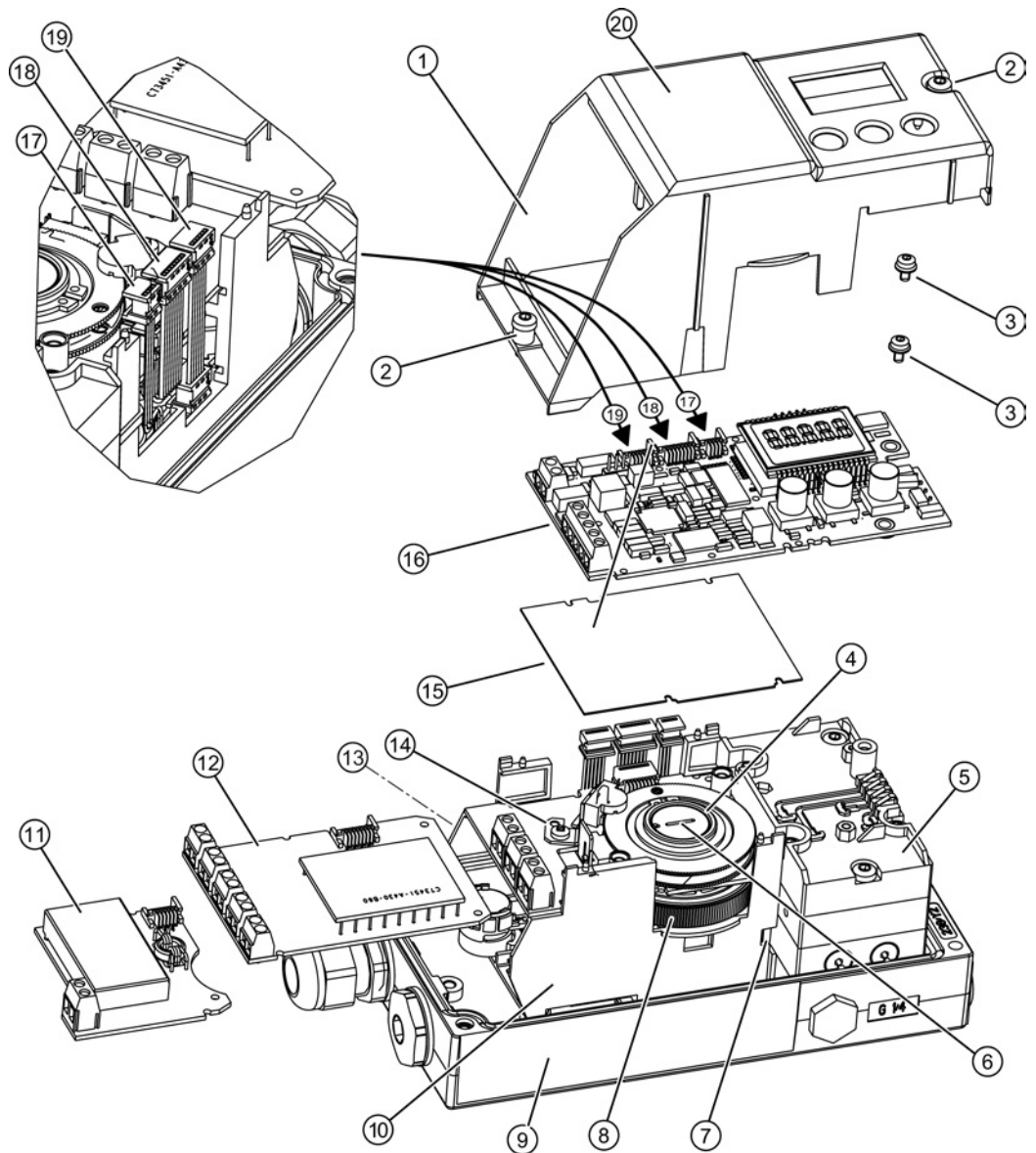

- |   |                                 |   |   |
|---|---------------------------------|---|---|
| ① | Module cover                    | ⑪ | Iy module   |
| ② | Fixing screws module cover      | ⑫ | Alarm module  |
| ③ | Fixing screws basic electronics | ⑬ | Warning label on the side opposite the nameplate                                      |
| ④ | Actuating disk bearings         | ⑭ | SIA module or limit contact module  |
| ⑤ | Pneumatic block                 | ⑮ | Insulating cover  |
| ⑥ | Special screw                   | ⑯ | Basic electronics   |
| ⑦ | Transmission ratio selector     | ⑰ | Ribbon cable/connector for fitted potentiometer or external position detection system |

- |                                    |   |
|------------------------------------|---|
| ⑧ Friction clutch adjustment wheel | ⑱ Ribbon cable/connector for alarm module, SIA module or limit contact module |
| ⑨ Nameplate                        | ⑲ Ribbon cable/connector for I <sub>y</sub> module                            |
| ⑩ Adapter                          | ⑳ Wiring diagram  |

Figure 4-11 Installing the optional modules in the standard and intrinsically safe version

### General procedure for optional modules in the standard and intrinsically safe version

1. Open the positioner. Unscrew the four fixing screws of the enclosure cover.
2. Disconnect the power supply lines or de-energize them.
3. Remove the module cover ①. To do this, unscrew the two screws ②.
4. Install the optional modules as described in the corresponding chapters for the individual optional modules.
5. Now start with the assembly. Install the module cover ①. To this end, turn the screws ② counter clockwise until they noticeably engage in the thread pitch. The module cover protects and locks the optional modules mechanically.

---

#### Note

##### Untimely wear

The module cover is fastened using self-tapping screws. You can prevent the module cover from wearing untimely by adhering to the installation instructions.

---

Carefully tighten both screws ② in a clockwise direction.

6. Continue to assemble the positioner by executing steps 3 to 1 in reverse order.

### See also

- I<sub>y</sub> module (Page 56)
- Alarm unit (Page 57)
- Slot initiator alarm module (Page 59)
- Mechanical limit switch module (Page 62)
- EMC filter module (Page 65)

### 4.7.1.2 Installing the optional modules in the "flameproof enclosure" version

#### Introduction

The following option modules are available for the positioner in the flameproof enclosure:

- I<sub>y</sub> module
- Alarm module
- EMC filter module

 <b>DANGER</b>
<b>Risk of explosion</b>
You must fulfill the following conditions before supplying auxiliary power to the positioner in potentially hazardous areas:
<ul style="list-style-type: none"><li>• The installed electronic unit has been approved.</li><li>• The enclosure of the positioner is closed.</li><li>• The duct openings for electronic connections must be closed. Only use the Ex d certified cable entries or sealing plugs.</li><li>• You must install an ignition trap if you use a "conduit piping system". The maximum distance between the ignition trap and the positioner enclosure is 46 cm or 18".</li></ul>

Overview diagram: Installing the optional modules in the "flameproof enclosure" version

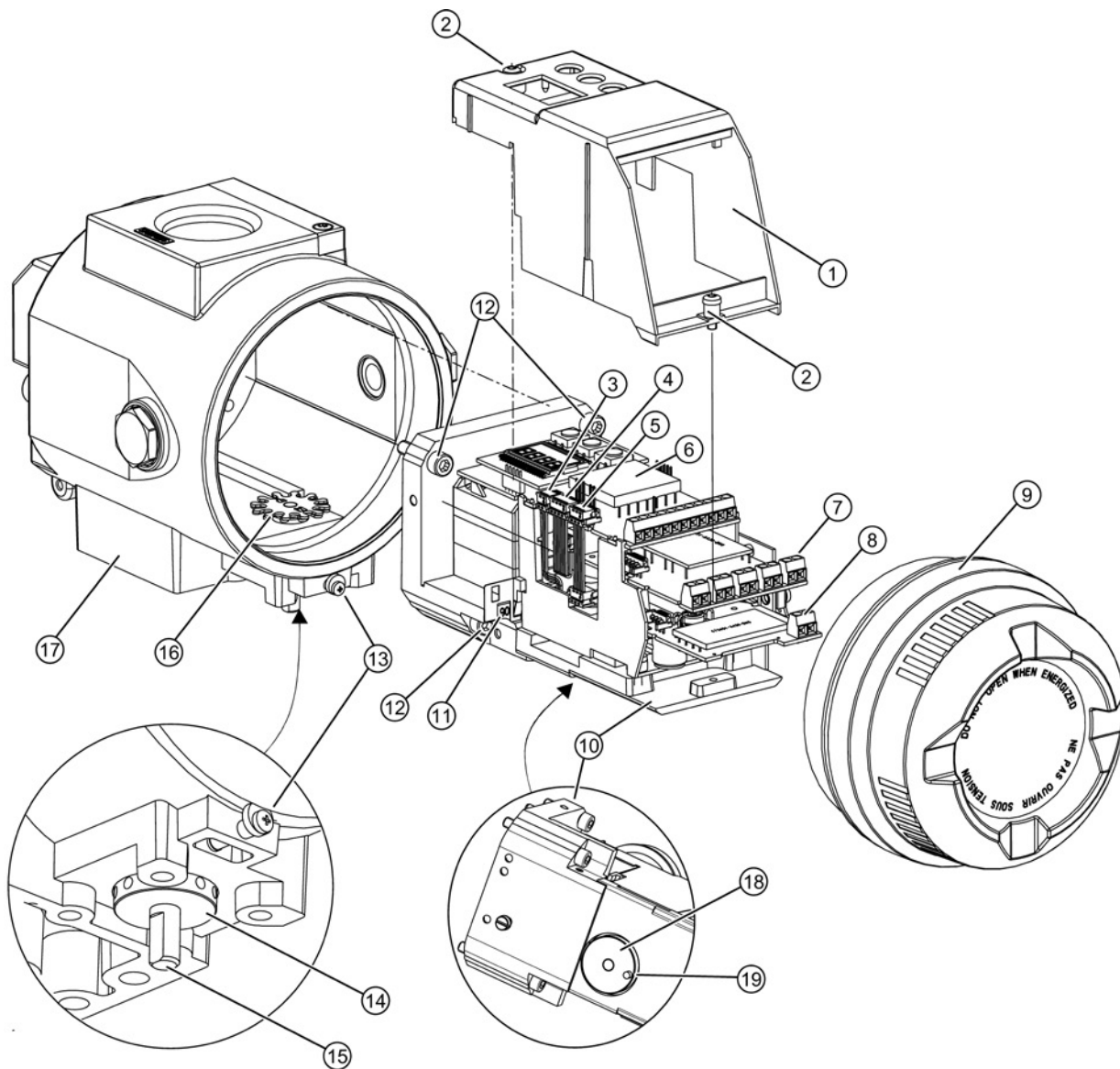

- |   |   |   |                                  |
|---|---|---|----------------------------------|
| ① | Module cover  | ⑪ | Transmission ratio selector      |
| ② | Fixing screws module cover  | ⑫ | Fixing screws adapter            |
| ③ | Ribbon cable/connector for fitted potentiometer or external position detection system | ⑬ | Safety catch                     |
| ④ | Ribbon cable/connector for alarm module   | ⑭ | Friction clutch adjustment wheel |
| ⑤ | Ribbon cable/connector for I <sub>y</sub> module                                      | ⑮ | Feedback shaft                   |
| ⑥ | Basic electronics   | ⑯ | Ring gear                        |
| ⑦ | Alarm module  | ⑰ | Enclosure                        |
| ⑧ | I <sub>y</sub> module   | ⑱ | Feedback lever bracket with pin  |
| ⑨ | Screw cap   |   |                                  |
| ⑩ | Adapter   |   |                                  |

Figure 4-12 Installing the optional modules in the "flameproof enclosure" version

**General procedure for optional modules in the "flameproof enclosure" version**

1. Disconnect the power supply lines or de-energize them.
2. Open the safety catch ⑬.
3. Unscrew the screw cap ⑨.
4. Completely dismount the positioner from the actuator.
5. The positioner comes with a ring gear ⑯ and a pin (feedback lever bracket) ⑲ which interlock and ensure backlash-free position feedback. To ensure backlash-free position feedback make sure to remove the adapter ⑩ carefully. To this end, turn the feedback shaft ⑮ at the positioner until the pin (feedback lever bracket) ⑲ below the adapter shows in the direction of removal. You determine the position of the pin by looking into the enclosure below the adapter. Now, the pin can be easily removed from the ring gear ⑯.

---

**Note**

**Damage to the ring gear**

The ring gear consists of two washers fastened staggered to each other. This offset ensures that path detection is backlash-free.

- Do not change this offset mechanically.

6. Unlatch the four fixing screws ⑫.
7. Completely remove the adapter ⑩ from the enclosure ⑰.

<b>NOTICE</b>
<b>Displaced O-rings</b>
There are several O-rings between adapter ⑩ and enclosure ⑰. These O-rings may come off during removal.
<ul style="list-style-type: none"><li>• Carefully remove the adapter. Make sure the O-rings do not get lost during removal.</li></ul>



8. Remove the module cover ①. Unlatch both screws ② using a screwdriver.
9. Install the optional modules as described in the corresponding chapters for the individual optional modules.
10. Now start with the assembly. Install the module cover ①. To this end, turn the screws ② counter clockwise until they noticeably engage in the thread pitch. The module cover protects and locks the optional modules mechanically.

---

**Note**

**Untimely wear**

The module cover is fastened using self-tapping screws. You can prevent the module cover from wearing untimely by adhering to the installation instructions.

---

Carefully tighten both screws ② in a clockwise direction.



11. Continue to assemble the positioner by performing steps 7 to 5 in reverse order. Check whether the position of the O-rings is correct. Make sure no loose items in the enclosure interfere with the assembly.
12. Now check carefully whether the feedback shaft ⑮ can be smoothly turned by 360°. If you feel resistance, do **not** continue to turn but turn the feedback shaft ⑮ back again to the point of removal, making sure to remember the previously performed steps.
13. Once you have completed all previous steps successfully, continue by performing steps 4 to 1 in reverse order.

### **See also**

- ly module (Page 56)
- Alarm unit (Page 57)
- EMC filter module (Page 65)

## 4.7.2 I<sub>y</sub> module

### Function

- The optional I<sub>y</sub> module indicates the current actuator position as a dual line signal with I<sub>y</sub> = 4 to 20 mA. The I<sub>y</sub> module is potentially separated from the basic device. Thanks to the dynamic control, this module can report the arising operational faults automatically.
- The current actuator position is indicated only after a successful initialization.

### Device features

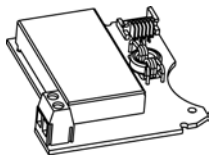

Figure 4-13 I<sub>y</sub> module

The I<sub>y</sub> module is:

- Single channel
- Potentially separated from the basic device.

### Requirements

You are familiar with the general procedure described in the chapter "General information on installing option modules (Page 49)".

### Procedure for installing the I<sub>y</sub> module

1. Slide the I<sub>y</sub> module up to the end stop in the lower stack of the rack.
2. Connect the module to the basic electronics. For this purpose, use the 6-pole flat ribbon cable provided.

### 4.7.3 Alarm unit

#### Function

The alarm module triggers fault messages and alarms using binary outputs. The message function is based on the change in the signal status:

- If the signal status is "HIGH", there is no alarm message and the binary inputs are conductive.
- If the signal status is "LOW", the module reports an alarm by shutting down binary outputs using a high-resistance.
- Thanks to the dynamic control, this module can report the arising operational faults automatically. Set parameters 44 to 51 to activate and configure the output of alarms and fault messages.

Apart from binary outputs, the alarm module has a double-acting binary input BE2. Depending on the selected parameters, it is used to block the actuator or to move it to its end position. Configure the suitable settings on parameter 43.

#### Device features

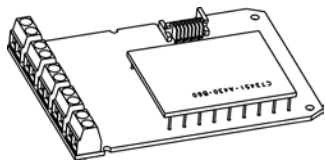

Figure 4-14 Alarm module

The alarm module has the following features:

- Available in two versions.
  - Explosion-proof version for connecting to a switching amplifier in conformity with EN 60947-5-6.
  - Non-explosion-proof version for connecting to power sources having a maximum of 35 V.
- Three binary outputs. Binary inputs are potentially separated from the basic configuration and from each other.
- The binary input has dual functionality. Both inputs are implemented as logical OR combination.
  - Potentially separated for voltage level
  - Not potentially separated for floating contacts

#### Requirements

You are familiar with the general procedure described in the chapter "General information on installing option modules (Page 49)".

**Procedure for installing the alarm module**

1. Slide the alarm module into the rack below the basic electronics . Ensure that you slide it up to the end stop.
2. Connect the module to the basic electronics. For this purpose, use the 8-pole flat ribbon cable provided.

#### 4.7.4 Slot initiator alarm module

##### Function

If the standard controller requires electrically independent limit value messages, the slotted initiator alarm unit with slotted initiators is used instead of the alarm unit.

- A binary output is used to display a collective fault message. Compare with the function of the alarm unit. The floating binary output is implemented as an automatic fault indicating semiconductor output.
- The other two binary outputs are used to signal the two limits L1 and L2 which can be adjusted mechanically using slotted initiators. Both these binary outputs are electrically independent from the remaining electronic unit.

##### Device features

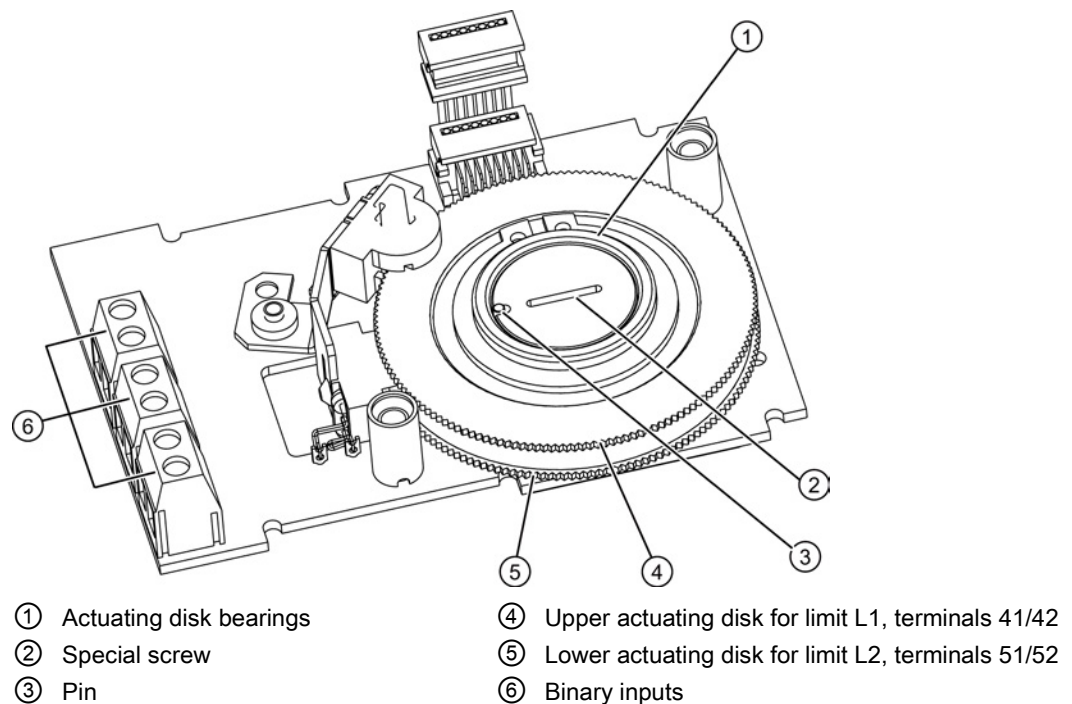

Figure 4-15 SIA module

The slotted initiator alarm unit, short SIA module, consists of three binary outputs ⑥.

##### Requirements

You are familiar with the general procedure described in the chapter "Installing optional modules in the standard and intrinsically safe version (Page 49)".

### Procedure for installing the slot initiator alarm module

1. Disconnect all electrical connections of the basic electronics.
2. Loosen the two fixing screws of the basic electronics.
3. Disengage the basic electronics by carefully bending the four brackets.
4. Insert the SIA module from the top up to the upper printed circuit board guide of the rack.
5. Slide the SIA module in the printed circuit board of the rack approximately 3 mm to the right.
6. Screw in the special screw ② through the SIA module into the positioner shaft. Tighten the special screw ② with a **torque of 2 Nm**.

---

#### Note

##### Pin in the actuating disk bearing

A pin ③ is pressed in the actuating disk bearing ①.

1. Align the pin ③ before it touches the special screw ②.
  2. Rotate the actuating disk bearing ① and the special screw ② simultaneously so that the pin ③ is inserted into the special screw ②.
- 

7. Set the limits L1 and L2 as described in the chapter "Setting the limits of the slotted initiator alarm unit (Page 61)".
8. An insulating cover is provided over the SIA module. Place the insulating cover on one side under the basic electronics seat on the module cover. The recesses of the insulating cover must fit in the corresponding webs of the module cover.
9. Place the insulating cover on the SIA module by bending the module covers carefully.
10. Engage the basic electronics into the four brackets.
11. Fix the basic electronics using both the fixing screws.
12. Reestablish all electrical connections between the basic electronics and the option modules. Connect the basic electronics and the option modules to the ribbon cables provided. Connect the basic electronics and the potentiometer to the potentiometer cable.
13. Using both the screws, fasten the module cover provided. Do **not** use the standard module cover.
14. Select the labels that already exist on the standard version of the module cover from the label set provided. Affix the selected labels on the installed module cover as per the standard version.

#### 4.7.4.1 Setting the limits of the slotted initiator alarm unit

##### **Procedure: Determining the switch status of the slotted initiators**

You will require a suitable display device to determine the switch status. For example, use the initiator tester type 2 / Ex from Pepperl + Fuchs.

1. Connect the display device to the following terminals of the SIA module:
  - 41 and 42
  - 51 and 52
2. Read the switch status of slotted initiators.

##### **Procedure: Setting the L1 and L2 limits**

The serial numbers in the following text refer to the image in the chapter "Slot initiator alarm module (Page 59)". To set the limits proceed as follows with linear actuator:

1. Move the actuator to the first desired mechanical position.
2. Adjust the upper actuating disk ④ manually until the output signal at terminals 41 and 42 changes. Set a high-low or a low-high switchover as follows:
  - Rotate the actuating disc ④ beyond the switching point until you reach the next switching point.
3. Move the actuator to the second desired mechanical position.
4. Adjust the lower actuating disk ⑤ manually until the output signal at terminals 51 and 52 changes. Set a high-low or a low-high switchover as follows:
  - Rotate the actuating disc ⑤ beyond the switching point until you reach the next switching point.

---

##### **Note**

##### **Adjusting the actuating disk**

The actuating disks ④ and ⑤ are relatively difficult to move. This design prevents their unintentional movement during operation. You can achieve an easier and finer adjustment by reducing friction temporarily.

- Move the actuator to and fro while simultaneously holding the actuating disks ④ and ⑤.
-

### 4.7.5 Mechanical limit switch module

#### Function

This module is used to report two limits. These limits are reported using galvanic switching contacts.

#### Device features

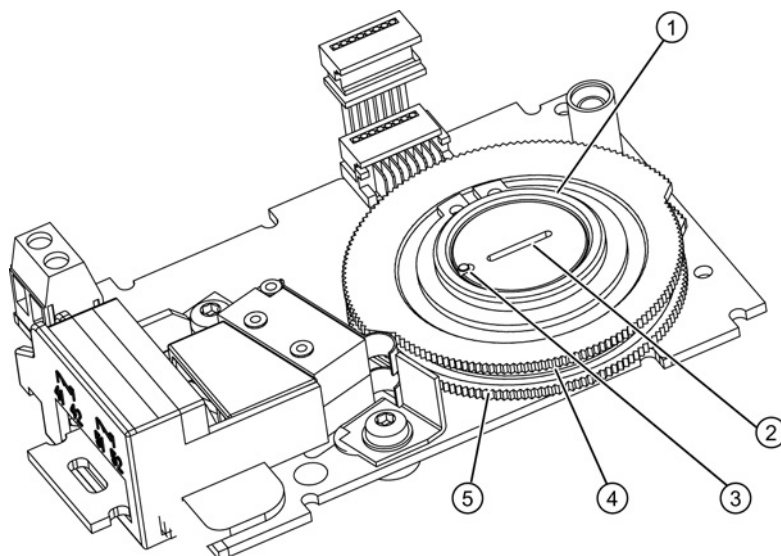

- |                           |  |
|---------------------------|--|
| ① Actuating disk bearings | ④ Upper actuating disk for limit L1, terminals 41/42 |
| ② Special screw           | ⑤ Lower actuating disk for limit L2, terminals 51/52 |
| ③ Pin                     |  |

Figure 4-16 Mechanical limit switch module

The mechanical limit switch module consists of:

- One binary output to display a collective fault message. Compare with the device features of the alarm module.
- Two switches to report two mechanically adjustable limits. Both these switches are electrically independent from the remaining electronic unit.

#### Requirements

You are familiar with the procedure described in the chapter "Installing optional modules in the standard and intrinsically safe version (Page 49)".



### Procedure for installing the mechanical limit switch module

1. Disconnect all electrical connections of the basic electronics.
2. Loosen the two fixing screws of the basic electronics.
3. Disengage the basic electronics by carefully bending the four brackets.
4. Insert the mechanical limit switch module from the top up to the upper printed circuit board guide of the module rack.
5. Slide the mechanical limit switch module in the printed circuit board of the module rack approximately 3 mm towards right.
6. Screw in the special screw ② through the mechanical limit switch module into the positioner shaft. Tighten the special screw ② with a **torque of 2 Nm**.

---

#### **Note**

##### **Pin in the actuating disk bearing**

A pin ③ is pressed in the actuating disk bearing ①.

1. Align the pin ③ before it touches the special screw ②.
2. Rotate the actuating disk bearing ① and the special screw ② simultaneously so that the pins ③ fit into the special screw ②.

- 
7. Set the limits L1 and L2 as described in the chapter "Setting the limits of the mechanical limit switch module (Page 64)".
  8. An insulating cover is provided over the mechanical limit switch module. Place the insulating cover on one side under the basic electronics seat on the walls of the rack. The recesses of the insulating cover must fit in the corresponding webs of the container wall.
  9. Place the insulating cover on the mechanical limit switch module by bending the walls of the rack carefully.
  10. Engage the basic electronics into the four brackets.
  11. Fix the basic electronics using both the fixing screws.
  12. Reestablish all electrical connections between the basic electronics and the option modules. Connect the basic electronics and the option modules to the ribbon cables provided. Connect the basic electronics and the potentiometer to the potentiometer cable.
  13. Using both the screws, fasten the module cover provided. Do not use the standard module cover.
  14. Select the labels that already exist on the standard version of the module cover from the label set provided. Affix the selected labels on the installed module cover as per the standard version.

15. Establish all electrical connections.

---

**Note**

**Protective conductor connector**

A protective conductor connector is not required for safety reasons and therefore is not provided.

---

**See also**

Label set for limit contact module (Page 65)

**4.7.5.1 Setting the limits of the mechanical limit switch module**

**Setting the L1 and L2 limits**

To set the limits proceed as follows. The serial numbers refer to the image in the chapter "Mechanical limit switch module (Page 62)".

1. Move the actuator to the first desired mechanical position.
2. Adjust the upper actuating disk ④ manually until the output signal at terminals 41 and 42 changes. Set a high-low or a low-high switchover as follows:
  - Rotate the actuating disc beyond the switching point until you reach the next switching point.
3. Move the actuator to the second desired mechanical position.
4. Adjust the lower actuating disk ⑤ manually until the output signal at terminals 51 and 52 changes. Set a high-low or a low-high switchover as follows:
  - Rotate the actuating disc beyond the switching point until you reach the next switching point.

---

**Note**

The actuating discs are relatively difficult to move. This design prevents their unintentional movement during operation. You can achieve an easier and finer adjustment by reducing friction temporarily. Move the actuator to and fro while simultaneously holding the actuating discs.

---

### 4.7.5.2 Label set for limit contact module

Fasten the included warning label on the side across from the nameplate. There are different warning labels depending on the enclosure material, as described below.

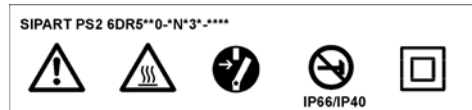

Figure 4-17 Warning label for a device with a Macrolon enclosure



Figure 4-18 Warning label for a device with an aluminum enclosure



Figure 4-19 Warning label for a device with a stainless steel enclosure

### See also

Warning symbols on the device (Page 13)

### 4.7.6 EMC filter module

#### Requirements

- You have an EMC filter module, order number C73451-A430-D23.
- The module cover is removed.
- Any already installed optional module has been removed.

A description of how to remove the module cover and install the optional modules is provided in the chapter "General information on installing option modules (Page 49)"

---

#### Note

##### Different cable glands

A blue and a gray cable gland are provided to distinguish between explosion-proof and not explosion-proof devices.

- Use the blue cable gland for explosion-proof devices in "intrinsically safe" protection type. Use the gray cable gland for all other designs.
-

### Function

You will require the EMC filter module if you use an external position sensor on the positioner, e.g. a potentiometer or a non-contacting position sensor. The EMC filter module forms the interface between external position sensors and the basic electronics of the positioner. This module protects the positioner from electromagnetic effects.

### Device features

- EMC protection
- Connection to basic electronics
- Connecting terminals for an external potentiometer

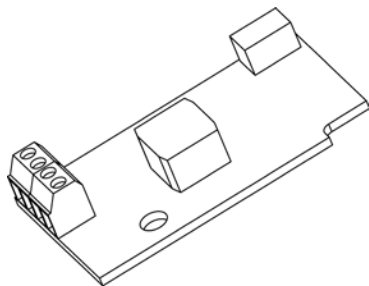
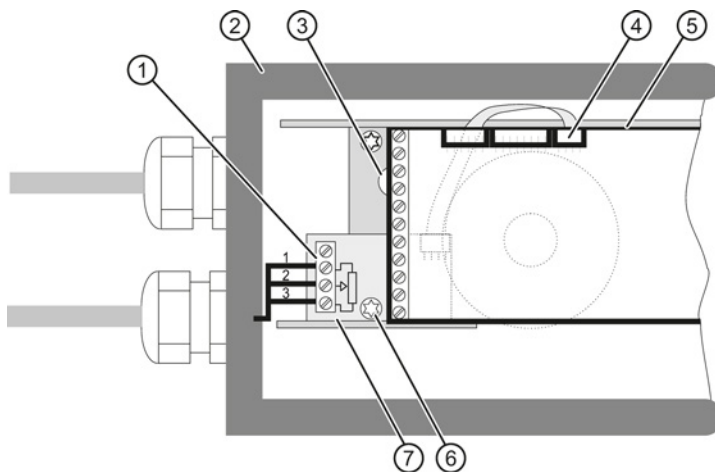

Figure 4-20 EMC filter module

### Procedure for installing the EMC filter module



- |  |                                     |
|--|-------------------------------------|
| ① EMC filter module terminals  | ⑤ Basic electronics                 |
| ② Positioner   | ⑥ Screw                             |
| ③ Yellow wheel for locking the position detection  | ⑦ EMC filter module C73451-A430-D23 |
| ④ Ribbon cable connector of fitted potentiometer, or ribbon cable connector of EMC filter module |                                     |

Figure 4-21 Installation EMC filter module

1. You have performed the steps described in the chapter "General information on installing option modules (Page 49)".
2. Unplug the ribbon cable connector ④ to the fitted potentiometer from the basic electronics ⑤.
3. Remove the basic electronics ⑤ from the positioner. To this end, remove the two screws that fix the basic electronics to the pneumatic block.
4. Loosen the screw ⑥ in the connection area of the positioner.
5. Then secure the loose ribbon cable (B) on the container as shown in the following graphic. To do this, use the cable tie (A) supplied with the EMC filter module C73451-A430-D23

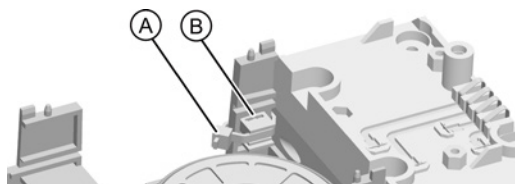

(A) Cable tie

(B) Ribbon cable connector

6. Secure the EMC filter module using the screw ⑥ loosened in the third step.
7. Fit the basic electronics ⑤ back into the positioner.
8. Insert the ribbon cable connector ④ of the EMC filter module onto the positioner basic electronics.
9. In **non-hazardous** environment:
  - Stick the supplied nameplate over the nameplate on the external position detection system.
  - Replace the blue cable gland by the supplied gray cable gland.
10. Fasten the module cover. Make sure that the ribbon cable is not trapped.
11. Proceed with the corresponding steps in the chapter "General information on installing option modules (Page 49)".

Refer to section "Scope of delivery of external position detection system (Page 251)", items "Nameplate for device version **without** explosion protection" and "Gray cable gland".

## See also

Scope of delivery EMC filter module (Page 252)

### 4.7.7 Accessories

#### Pressure gauge block

Pressure gauge blocks that are available as accessories are illustrated below. The gauges display measured values for the actuating pressure and supply air. The image to the left shows the pressure gauge block for single-action actuators. The image to the right shows the pressure gauge block for dual-action actuators.

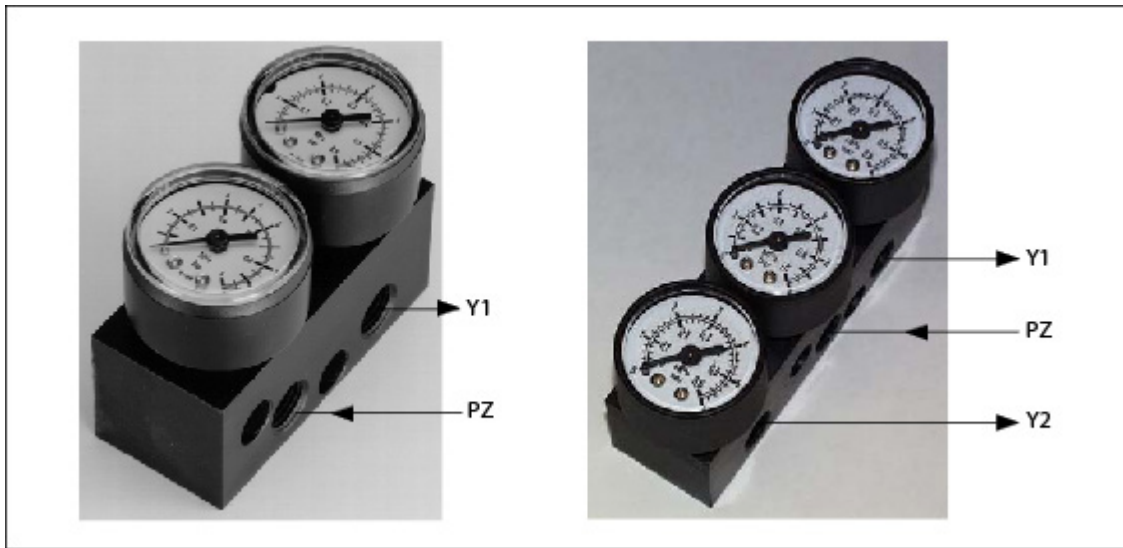

- Y1 Actuating pressure
- Pz supply air
- Y2 Actuating pressure

#### Fixing the pressure gauge block

The pressure gauge block is fixed onto the lateral pneumatic connection of the positioner using the screws provided. Use the provided O-rings as sealing elements.

## Connection

### 5.1 Electric

#### 5.1.1 Basic safety instructions

 <b>WARNING</b>
<b>Improper power supply</b> Danger of explosion in hazardous areas as result of incorrect power supply, e.g. using direct current instead of alternating current. <ul style="list-style-type: none"><li>• Connect the device in accordance with the specified power supply and signal circuits. The relevant specifications can be found in the certificates, in Chapter "Technical data (Page 223)" or on the nameplate.</li></ul>

 <b>WARNING</b>
<b>Unsafe extra-low voltage</b> Danger of explosion in hazardous areas due to voltage flashover. <ul style="list-style-type: none"><li>• Connect the device to an extra-low voltage with safe isolation (SELV).</li></ul>

 <b>WARNING</b>
<b>Connecting device in energized state</b> Danger of explosion in hazardous areas. <ul style="list-style-type: none"><li>• Connect devices in hazardous areas only in a de-energized state.</li></ul> <b>Exceptions:</b> <ul style="list-style-type: none"><li>• Circuits of limited energy may also be connected in the energized state in hazardous areas.</li><li>• Exceptions for type of protection "Non-sparking nA" (Zone 2) are regulated in the relevant certificate</li></ul>

 **WARNING**

**Lack of equipotential bonding**

Danger of explosion through compensating currents or ignition currents through lack of equipotential bonding.

- Ensure that the device is potentially equalized.

**Exception:** It may be permissible to omit connection of the equipotential bonding for devices with type of protection "Intrinsic safety Ex i".

 **WARNING**

**Unprotected cable ends**

Danger of explosion through unprotected cable ends in hazardous areas.

- Protect unused cable ends in accordance with IEC/EN 60079-14.

 **WARNING**

**Improper laying of shielded cables**

Danger of explosion through compensating currents between hazardous area and the non-hazardous area.

- Only ground shielded cables that run into the hazardous area at one end.
- If grounding is required at both ends, use an equipotential bonding conductor.

 **WARNING**

**Unsuitable cables and/or cable glands**

Danger of explosion in hazardous areas.

- Only use suitable cables and cable glands complying with the requirements specified in Chapter "Technical data (Page 223)".
- Tighten the cable glands in accordance with the torques specified in Chapter "Technical data (Page 223)".
- When replacing cable glands use only cable glands of the same type.
- After installation check that the cables are seated firmly.



**⚠ WARNING****Incorrect selection of type of protection**

Danger of explosion in areas subject to explosion hazard.

This device is approved for several types of protection.

1. Decide in favor of one type of protection.
2. Connect the device in accordance with the selected type of protection.
3. In order to avoid incorrect use at a later point, make the types of protection that are not used permanently unrecognizable on the nameplate.

**NOTICE****Condensation in the device**

Damage to device through formation of condensation if the temperature difference between transportation or storage and the mounting location exceeds 20 °C (68°F).

- Before taking the device into operation let the device adapt for several hours in the new environment.

**NOTICE****Ambient temperature too high**

Damage to cable sheath.

- At an ambient temperature  $\geq 60$  °C (140 °F), use heat-resistant cables suitable for an ambient temperature at least 20 °C (68 °F) higher.

**Two-wire mode****NOTICE****Connection of voltage source to current input**

Device damage if a voltage source is connected to the current input  $I_w$  (terminals 6 and 7).

- Never connect the current input  $I_w$  to a voltage source, otherwise the positioner may be destroyed.
- Always use a voltage source with a maximum output current of  $I = 20$  mA.

**Note**

**Improvement of interference immunity**

- Lay signal cables separate from cables with voltages > 60 V.
  - Use cables with twisted wires.
  - Avoid getting too close to large electrical process cells.
  - Use shielded cables to guarantee the full specification according to HART.
  - Take account of the conditions specified in the technical data for HART communication.
- 

**Electromagnetic compatibility**

The Macrolon enclosure is metalized from inside to increase the electromagnetic compatibility (EMC) with respect to high-frequency radiation. The shield is connected to the threaded bush shown in the following picture such that it is electrically conductive.

Note that this protection is effective only if you connect at least one of these bushes to the earthed control valves through electrically conductive (bare) attachments.

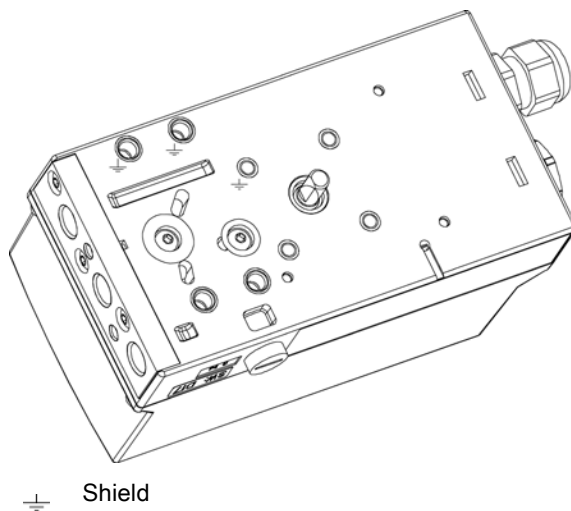

Figure 5-1 Base plate

### 5.1.1.1 Standard cable gland/torque

---

**Note****Standard cable gland/torque**

Device damage.

- Owing the reasons pertaining to tightness (IP enclosure rating) and the required tensile strength, only use the cables having a diameter  $\geq 8$  mm for standard M20x1.5 cable gland, or use a suitable seal insert in case of smaller diameters.
  - In the NPT version, the positioner is delivered with a coupling. When inserting a counter piece in the coupling, ensure that the maximum permissible torque of 10 Nm is not exceeded.
- 

### 5.1.2 Electrical connections

Connecting terminals of the basic device, the I<sub>y</sub> module, and the alarm module are provided at the left front edges, and are arranged in a staircase-shape.

The module cover protects components from being pulled out and prevents an incorrect assembly.

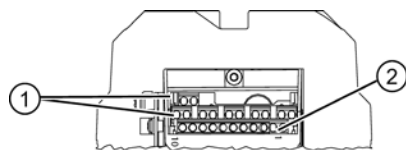

- ① Connecting terminals of option modules
- ② Connecting terminals of basic device

Figure 5-2 Connecting terminals of the flameproof enclosure

5.1.3 Device without Ex protection/Device with Ex d type of protection

5.1.3.1 Basic device without Ex protection / in flameproof enclosure "Ex d"

Connection diagram for order numbers 6DR50..-0N...; 6DR50.5-0E...; 6DR51..-0N...; 6DR51.5-0E...

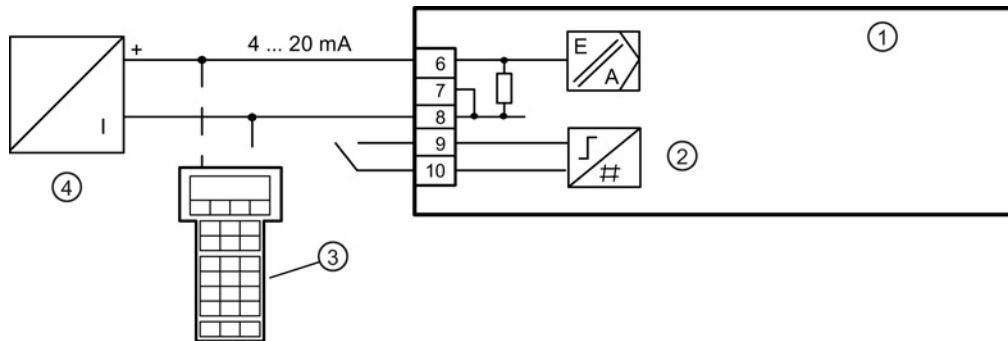

- ① Basic electronics
- ② Binary input 1
- ③ HART communicator for 6DR51..-0N... and 6DR51.5-0E... only
- ④ Signal source

Figure 5-3 Device version 2-wire (without Ex/with Ex d)

Connection diagram for order numbers 6DR52..-0N...; 6DR52.5-0E...; 6DR53..-0N...; 6DR53.5-0E...

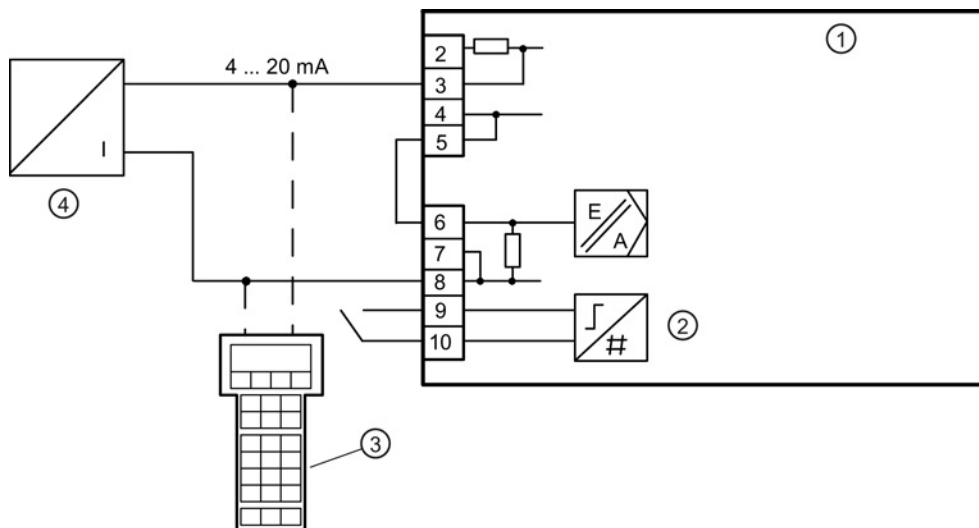

- ① Basic electronics
- ② Binary input 1
- ③ HART communicator for 6DR52..-0N... and 6DR52.5-0E... only
- ④ Signal source

Figure 5-4 Device version 2-/3-/4-wire, with connection type 2-wire (without Ex/with Ex d)

Connection diagram for order numbers 6DR52..-0N...; 6DR52.5-0E...; 6DR53..-0N...; 6DR53.5-0E...

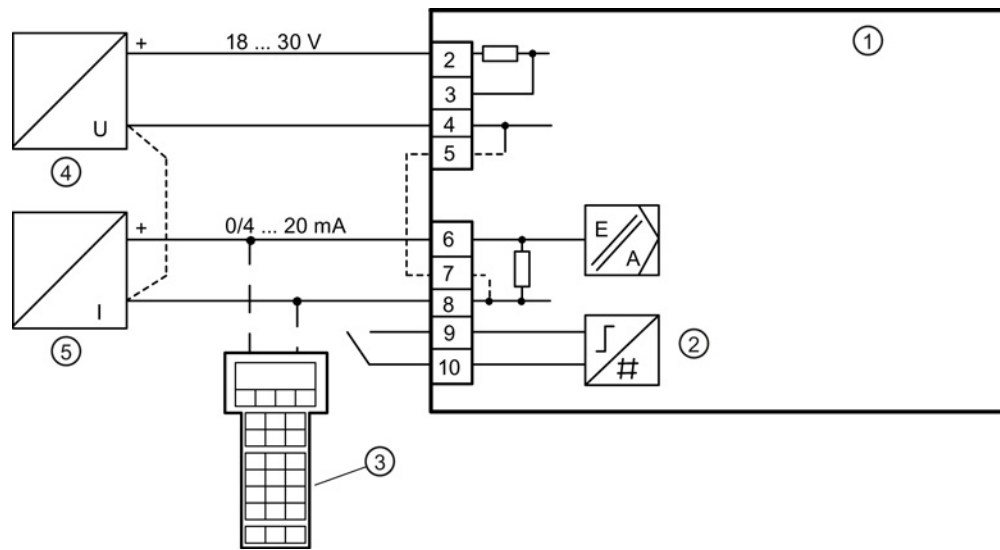

- ① Basic electronics
- ② Binary input 1
- ③ HART communicator for 6DR52..-0N... and 6DR52.5-0E... only
- ④ Power source
- ⑤ Signal source

---- Dotted connection lines: only for three-wire connection

Figure 5-5 Device version 2-/3-/4-wire, with connection type 3-/4-wire (without Ex/with Ex d)

5.1.3.2 Split range without Ex protection / in flameproof enclosure "Ex d"

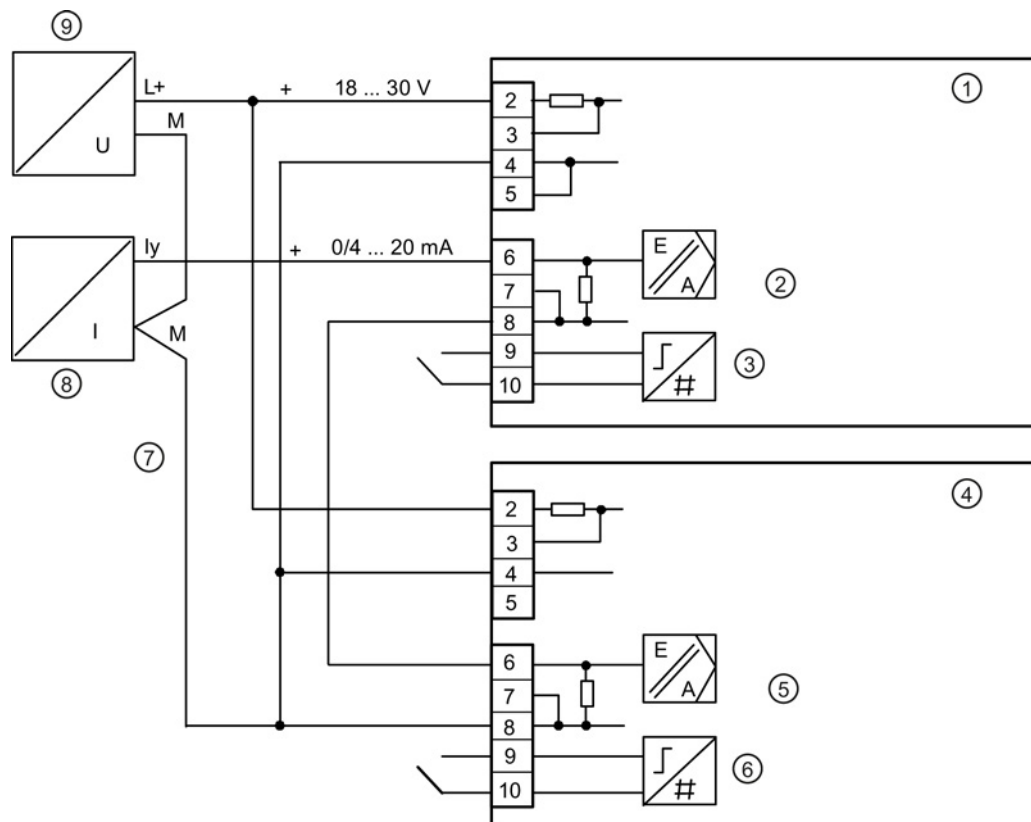

- ① Device 1 - positioner: 6DR52.5; 6DR53.5
- ② Actuating range 1
- ③ Binary input 1
- ④ Device 2 - positioner: 6DR52.5; 6DR53.5
- ⑤ Actuating range 2
- ⑥ Binary input 2
- ⑦ Total actuating range Iy
- ⑧ Signal source
- ⑨ Power source

Figure 5-6 Series connection of 2 positioners, e.g. split range without Ex

### 5.1.3.3 Option modules without Ex protection / in flameproof enclosure "Ex d"

#### Which option module is fitted in which positioner?

The order number of the positioner is present on its nameplate. This coded order number indicates which option module is already installed in your device. The following table lists the assignment between positioner and installed option module.

Table 5- 1 List of option modules fitted in positioners **without explosion protection**

Positioner order number	Contains the following installed option module	Order number for installed option module
6DR5...-0N.1.-0.A.	Alarm module	6DR4004-8A
6DR5...-0N.2.-0.A.	SIA module	6DR4004-8G
6DR5...-0N.3.-0.A.	Mechanical limit switch module	6DR4004-8K
6DR5...-0N..1-0.A.	I <sub>y</sub> module	6DR4004-8J
6DR5...-0N..2-0.A.	EMC filter module	C73453-A430-D23
6DR5...-0N..3-0.A.	I <sub>y</sub> module	6DR4004-8J
	EMC filter module	C73453-A430-D23

Table 5- 2 List of option modules fitted in positioners in **flameproof enclosure "Ex d"**

Positioner	Contains the following installed option module	Order number for installed option module
6DR5..5-0E.1.-0.A.	Alarm module	6DR4004-8A
6DR5..5-0E..1-0.A.	I <sub>y</sub> module	6DR4004-8J

The captions of the following connection graphics for the option modules are made up of the name and order number of the option module.

Alarm module, without Ex protection / in flameproof enclosure "Ex d"

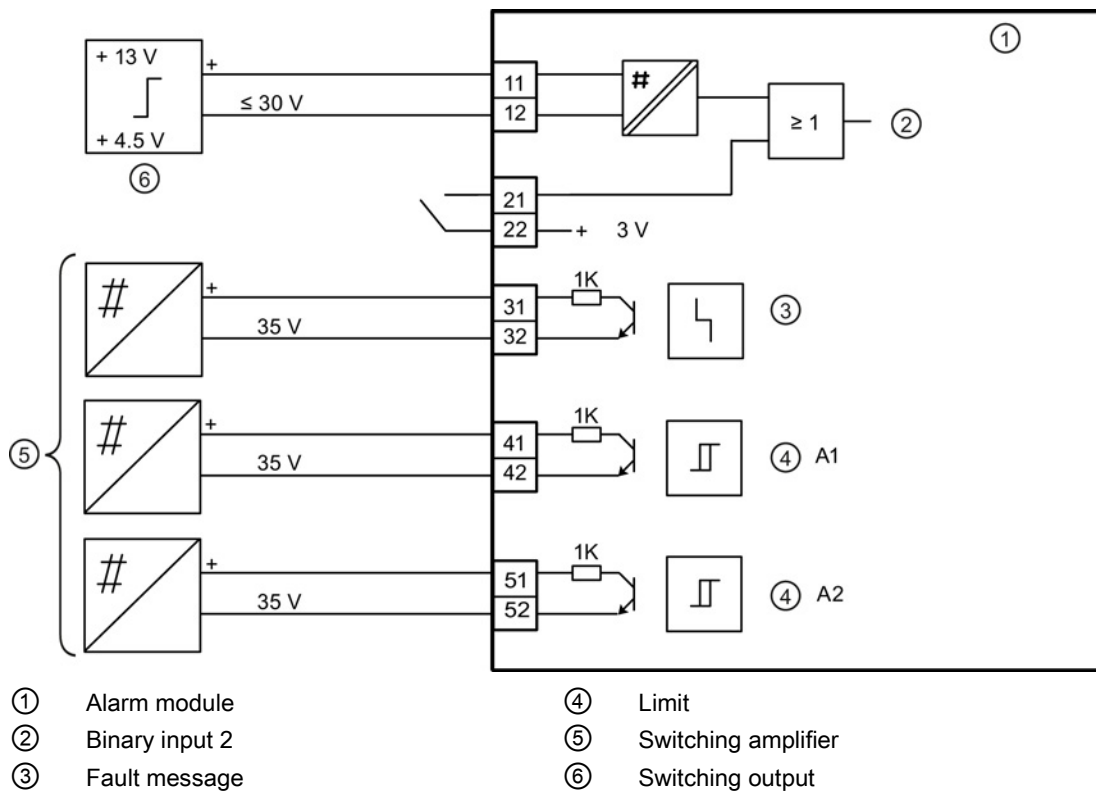

Figure 5-7 Alarm module 6DR4004-8A (without Ex/with Ex d)

Iy module, without Ex protection / in flameproof enclosure "Ex d"

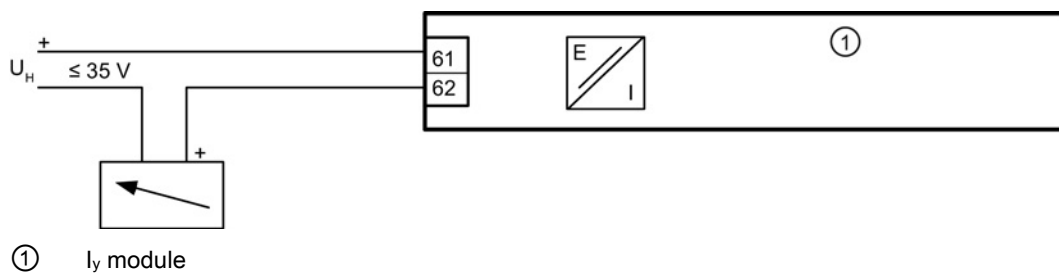

Figure 5-8 Iy module 6DR4004-8J, (without Ex/with Ex d)



SIA module, without Ex protection

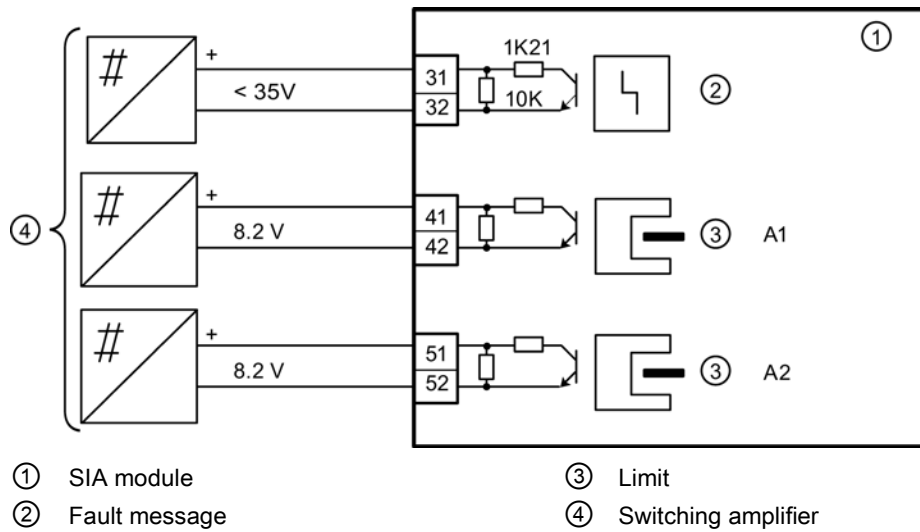

Figure 5-9 SIA module 6DR4004-8G (without Ex)

Limit contact module, without Ex protection

**! DANGER**

**Low-voltage supply**

When you supply the module in the non-intrinsically safe version with low voltage, you must be sure to observe the following safety rules before starting work on the device:

1. Isolate the device from power. Use a circuit breaker positioned near the device to do this.
2. Make sure that the device cannot be switched back on inadvertently.
3. Make sure the device is truly isolated from power.

---

**Note**

**Maximal values for terminals 41/42 and 51/52**

The following maximum values concern only terminals 41, 42, 51, and 52:

- Maximum voltage:
  - Not Ex: AC 250 V or DC 24 V
  - Ex: 30 V DC
- Maximum current:
  - Not Ex: 4 A AC/DC
  - Ex: 100 mA DC
- Maximum performance:
  - Ex: 750 mW

No safe separation between the terminals can be guaranteed.

---

---

**Note**

**To observe before connecting**

Before you connect the mechanical limit switch module, observe the following conditions:

- Isolate all wires from power and make sure the device is truly isolated from power.
  - Construct the cross-sectional area of the connection cables in such a way that it is appropriate for the permitted current load.
- 

---

**Note**

**Preparing the cables or stranded wires**

1. Insulate the cables in such a way that the insulation is flush with the terminal when plugging in the wires.
  2. Fit ferrules to the ends of stranded wires.
-

Connecting

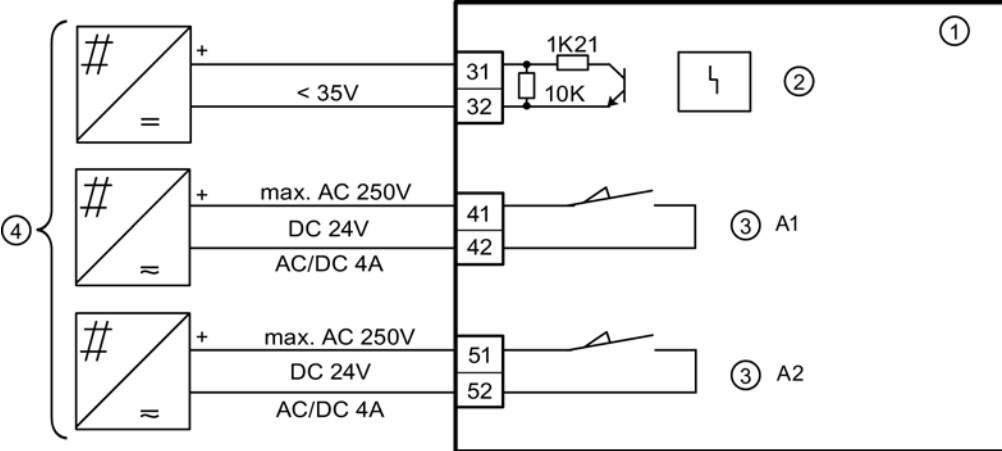

- ① Mechanical limit switch module
- ② Fault message
- ③ Limit
- ④ Switching amplifier

Figure 5-10 Mechanical limit switch module 6DR4004-8K (without Ex)

Procedure

1. Loosen the screw ① on the transparent cover ②.
2. Pull the transparent cover ② up to the front end stop.
3. Tighten every cable in the corresponding terminal.
4. Slide the transparent cover ② up to the end stop of the basic electronics.

5. Tighten the screw ① on the transparent cover ②.
6. Connect the cables of each switch to the lug of the printed circuit board in pairs. Use the provided cable ties ③ for this purpose.

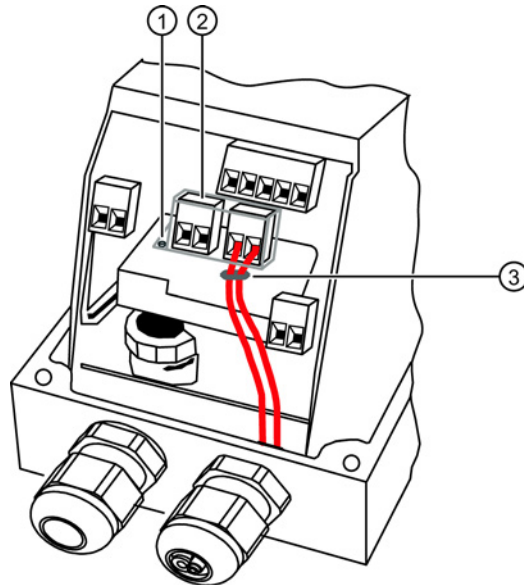

- ① Screw
- ② Cover
- ③ Cable tie

Figure 5-11 Connecting the cables

#### 5.1.4 Device with Ex i/Ex n/Ex t type of protection

<b>⚠ WARNING</b>
<b>With intrinsically device version (Ex i)</b>
Risk of explosion in hazardous areas.
For intrinsically safe device versions only the certified circuits may be connected as auxiliary power supply, control and signal circuits.
<ul style="list-style-type: none"><li>• Make sure that the power source of the used circuits is marked as intrinsically safe.</li></ul>

5.1.4.1 Basic device Ex i/Ex n/Ex t

Connection diagram for order numbers 6DR50..-0E/D/F/G/K...; 6DR51..-0E/D/F/G/K...

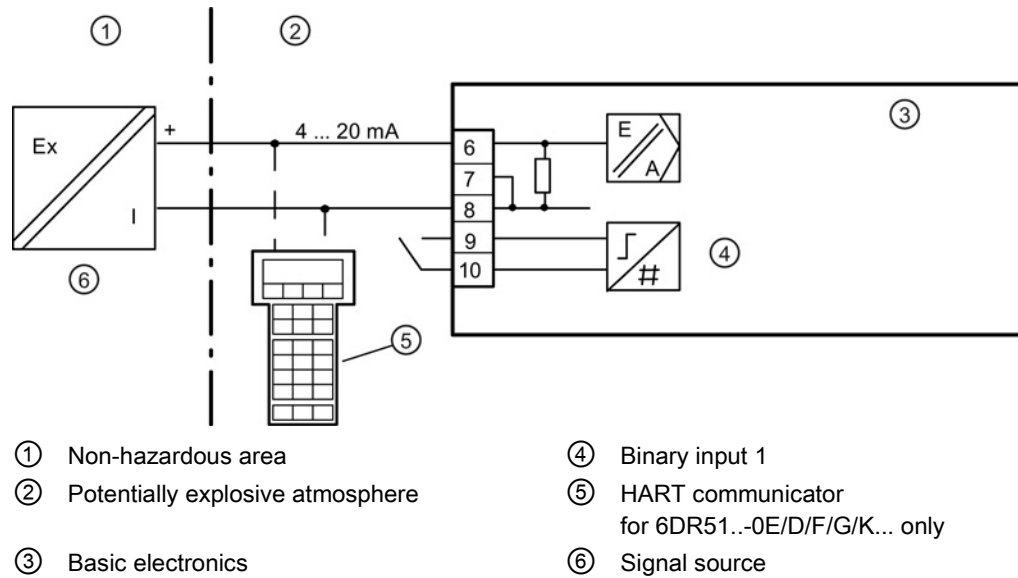

Figure 5-12 2-wire device version (Ex i/Ex n/Ex t)

Connection diagram for order numbers 6DR52..-0E/D/F/G/K...; 6DR53..-0E/D/F/G/K...

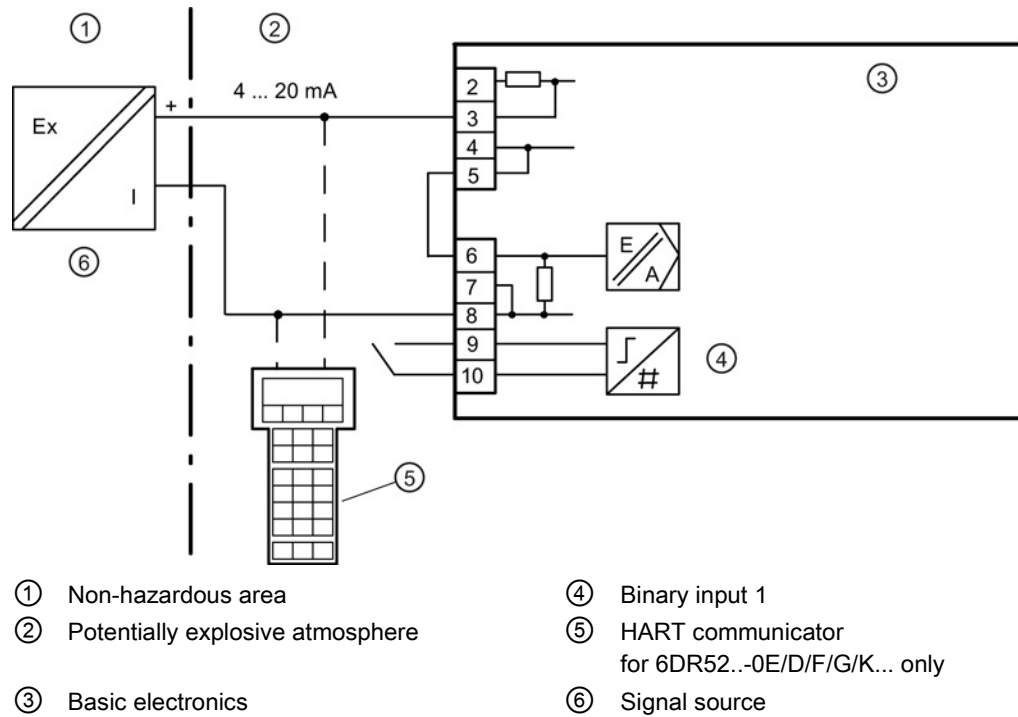
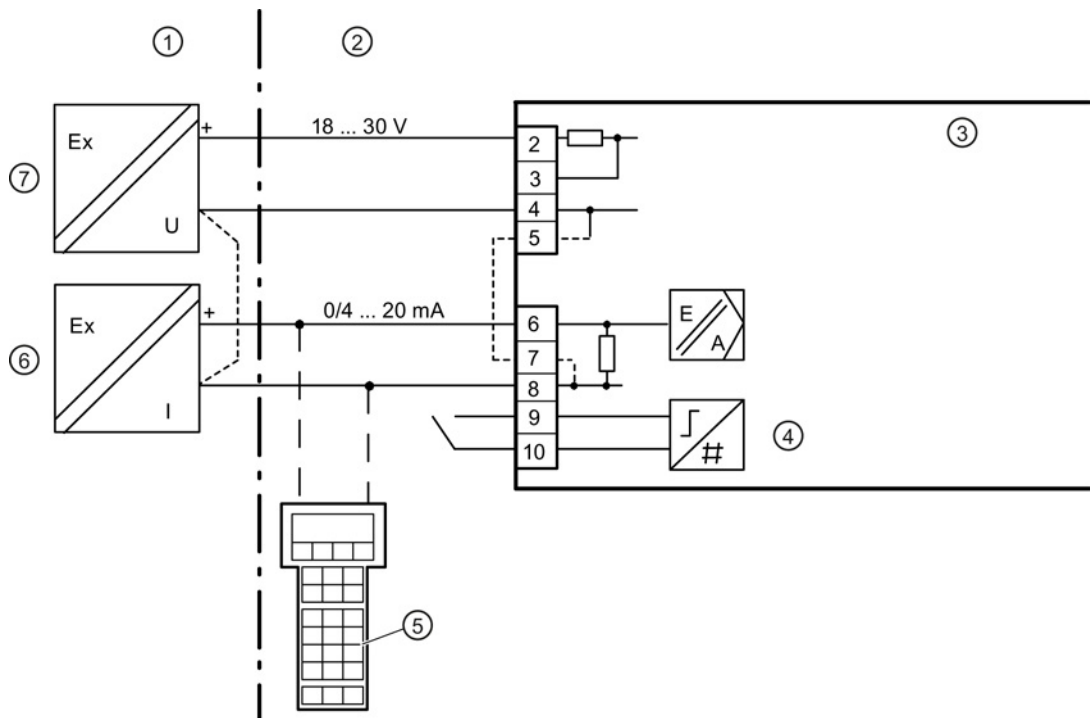

Figure 5-13 2-/3-/4-wire device version, with 2-wire connection type (Ex i/Ex n/Ex t)

Connection diagram for order numbers 6DR52...-0E/D/F/G/K...; 6DR53...-0E/D/F/G/K...



- ① Non-hazardous area
  - ② Potentially explosive atmosphere
  - ③ Basic electronics
  - ④ Binary input 1
  - ⑤ HART communicator for 6DR52...-0E/D/F/G/K... only
  - ⑥ Signal source
  - ⑦ Power source
- Dotted connection lines: only for three-wire connection

Figure 5-14 2-/3-/4-wire device version, with 3-/4-wire connection type (Ex i/Ex n/Ex t)

5.1.4.2 Split range Ex i/Ex n/Ex t

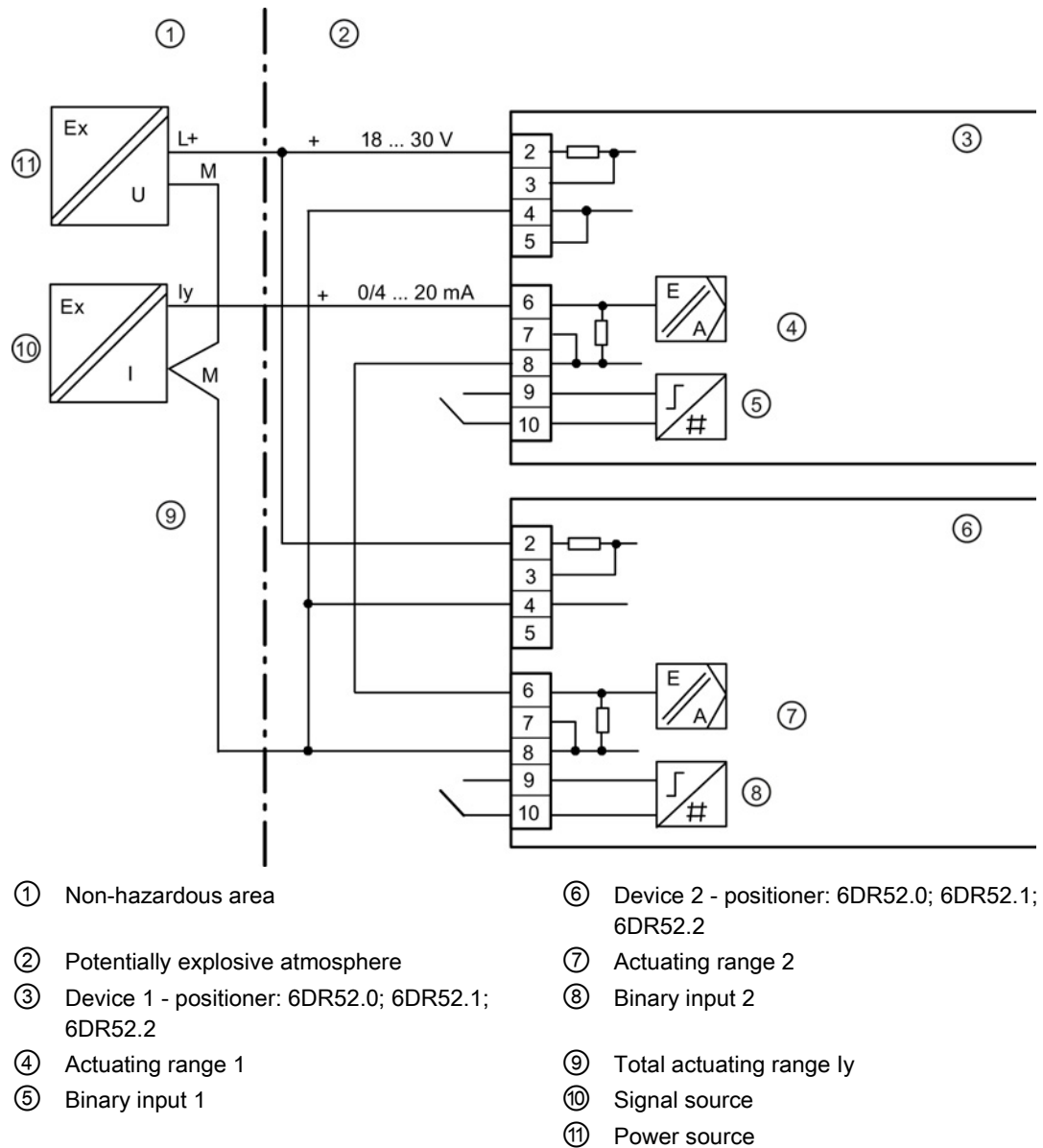

Figure 5-15 Series connection of 2 positioners, e.g. split range (auxiliary power wired separately), Ex i/Ex n/Ex t

5.1.4.3 Option modules Ex i/Ex n/Ex t

Which option module is fitted in which positioner

The order number of the positioner is present on its nameplate. This coded order number indicates which option module is already installed in your device. The following table lists the assignment between positioner and installed option module.

List of option modules fitted in positioners with the following types of protection:

- Intrinsic safety "Ex i"
- Non-incendive "Ex nA"
- Protection by enclosure "Ex t"

Positioner	Contains the following installed option module	Order number for installed option module
6DR5..a-0b.1.-0.A.	Alarm module ATEX; alarm module FM/CSA	6DR4004-6A; 6DR4004-7A
6DR5..a-0b.2.-0.A.	SIA module	6DR4004-6G
6DR5..a-0b.3.-0.A.	Mechanical limit switch module	6DR4004-6K
6DR5..a-0b..1-0.A.	I <sub>y</sub> module ATEX; I <sub>y</sub> module FM/CSA	6DR4004-6J; 6DR4004-7J
6DR5..a-0b..2-0.A.	I <sub>y</sub> module ATEX; I <sub>y</sub> module FM/CSA	6DR4004-6J; 6DR4004-7J
6DR5..a-0b..3-0.A.	EMC filter module	C73453-A430-D23

a = 0; 1 or 2

b = E, D, F, G, K

The captions of the following connection graphics for the option modules are made up of the name and order number of the option module.



Alarm module Ex i/Ex n/Ex t

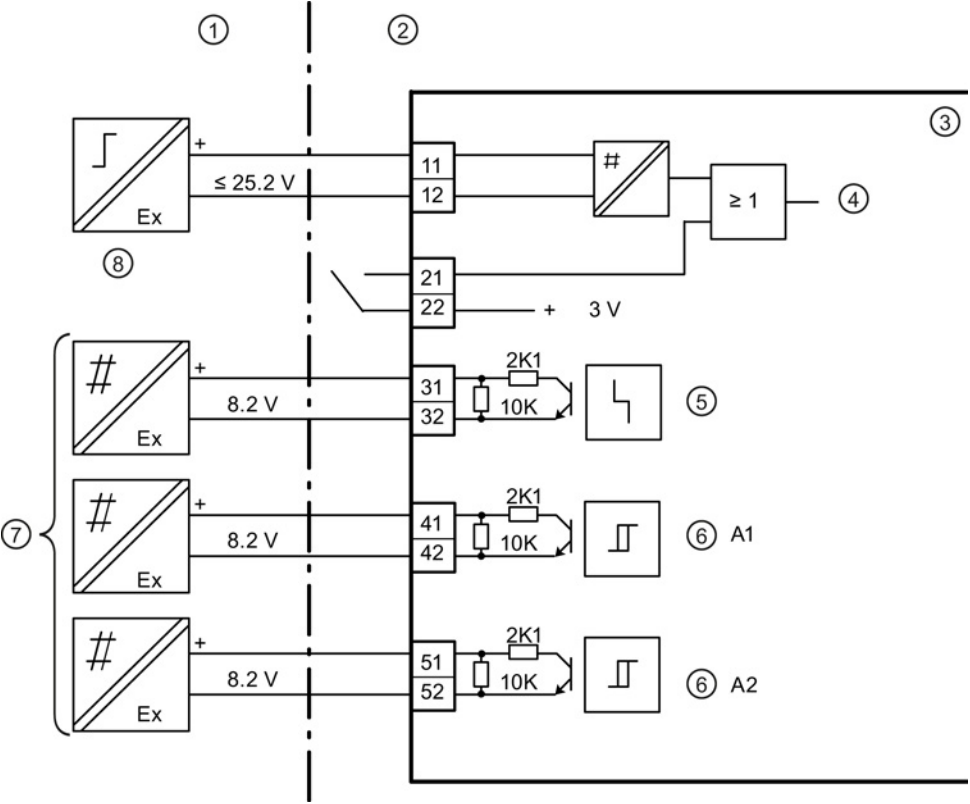

- ① Non-hazardous area
- ② Potentially explosive atmosphere
- ③ Alarm module
- ④ Binary input 2
- ⑤ Fault message
- ⑥ Limit
- ⑦ Switching amplifier
- ⑧ Switching output

Figure 5-16 Alarm module 6DR4004-6A and 6DR4004-7A (Ex i/Ex n/Ex t)



### Limit contact module Ex i/Ex n/Ex t

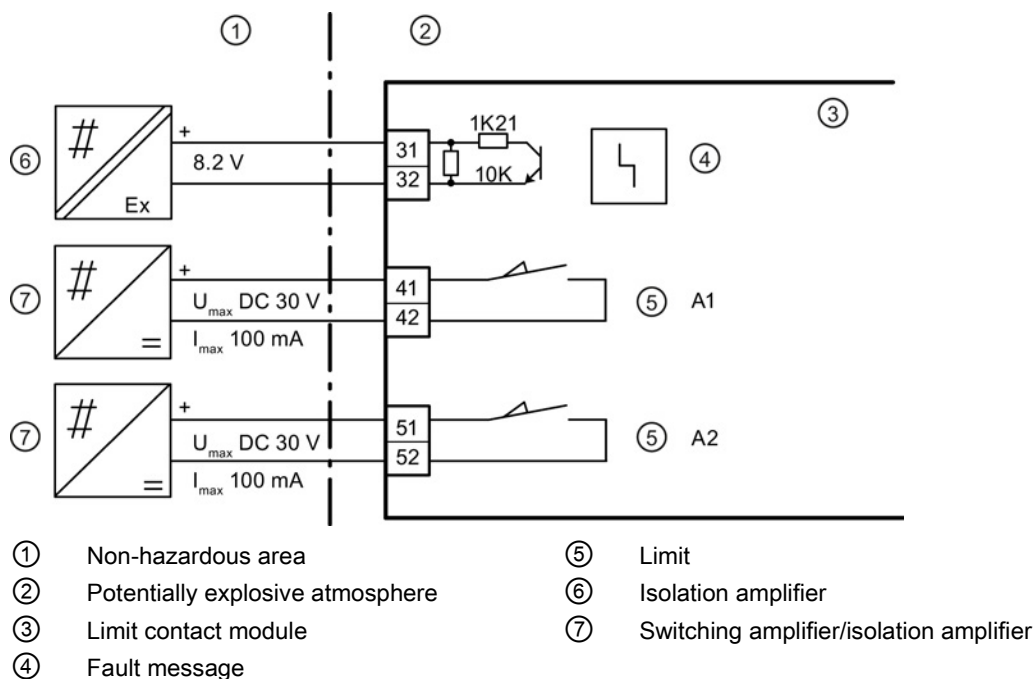
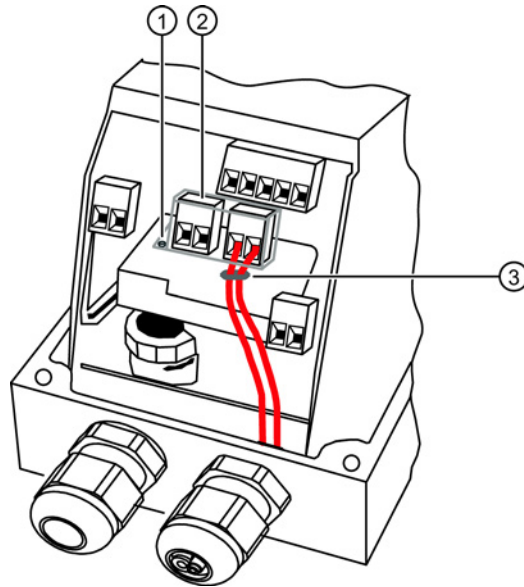

Figure 5-19 Limit contact module 6DR4004-6K (Ex i/Ex n/Ex t)

### Procedure

1. Loosen the screw ① on the transparent cover ②.
2. Pull the transparent cover ② up to the front end stop.
3. Tighten every cable in the corresponding terminal.
4. Slide the transparent cover ② up to the end stop of the basic electronics.

5. Tighten the screw ① on the transparent cover ②.
6. Connect the cables of each switch to the lug of the printed circuit board in pairs. Use the provided cable ties ③ for this purpose.



- ① Screw
- ② Cover
- ③ Cable tie

Figure 5-20 Connecting the cables

### 5.1.5 Connecting NCS to EMC filter module

#### Requirements

You need the EMC filter module with order number C73451-A430-D23 to connect the NCS to the positioner. The positioner supplies auxiliary power to the NCS via the EMC filter module.

#### Wiring diagram

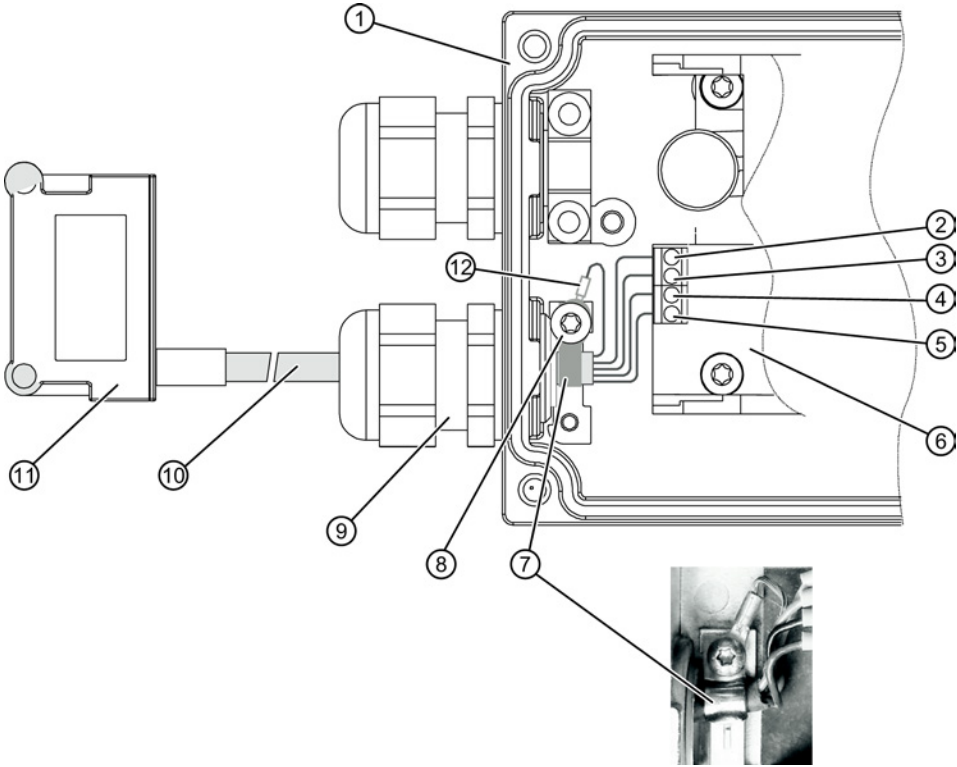

- |   |                                   |   |                             |
|---|-----------------------------------|---|-----------------------------|
| ① | Positioner (open state)           | ⑦ | Cable clamp                 |
| ② | Vcc: Yellow                       | ⑧ | Screw F3x8                  |
| ③ | Vref: Green                       | ⑨ | Cable gland                 |
| ④ | Vpos: Black                       | ⑩ | Four-pole NCS cable         |
| ⑤ | Ground: Brown                     | ⑪ | Non contacting sensor (NCS) |
| ⑥ | EMC filter module C73451-A430-D23 | ⑫ | Cable shielding lug         |

Figure 5-21 Example of connecting the NCS to the EMC filter module

## Procedure

The NCS is equipped with a shielded four-pole cable. Wire this cable to the positioner as follows:

1. Feed the four-pole NCS cable ⑩ through the union nut and the cable gland. Note: The type of cable gland depends on the positioner version.
2. Tighten the cable gland ⑨.
3. Terminate the four-pole NCS cable ⑩ in the positioner in accordance with the wiring diagram.
4. Place the cable clamp ⑦ onto the outer insulation of the four-pole NCS cable ⑩.
5. Use the screw ⑧ to bond the cable shielding lug ⑫ and the cable clamp ⑦ to the ground terminal of the positioner.
6. Grounding:

The rear steel panel of the NCS is inevitably bonded to ground potential of the system by mounting the console. This ground connection is only functional if there is a low-impedance connection to ground potential of the system. Ensure this state by measuring ground resistance. If necessary, ensure proper grounding by means of an additional cable from the NCS to ground potential.

### 5.1.6 Connecting the external position detection system to the EMC filter module

#### Requirements

You need the EMC filter module with Order No. C73451-A430-D23 for the electrical connection of an external position detection system C73451-A430-D78, an external potentiometer, or an NCS sensor to the positioner.

---

#### Note

##### Different cable glands

A blue and a gray cable gland are provided to distinguish between explosion-proof and not explosion-proof devices.

- Use the blue cable gland for explosion-proof devices in "intrinsically safe" protection type. Use the gray cable gland for all other designs.
-

## Wiring diagram

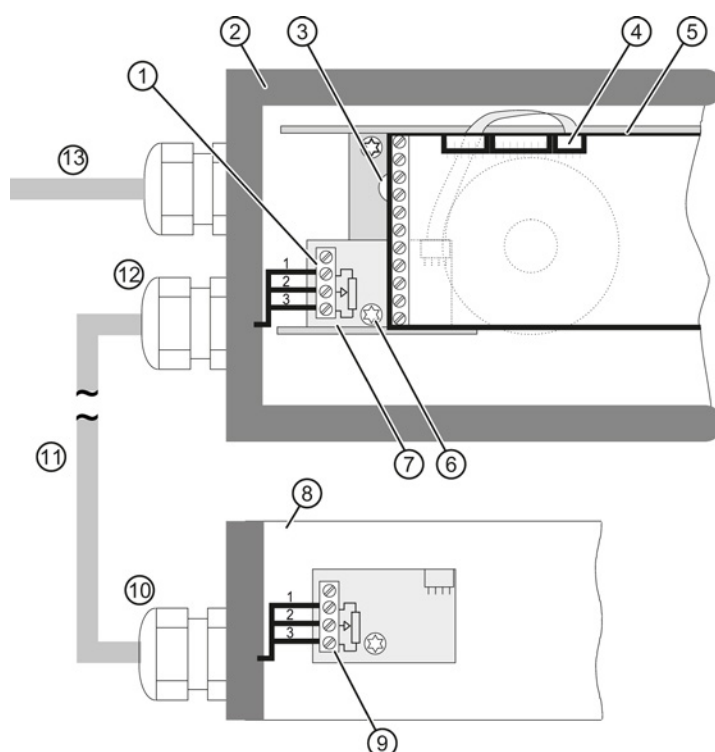

- |   |  |   |  |
|---|--|---|--|
| ① | EMC filter module terminals  | ⑧ | External position detection system C73451-A430-D78 or external potentiometer |
| ② | Positioner with integral EMC filter module C73451-A430-D23                                     | ⑨ | External position detection system terminals                                 |
| ③ | Yellow wheel for locking the position detection  | ⑩ | External position detection system cable gland                               |
| ④ | Ribbon cable connector of fitted potentiometer, or ribbon cable connector of EMC filter module | ⑪ | Cable  |
| ⑤ | Basic electronics  | ⑫ | EMC filter module cable gland  |
| ⑥ | Screw  | ⑬ | Input signal for positioner  |
| ⑦ | EMC filter module C73451-A430-D23  |   |  |

Figure 5-22 Connection to positioner

## Preparing the positioner

1. Unplug the ribbon cable connector ④ to the fitted potentiometer from the basic electronics ⑤.
2. Remove the basic electronics ⑤ from the positioner. To this end, remove the two screws that fix the basic electronics to the pneumatic block.
3. Loosen screw ⑥ in the connection area of the positioner.

4. Then, secure the loose ribbon cable (B) on the wall of the rack as shown in the following graphic. To do this, use the cable tie (A) supplied with the EMC filter module C73451-A430-D23.

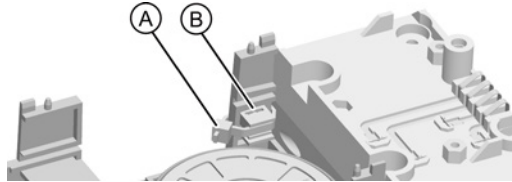

(A) Cable tie

(B) Ribbon cable connector

5. Secure the EMC filter module using the screw ⑥ loosened in the third step.
6. Fit the basic electronics ⑤ back into the positioner.
7. Insert the ribbon cable connector ④ of the EMC filter module onto the positioner basic electronics.
8. In **non-hazardous** environment:
  - Stick the supplied nameplate over the nameplate on the external position detection system ⑧.
  - Replace the blue cable gland ⑩ by the supplied gray cable gland.

Refer to section "Scope of delivery of external position detection system (Page 251)", items "Nameplate for device version **without** explosion protection" and "Gray cable gland".

For further information on fitting of an option module, refer to the operating instructions of the respective positioner version in section "Installing/mounting > Installing option modules".

### Procedure for connecting an external position detection system

1. Connect the three terminals of the external position detection system ⑨ to the three terminals of the EMC filter module ① using a cable as shown in the wiring diagram.
2. Tighten the cable glands ⑩ and ⑫.

### See also

Installing optional modules in the standard and intrinsically safe version (Page 49)



## 5.2 Pneumatic

### 5.2.1 Pneumatic connections

#### 5.2.1.1 Pneumatic connection on the standard controller

##### Structure

The pneumatic connections are provided on the right side of the positioner.

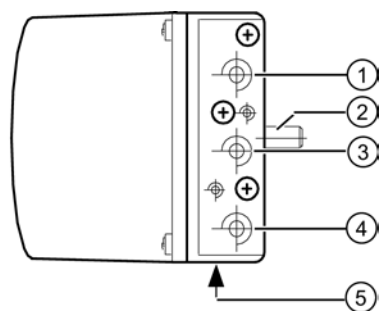

- ① Actuating pressure Y1 for single and double-acting actuators
- ② Positioner axis
- ③ Supply air Pz
- ④ Actuating pressure Y2 for double-acting actuators
- ⑤ Exhaust air outlet with a sound absorber

Figure 5-23 Pneumatic connection on the standard controller

#### 5.2.1.2 Integrated pneumatic connection

##### Structure

The following pneumatic connections are provided at the rear side of the basic device for the integrated attachment for single-acting linear actuators:

- Actuating pressure Y1
- Exhaust air outlet

These connections are sealed with screws when the device is delivered.

The exhaust air outlet is corrosion-resistant for the blanketing of the pick-up room and the spring chamber with dry instrument air.

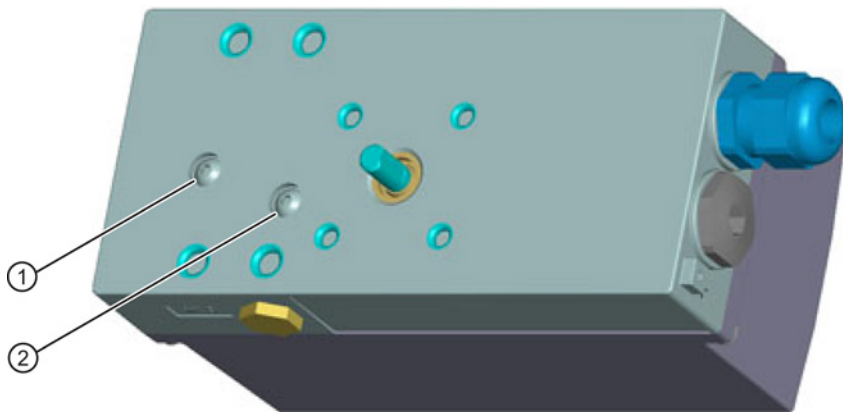

- ① Actuating pressure Y1
- ② Exhaust air outlet

Figure 5-24 Integrated pneumatic connection

### 5.2.1.3 Pneumatic connection in the flameproof enclosure

#### Structure

The pneumatic connections are provided on the right side of the positioner.

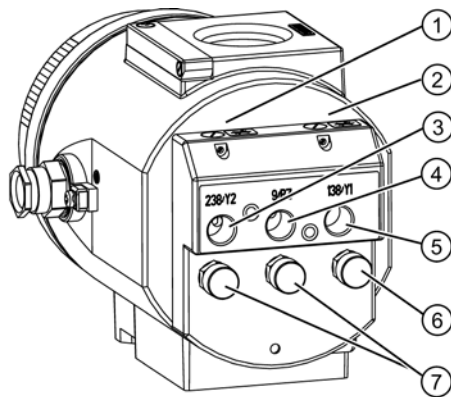

- |                            |                              |
|----------------------------|------------------------------|
| ① Restrictor Y2 *)         | ⑤ Actuating pressure Y1      |
| ② Restrictor Y1            | ⑥ Exhaust air outlet         |
| ③ Actuating pressure Y2 *) | ⑦ Enclosure ventilation (2x) |
| ④ Supply air Pz            |                              |

\*) for double-acting actuators

Figure 5-25 Pneumatic connection in the flameproof enclosure

#### 5.2.1.4 Pneumatic connection versions

##### Overview

For the integrated attachment for single-action linear actuators, the following pneumatic connections are provided at the rear side of the standard controller:

- Actuating pressure Y1
- Exhaust air outlet

These connections are sealed with screws when the device is delivered.

The exhaust air outlet is corrosion-resistant for the blanketing of the pick-up room and the spring chamber with dry instrument air.

The following overview diagram shows the pneumatic connection versions for different actuator types, regulating action and safety position after an auxiliary power supply failure.

 **CAUTION**

**Before working on the control valve**

Note that before working on the control valve, you must first move it to the safety position. Make sure that the control valve has reached the safety position. If you only interrupt the pneumatic auxiliary power supply to the positioner, the safety position may in some cases only be attained after a certain delay period.











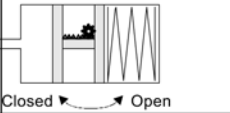

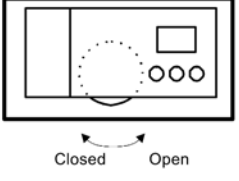
Actuating pressure Connection	Actuator type	Safety position after auxiliary power failure		
		Electric	Pneumatic	
Y1		Closed 	Closed 	<p>With part-turn actuators the counterclockwise direction of rotation - viewed on the actuating shaft of the valve - is defined as "Open".</p> 
Y1		Open 	Open 	
Y2 Y1		Open 	Last position (before auxiliary power failure)	
Y1 Y2		Closed 		
Y1		Closed	Closed	
Y1		Open	Open	
Y2 Y1		Open	Last position (before auxiliary power failure)	
Y1 Y2		Closed		

Figure 5-26 Regulating action of pneumatic connection

## 5.2.2 Pneumatic connection

 **WARNING**

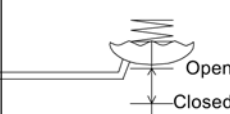
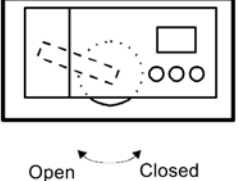
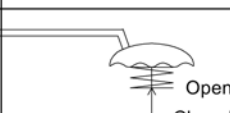
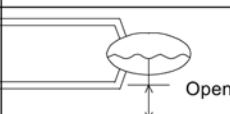
**Pneumatic auxiliary power**

Owing to safety reasons, the pneumatic auxiliary power supply must be fed after installation only if the positioner is switched to the "P-manual mode" when an electrical signal is available, refer to the as-delivered condition.

**Note**

**Specifications regarding air quality**

Observe the specifications regarding the air quality, see section "Pneumatic data (Page 224)".

- If required, connect the pressure gauge block for supply air and actuating pressure.
- Connection via female thread G $\frac{1}{4}$  or  $\frac{1}{4}$ " NPT:
  - Y1: actuating pressure 1 for single and double-acting actuators
  - Y2: actuating pressure 2 for double-acting actuators
  - Exhaust air outlet with a sound absorber at the bottom of the device. Remove the sound absorber if required.
  - Pz: Supply air 1.4 to 7 bar
- For double-acting actuators, connect actuating pressures Y1 or Y2 depending on the desired safety position. Safety position in case of electrical auxiliary power supply failure:
  - Y1: Single-acting, depressurized
  - Y1: Double-acting, maximum actuating pressure
  - Y2: double-acting, depressurized

**Note**

**Leakage**

Besides continuous air consumption, the positioner may try to compensate the position deviation due to leakage. This will lead to premature wear in the entire control unit.

- After installing the pneumatic connections, check the tightness of the entire control valve.

**See also**

Changing the operating mode (Page 105)

Pneumatic connection in the flameproof enclosure (Page 96)

Technical data (Page 223)

### 5.3 Restrictors

- Reduce the air output to achieve actuating times of  $T > 1.5$  s for small actuators. Use restrictors Y1 ① and Y2 ② for this purpose.
- When turned clockwise, they reduce the air output and finally shut it off.
- In order to set the restrictors, we recommend closing them and then opening slowly.
- In case of double-acting valves, ensure that both restrictors have approximately the same setting.

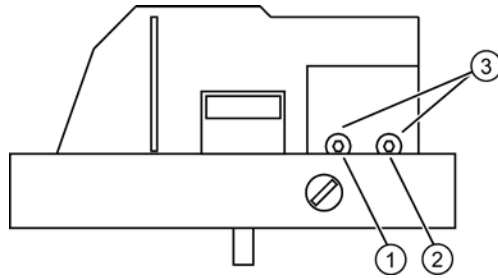

- ① Restrictor Y1
- ② Restrictor Y2, only in the version for double-acting actuators
- ③ Hexagon socket-head screw 2.5 mm

Figure 5-27 Restrictors

**See also**

Pneumatic connection in the flameproof enclosure (Page 96)

Sequence of automatic initialization (Page 115)

## Operating

### 6.1 Operating elements

#### 6.1.1 Display

##### Introduction

**Note**





**Repetition rate display**



When operated in temperature ranges below -10°C, the liquid crystal display of the positioner becomes sluggish and the repetition rate display reduces considerably.

The display has two lines. These two lines are segmented differently. Each element in the upper line has 7 segments, whereas that in the lower line has 14 segments. Contents of the display depend on the selected mode.

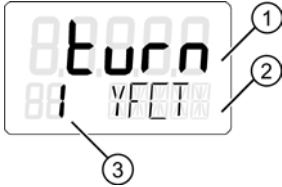
##### Display options as per the mode

An overview of mode-specific display options is given below.

Operating mode	Representation in the display	Pos.	Legend
P manual mode		①	Potentiometer setting [%]
		②	Blinking indicator for the non-initialized status.
Initialization mode		①	Potentiometer setting [%]
		②	Display of the current status of initialization or a fault message.
		③	Indicator for ongoing initialization or a fault message.
Configuring		①	Parameter value
		②	Parameter name
		③	Parameter number
Manual mode (MAN)		①	Position [%]

Operating mode	Representation in the display	Pos.	Legend
		②	Setpoint [%]
		③	Fault message
Automatic (AUT)		①	Position [%]
		②	Setpoint [%]
		③	Fault message
Diagnostics		①	Diagnostics value
		②	Diagnostics name
		③	Diagnostics number

See also

System messages before initialization (Page 191)

Changing the operating mode (Page 105)

6.1.2 Buttons

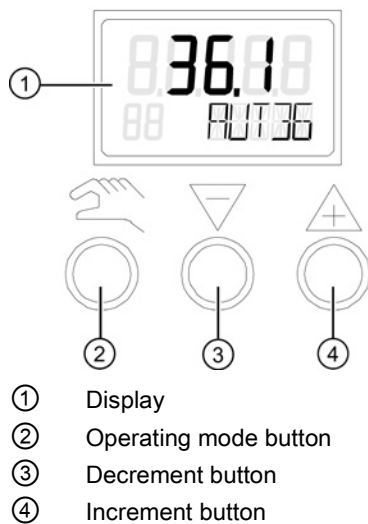

Figure 6-1 Display and buttons of the positioner



- You can use three buttons to operate the positioner.
- The function of the buttons depends on the mode selected.
- In a positioner with a flameproof enclosure, the buttons are protected with a cover. The button cover can be opened after unlatching the locking screw.

---

**Note**

**Key cover**

In positioners with flameproof enclosures, the button cover prevents liquids from seeping through. The IP66/NEMA 4x degree of protection is not ensured when the enclosure or the button cover is open.

---

You have to remove the enclosure cover to operate the buttons of the basic device or the "intrinsically safe" version.

---



**Note**

**Degree of protection**

The IP66/NEMA 4x degree of protection is not ensured as long as the positioner is open.

---



**Function of buttons:**

- The  button is used to select the modes and to forward the parameters.
- The  button is used to select parameter values when configuring. You can use this button to move the actuator in manual mode.
- The  button is also used to select parameter values when configuring. You can use this button to move the actuator in manual mode.

---

**Note**

**Order**

Parameters are activated in the reverse order when the  and  buttons are pressed simultaneously.

---

### 6.1.3 Firmware version

The current firmware version is displayed when you exit the configuration menu.



Figure 6-2 Firmware version, e.g. Version 4.00.00

## 6.2 Operating modes

### 6.2.1 Overview of operating modes

You have five operating modes at your disposal to operate the positioner:

1. P-manual mode (as-delivered condition)
2. Configuration and initialization mode
3. Manual mode (MAN)
4. Automatic (AUT)
5. Diagnostics

## 6.2.2 Changing the operating mode

The following picture illustrates the available operating modes and switching between the operating modes.

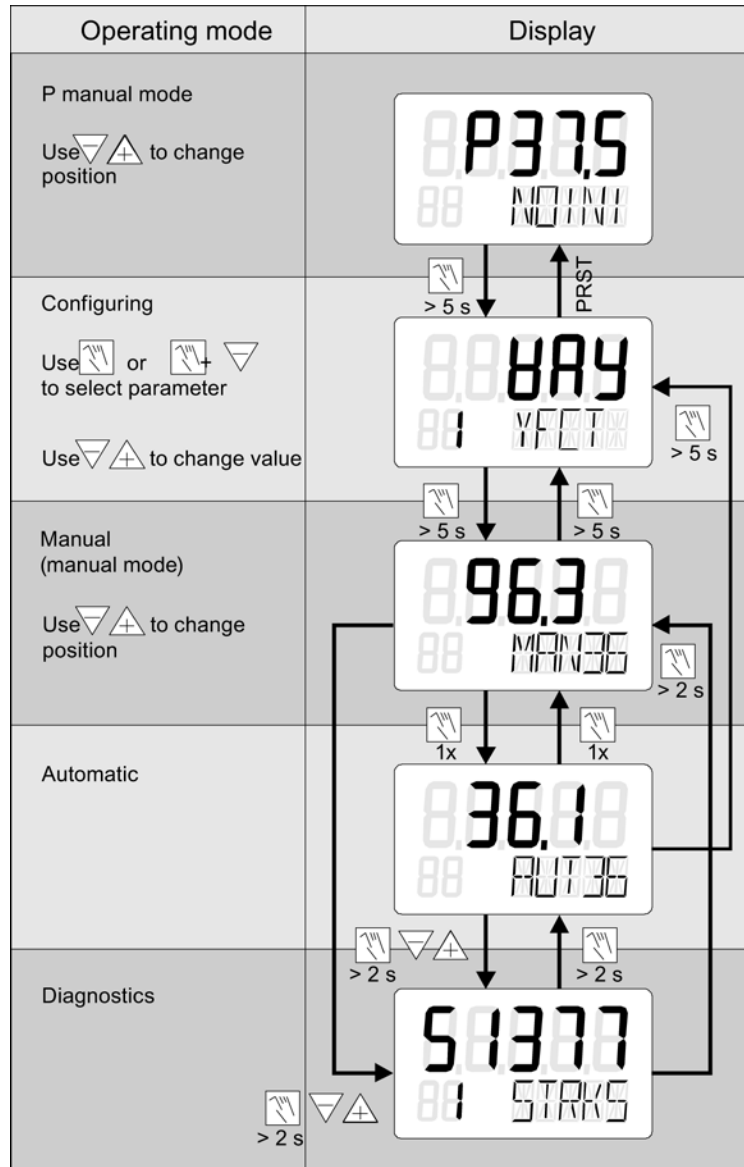

Figure 6-3 Switching between the operating modes

See also

Display (Page 101)

### 6.2.3 Overview of configuration

The following figure shows the operation of the configuration and initialization modes.

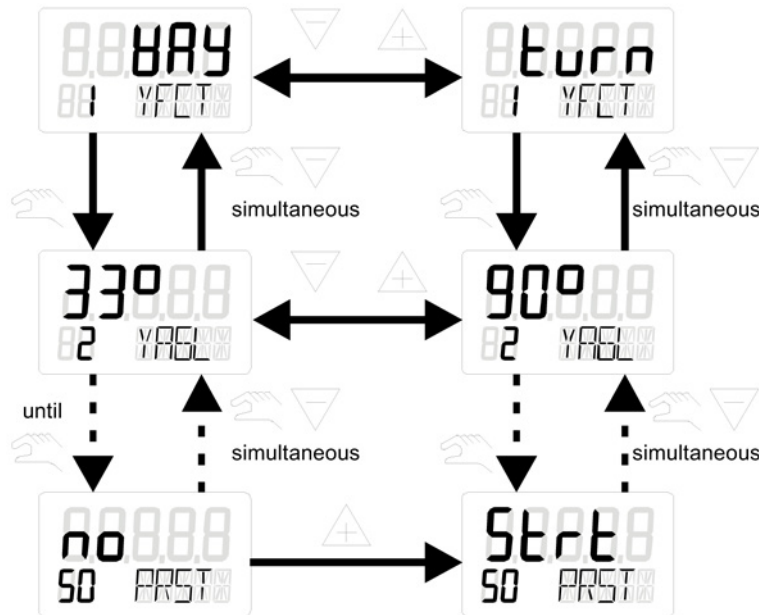

Figure 6-4 Overview of configuration

### 6.2.4 Description of operating modes

#### P manual mode

**Note**

**Delivery state**

The "P manual mode" is preset for the positioner in the delivery state.

The display of the positioner shows the current potentiometer position in the upper line. "NOINI" blinks in the second line of the display.

Move to the actuator with the  $\nabla$  or  $\triangle$  buttons.

Switch to "Configuration" and "Initialization mode" to adapt the actuator as per the positioner.

Alarms or position feedbacks can be triggered after initializing the positioner completely.

## Configuration and initialization

To get to the "Configuration" mode, press the  button for at least 5 seconds.

You can use the "Configuration" mode to adjust the positioner individually as per your actuator and start commissioning or initialization.

The positioner reports the "Configuration" mode with a configurable fault message. A position feedback or display of limits A1 and A2 is not possible.

---

### Note

#### Failure of electrical auxiliary power



If electrical auxiliary power supply fails when configuring, the positioner responds as follows until the power supply is reestablished:

- The positioner switches to the first parameter.
- Settings of the values already configured are retained.

In order to save the changed parameter values, exit the "Configuration" mode or switch to another parameter. When "Configuration" mode is restarted, the output in the display switches to the last activated parameter.

---

## Manual mode (MAN)

In this mode, you move the actuator with  or . The setting selected here is retained irrespective of the setpoint current and leakages, if any.

---

### Note

#### Accelerating the actuator movement

Proceed as follows if you wish to accelerate the actuator movement:

1. Keep one of the two direction buttons pressed.
  2. Press the remaining direction button simultaneously.
- 

### Note

#### Failure of power supply

When the power supply is reestablished after a failure, the positioner switches to the "Automatic" mode.

---

### Automatic (AUT)

Automatic is the standard mode. In this mode, the positioner compares the setpoint position with the actual position. The positioner moves the actuator until the control deviation reaches the configurable deadband. A fault message is displayed if the deadband cannot be reached.

Display	Mode	Meaning
OS	OOS	out of service; reaction: last position is retained.
IMN	IMAN	initialization manual mode
LO	LO	local override
MM	MAN	manual mode
AUT	AUTO	automatic mode
CAS	CAS	cascade mode
RCS	RCAS	remote cascade

### Diagnostics

Proceed as follows to call the "Diagnostics" mode from the "Automatic" or "Manual" modes:

Press the three buttons of the positioner at the same time for at least 2 seconds.

Current operating data can be called and displayed in this mode, e.g.:

- Stroke number
- Number of changes in direction
- Number of fault messages

---

#### Note

##### Setting the mode

The "Automatic" and "Manual" modes remain set when switching to the "Diagnostics" mode. The positioner responds as per the configured mode:

- The predefined setpoint is used as a control variable in the automatic mode.
  - The last reached position is retained in the manual mode.
- 

### See also

Commissioning (Page 111)

Overview parameters A to P (Page 151)

Overview of diagnostics values (Page 197)

Meaning of the diagnostics values (Page 200)

## 6.3 Optimizing the controller data

---

### Note

#### Initializing

Initialize the positioner automatically before changing the parameter settings as per your specific requirements.

---

The positioner determines the data for control quality automatically during the initialization process.

The data determined is optimized for a short transient time in case of minor overshoots.

The adjustment can be accelerated or the attenuation can be intensified by optimizing the data.

The following special cases are ideal examples for a targeted data optimization:

- Small actuators with actuating times < 1 s.
- Operation with boosters, described in section "Operation with boosters (Page 255)"

### Procedure

1. Select the parameters in the diagnostics menu. Press the three buttons of the positioner at the same time for at least 2 seconds.
2. Activate the setting function. Press the  $\triangle$  or  $\nabla$  button for at least 5 seconds.
3. When you change the selected parameter, it is immediately updated. The effects on the controller results can then be tested.

In order to optimize the controller data, change the values of the parameters listed below.

### 22 Impulse length up / 23 Impulse length down

You can use these parameters to determine the smallest impulse lengths for each actuating direction. The actuator is then moved with these lengths. The optimum value depends on the volume of the actuator in particular. Small values lead to small controller increments and frequent activation of the actuator. Large values are advantageous for large actuator volumes.

---

### Note

#### Controller increments

- There is no movement if the values are too small.
  - Large controller increments also lead to large movements in case of small actuators.
- 

### 26 Slow step zone up / 27 Slow step zone down

The slow step zone is the area of mean control deviation. For more information on the slow step zone, refer to the chapter "Control algorithm (Page 25)".

Select small values to achieve high speeds of shifting with small control deviations already.  
Select large values to reduce overshoots particularly in case of large changes in the setpoint.

**NOTICE**

**Overshoots or too low speeds of shifting**

Too small values can result in overshoots.

- Enter a higher value.

Too large values result in too slow speeds of shifting near the adjusted status.

- Enter a smaller value.

**43 Prediction up / 44 Prediction down**

These parameters work similar to attenuation factors. These parameters are used to set the control dynamics. The parameter settings have the following results:

- Small values result in quick adjustments with overshoots.
- Large values result in slow adjustments without overshoots.

---

**Note**

**Reference variable**

It is advantageous to use a fixed reference variable to optimize the control data.  
Therefore, change the deadband parameter from auto to a fixed value.

---



## 7.1 Basic safety instructions

 <b>WARNING</b>
<b>Improper commissioning in hazardous areas</b> Device failure or danger of explosion in hazardous areas. <ul style="list-style-type: none"><li>• Do not commission the device until it has been mounted completely and connected in accordance with the information in Chapter "Technical data (Page 223)".</li><li>• Before commissioning take the effect on other devices in the system into account.</li></ul>

 <b>WARNING</b>
<b>Loss of explosion protection</b> Danger of explosion in hazardous areas if the device is open or not properly closed. <ul style="list-style-type: none"><li>• Close the device as described in Chapter "Technical data (Page 223)".</li></ul>

 <b>WARNING</b>
<b>Opening device in energized state</b> Danger of explosion in areas subject to explosion hazard. <ul style="list-style-type: none"><li>• Only open the device in a de-energized state.</li><li>• Check prior to commissioning that the cover, cover locks, and cable inlets are assembled in accordance with the directives.</li></ul> <b>Exception:</b> Devices having the type of protection "Intrinsic safety Ex i" may also be opened in energized state in hazardous areas.

 **WARNING**

**Water in compressed air line**

Device damage and possibly loss of type of protection. The factory setting for the purging air selector is "IN". In the "IN" position, water from the compressed air line may enter the device from the pneumatics during initial commissioning.

- Before commissioning, make sure that no water is present in the compressed air line.

If you cannot be sure that there is no water in the compressed air line:

- Set the purging air selector to "OUT". In this way, you prevent water from the compressed air line from penetrating the device.
- Only set the purging air selector to "IN" again when all water has been discharged from the compressed air line.

 **CAUTION**

**Loss of degree of protection**

Damage to device if the enclosure is open or not properly closed. The degree of protection specified on the nameplate or in Chapter "Technical data (Page 223)" is no longer guaranteed.

- Make sure that the device is securely closed.

 **WARNING**

**Commissioning and operation with pending error**

If an error message appears, correct operation in the process is no longer guaranteed.

- Check the gravity of the error
- Correct the error
- If the error still exists:
  - Take the device out of operation.
  - Prevent renewed commissioning.

When operating the positioner with natural gas, you must follow and adhere to the following safety notes:

** WARNING****Operation with natural gas**

1. Only the "Ex ia" version of the positioner and option modules with the "Ex ia" type of protection may be operated with natural gas. Positioners with other types of protection, e.g. flameproof enclosure or versions for zones 2 and 22 are not permitted.
2. Do not operate the positioner with natural gas in closed spaces.
3. Natural gas is continuously blown off in the servo-drive depending on the model. Special care must therefore be taken during maintenance activities near the positioner. Always ensure that the immediate surroundings of the positioner are adequately ventilated.  
The maximum values for ventilation are listed in section "Technical data for natural gas as actuator medium (Page 231)".
4. The limit contact module may not be used when operating the positioner with natural gas.
5. Depressurize the devices operated with natural gas adequately during maintenance activities. Open the cover in an explosion-free atmosphere and depressurize the device for at least two minutes.

**Note****Quality of natural gas**

Only use natural gas which is clean, dry and free from additives.

**Note**

- During the initialization process, the operating pressure must be at least one bar more than that required to close or open the valve. However, the operating pressure should not be greater than the maximum permissible operating pressure for the actuator.
- The transmission ratio selector can be set only when the positioner is open. Therefore, check this setting before closing the enclosure.

**General information about commissioning**

After installing the positioner on a pneumatic actuator, you must supply electric and pneumatic auxiliary power to it.

The positioner is in the "P manual mode" before initialization. At the same time, "NOINI" blinks in the lower line of the display.

Adjust the positioner as per the respective actuator with the help of the initialization process and by setting the parameters. If required, use the "PRST" parameter to cancel the adjustment of the positioner on the actuator. The positioner is again in the "P manual mode" after this process.

## Types of initialization

You can initialize the positioner as follows:

- Automatic initialization:  
during automatic initialization, the positioner determines the following one after the other:
  - The direction of action
  - The actuator travel and angle of rotation
  - Movement times of the actuator

The positioner also adjusts the control parameters as per the dynamic response of the actuator.

- Manual initialization:  
the actuator travel and the angle of rotation of the actuator are set manually. The remaining parameters are automatically determined. This function is useful for actuators with soft end stops.
- Copying the initialization data when replacing a positioner:  
the initialization data of a positioner can be read and copied into another positioner. A defective device can thus be replaced without interrupting an ongoing process through initialization.

You have to define a few parameters for the positioner before initialization. Owing to the preset values, you cannot adjust further parameters for initialization.

You can use a suitably configured and activated binary input to protect the configured settings against accidental adjustment.

## See also

Overview of operating modes (Page 104)

## 7.2 Sequence of automatic initialization

### Overview

The automatic initialization takes place in the following phases:

Automatic initialization phase	Description
Start	-
RUN1	Establishing the direction of action.
RUN2	Checking the actuator travel and trimming the zero point and the stroke.
RUN3	Establishing and display of the actuating time (leak monitoring)
RUN4	Minimization of controller increments
RUN5	Optimization of the transient response
End	-

The following structured charts describe the sequence of initialization. The "Up/Down" names indicate the direction of action of actuators.

#### Linear actuator

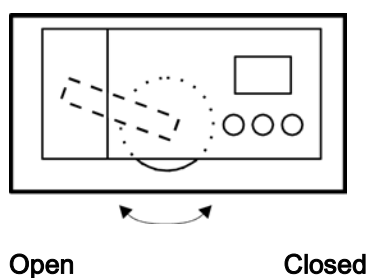

#### Part-turn actuator

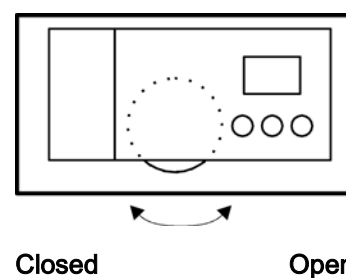



### Sequence of RUN2 for part-turn actuators

This structured chart describes the sequence for checking the actuator travel. It also contains the information about the sequence for trimming the zero point and the stroke.

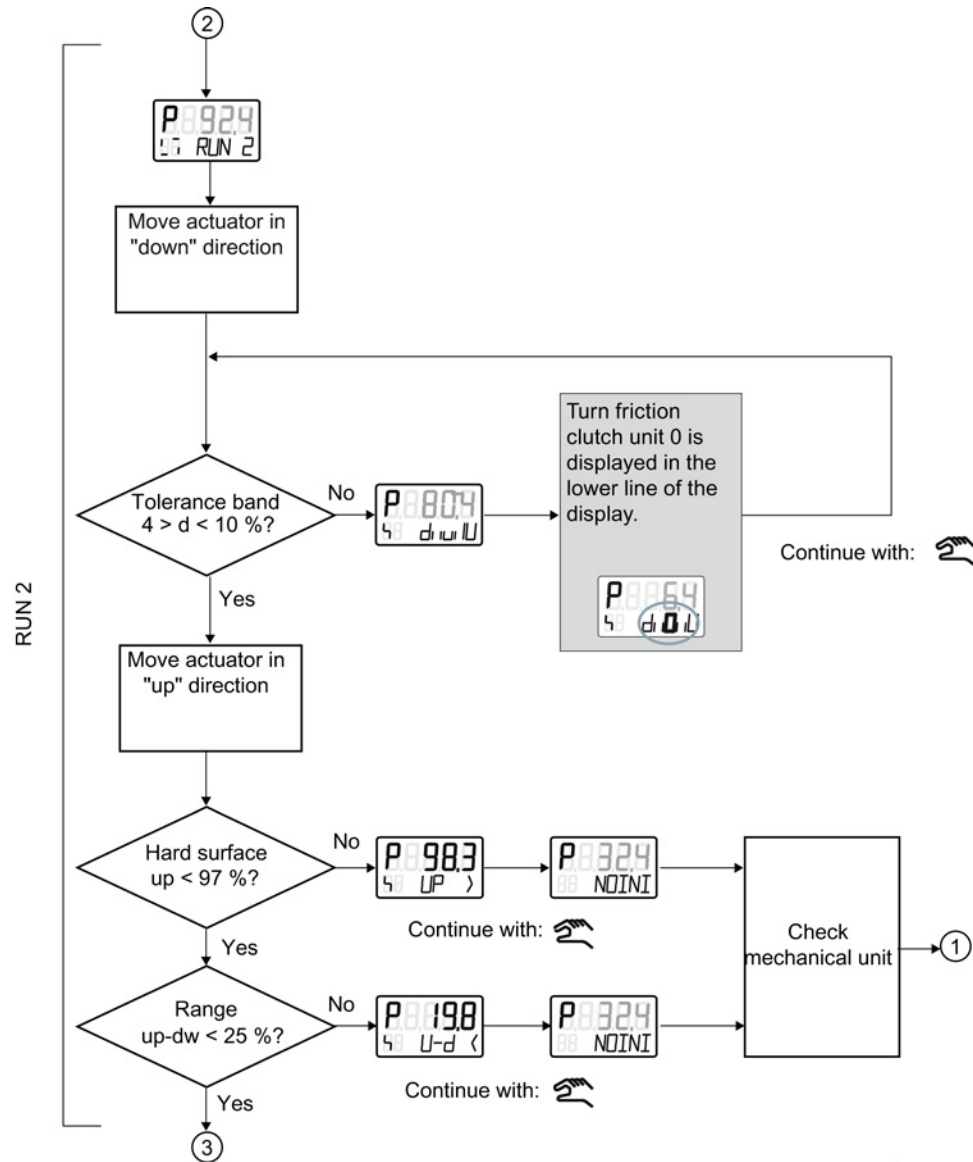

Manual intervention

Sequence of RUN2 for linear actuators

This structured chart describes the process to determine the actuator travel checks. It also contains the information about the sequence for trimming the zero point and the stroke.

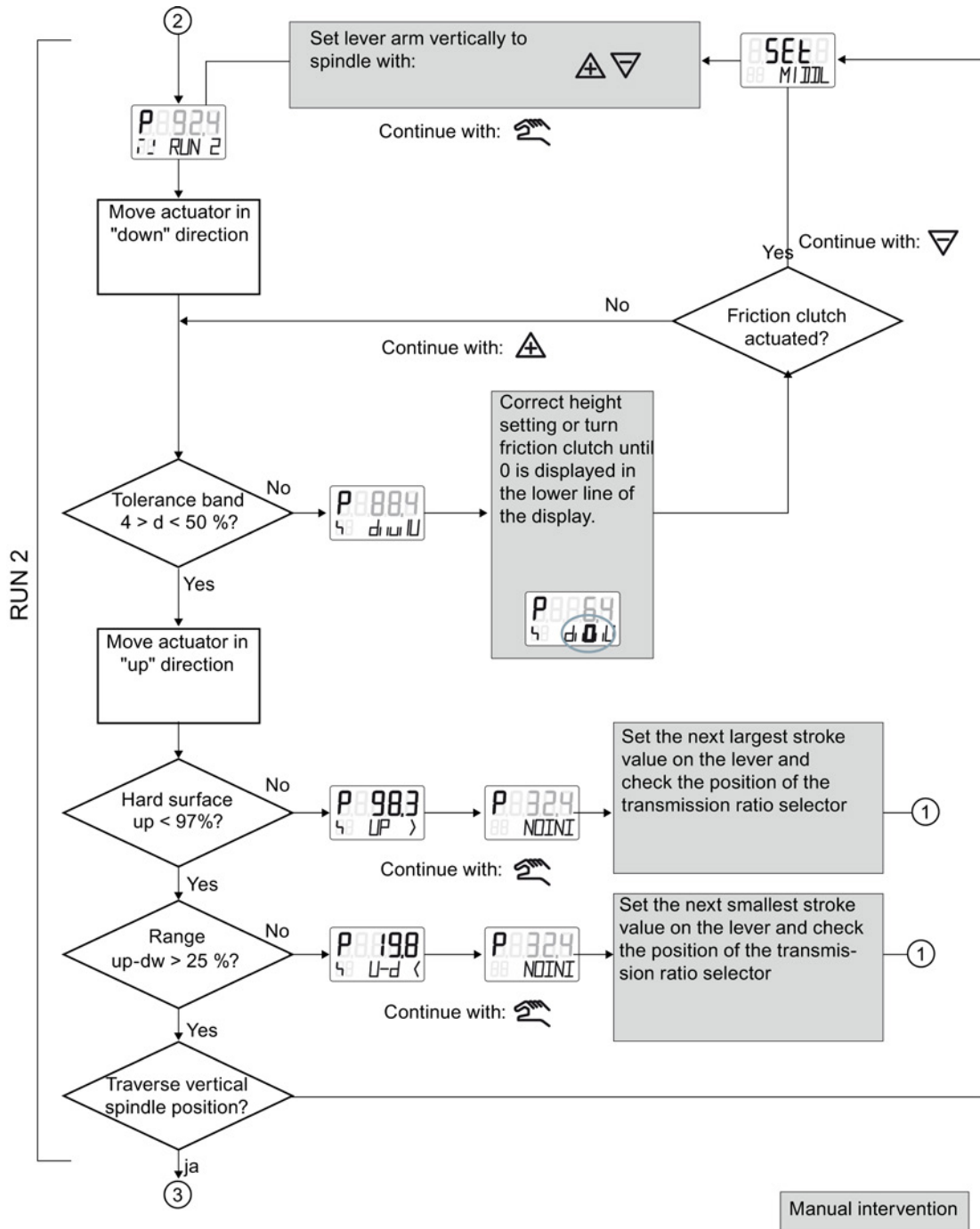



### Sequence of RUN3 to RUN5

This structured chart describes:

- Establishing and display of the actuating time/leak monitoring in RUN3
- Minimization of controller increments in RUN4
- Optimization of the transient response in RUN5

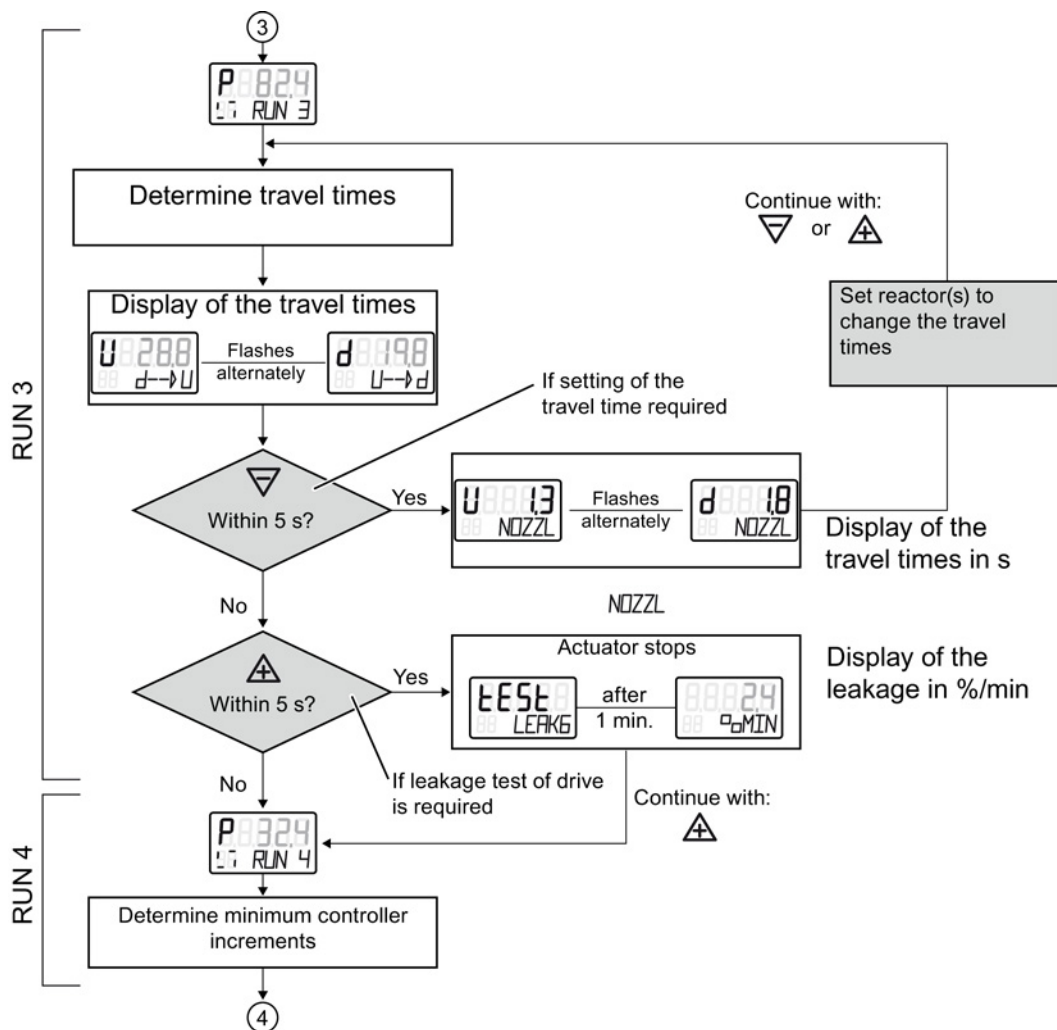

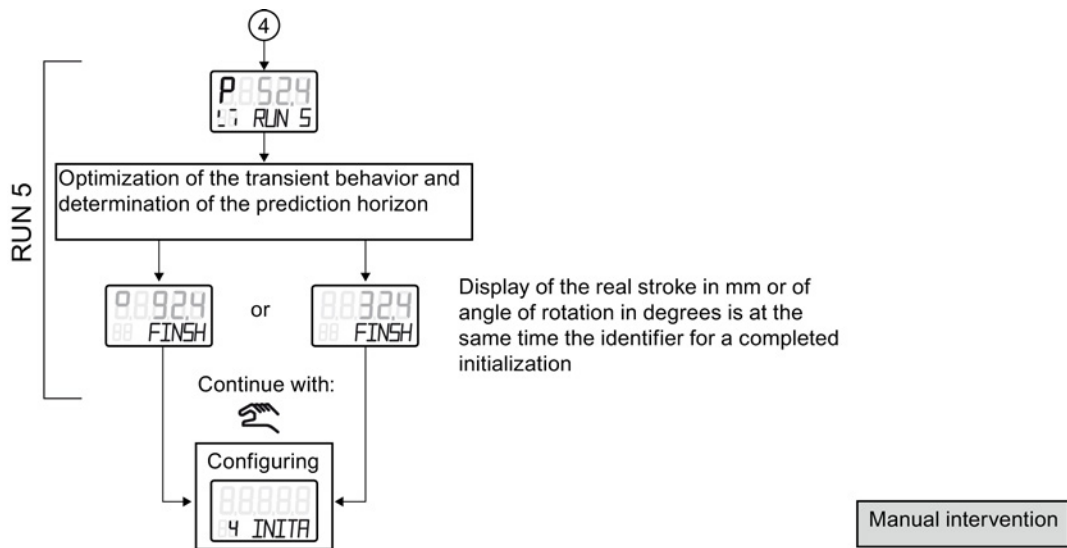

### 7.3 Purge air switching

When the enclosure is open, the purge air switch above the pneumatic terminal strip on the pneumatic block can be accessed.

- In the IN position, the enclosure is flushed from inside with a small volume of clean and dry instrument air.
- In the OUT position, the purge air is directly directed towards outside.

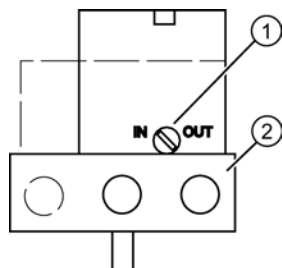

- ① Purging air selector
- ② Pneumatic connections Y1, Pz and Y2

Figure 7-1 Purge air switch on the pneumatic block; view of the positioner on the pneumatic connection side when the cover is open

The factory setting is the "IN" position.

## 7.4 Commissioning linear actuators

### 7.4.1 Preparing linear actuators for commissioning

#### Requirements

You have already installed the positioner using the suitable mounting kit.

#### Setting the transmission ratio selector

##### Note

##### Commissioning

The setting of the transmission ratio selector is extremely important to commission the positioner.

Stroke [mm]	Lever	Position of the transmission ratio selector	
		In [°]	Position
5 ... 20	Short	33	Down
15 ... 35	Short	90	Up
30 ... 130	Long	90	Up

1. Move the carrier pin on the lever. Select the scale position equal to the nominal stroke or a next-higher position.
2. Tighten the carrier pin using the M6 hexagon nut.

#### Connecting the positioner

1. Connect a suitable current or voltage source. The positioner is now in the "P manual mode". The current potentiometer voltage (P) in percent is shown in the upper line of the display, e.g.: "P12.3", and "NOINI" blinks in the lower line:



2. Connect the actuator and the positioner to the pneumatic lines.
3. Supply the pneumatic auxiliary power to the positioner.

### Setting the actuator

1. Check whether the mechanical unit can be moved freely in the entire actuating range. Move the drive to the respective end position for this purpose using the  $\triangle$  or  $\nabla$  button.

---

**Note**

**End position**

By simultaneously pressing the  $\triangle$  and  $\nabla$  buttons, you reach the end position faster.

---

2. Now move the actuator to the horizontal position of the lever.
3. A value between "P48.0" and "P52.0" is shown on the display.
4. If a value beyond this value range is shown on the display, you must move the friction clutch. Move the friction clutch until a value between "P48.0" and "P52.0" is achieved. The closer this value is to "P50.0", the more accurately the positioner determines the stroke travel.

---

**Note**

**The following is applicable for the flameproof enclosure version:**

The inner friction clutch is fixed. Therefore, only move the outer friction clutch.

---

### See also

Mounting the linear actuator (Page 32)

Installing the optional modules in the "flameproof enclosure" version (Page 52)

External position detection (Page 48)

Overview of device components (Page 22)

## 7.4.2 Automatic initialization of linear actuators

### Requirements

The following conditions must be fulfilled before activating the automatic initialization:

1. The actuator spindle can be moved completely.
2. The actuator spindle is at a central position after moving.

## Initializing the linear actuator automatically

### Note

#### Interrupting initialization

An ongoing initialization can be interrupted at any time. To do this, press . The settings configured until then are retained.

All parameters are reset to factory settings only if you have explicitly activated the preset settings in the "PRST" parameter.



1. Switch to the "Configuration" mode. To do this, press the  button for at least 5 seconds.

The display shows the following:

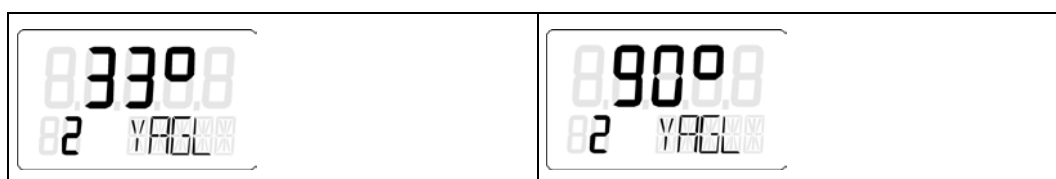

2. Call the "2.YAGL" parameter. To do this, briefly press the  button. The following is shown on the display depending on the setting:



3. Check whether the value displayed in the "2.YAGL" parameter matches the setting of the transmission ratio selector. If required, change the setting of the transmission ratio selector to 33° or 90°.
4. Set the "3.WAY" parameter to determine the total stroke in mm. The setting of parameter 3 is optional. The display shows the determined total stroke only at the end of the initialization phase.
  - Briefly press the  button if you do not require any information about the total stroke in mm. You are then directed to parameter 4.
  - Call the "3.YWAY" parameter. To do this, briefly press the  button. The display shows the following:



---

**Note**

**Set the "3.YWAY" parameter**

Proceed as follows to set parameter 3:

1. On the scale of the lever, read the value marked by the carrier pin.
  2. Set the parameter with the buttons or to the read value.
- 

5. Call the "4.INITA" parameter. To do this, briefly press the  button. The display shows the following:



6. Start the initialization process. To do this, press the  button for at least 5 seconds until the display shows the following:



The positioner runs through five initialization steps during the automatic initialization process. Displays for the initialization steps from "RUN 1" to "RUN 5" are shown in the lower line on the display. The initialization process depends on the actuator used, and takes up to 15 minutes.

7. The following display indicates that the automatic initialization is complete:



### Aborting the automatic initialization process

1. Press the  button. The display shows the following:

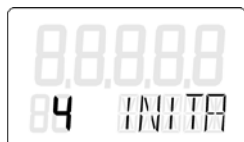

The positioner is in the "Configuration" mode.

2. Exit the "Configuration" mode. To do this, press the  button for at least 5 seconds.

The software status is displayed.

After releasing the  button, the positioner is in "P manual mode". The positioner is not initialized.

### See also

Sequence of automatic initialization (Page 115)

### 7.4.3 Manual initialization of linear actuators

You can use this function to initialize the positioner without needing to move the actuator to the end stops. The start and end positions of the actuator travel are set manually. When the control parameters are optimized, the further initialization process runs automatically.

### Requirements

The following requirements must be fulfilled before activating manual initialization:

1. The positioner has been prepared for using on linear actuators.
2. The actuator spindle can be moved completely.
3. The displayed potentiometer position is within the permissible range between "P5.0" and "P95.0".



### Initializing the linear actuator automatically

1. Switch to the "Configuration" mode. To do this, press the  button for at least 5 seconds until the display shows the following:

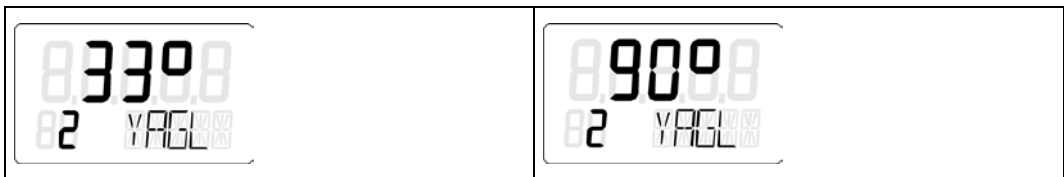

2. Call the "2.YAGL" parameter. To do this, briefly press the  button. The following is shown on the display depending on the setting:



3. Check whether the value displayed of the "2.YAGL" parameter matches with the setting of the transmission ratio selector. If required, change the setting of the transmission ratio selector to 33° or 90°.
4. Set the "3.YWAY" parameter to determine the total stroke in mm. The setting of the "3.YWAY" parameter is optional. The display shows the determined total stroke only at the end of the initialization phase.
  - Briefly press the  button if you do not require any information about the total stroke in mm. You are then directed to parameter 4.
  - Call the "3.YWAY" parameter. To do this, briefly press the  button. The display shows the following:





---

#### Note

##### Set the "3.YWAY" parameter

To set the "3.YWAY" parameter proceed as follows:

1. On the scale of the lever, read the value marked by the carrier pin.
  2. Set the parameter to the read value with the  or  button.
-



5. Call the "5.INITM" parameter. To do this, press the  button twice. The display shows the following:





6. Start the initialization process. To do this, press the  button for at least 5 seconds until the display shows the following:



The current potentiometer position is output on the display after 5 seconds. Examples of the displayed potentiometer positions are given below:



7. Determine the end position 1 of the actuator spindle.  
 8. Move the actuator to the desired position using the  or  button.  
 9. Press the  button. The current position of the actuator is applied. The display shows the following:









---

#### Note

##### RANGE fault message

The selected end position is beyond the permissible measuring range if the "RANGE" message is output on the display. Correct the settings as follows:

1. Move the friction clutch until the display shows "OK".
  2. Press the  button.
  3. Move the actuator to another position using the  or  button.
  4. Abort the manual initialization process by pressing the  button.
  5. Then return to "P manual mode" mode.
  6. Correct the actuator travel and the position detection.
- 

10. Determine the end position 2 of the actuator spindle. Move the actuator to the desired position using the  or  button.



11. Press the  button. The current position of the actuator is applied.

---

**Note**

**Fault message "Set Middl"**

The lever arm is not in the horizontal position if the "Set Middl" message is output on the display. To correct the fault, set the reference point of the sine correction. Proceed as follows:

1. Move the lever arm to the horizontal position using the  or  button.
2. Press the  button.

- 
12. The initialization process is automatically resumed. Initialization steps "RUN1" to "RUN5" are output in the bottom line of the display. The following is displayed when the initialization has been completed successfully:



---



**Note**

**Total stroke**

If the "3.YWAY" parameter has been set, the display shows the total stroke in mm.

---

### Aborting the manual initialization process

1. Press the  button. The display shows the "5.INITM" parameter. The positioner is in the "Configuration" mode.
2. Exit the "Configuration" mode. To do this, press the  button for at least 5 seconds. The software status is displayed. After releasing the  button, the positioner is in "P manual mode". The positioner is not initialized.

## 7.5 Commissioning part-turn actuators

### 7.5.1 Preparing part-turn actuators for commissioning

---

#### Note

##### Setting of the adjustment angle

The usual adjustment angle for part-turn actuators is 90°.

- Set the transmission ratio selector in the positioner to 90°.
- 

#### Condition

The following conditions must be fulfilled before activating the initialization:

1. You have installed the positioner for the part-turn actuators using the suitable mounting kit.
2. You have connected the actuator and the positioner to the pneumatic lines.
3. Pneumatic auxiliary power is supplied to the positioner.
4. The positioner has been connected to a suitable current or voltage source.

#### Setting the actuator

1. The positioner is in the "P manual mode". The current potentiometer voltage P in percent is shown on the upper line in the display. "NOINI" blinks in the lower line of the display. Examples of corresponding displays are given below:



2. Check whether the mechanical unit can be moved freely in the entire actuating range. Move the drive to the respective end position for this purpose using the  $\triangle$  or  $\nabla$  button.

---

#### Note

##### End position

By simultaneously pressing the  $\triangle$  and  $\nabla$  buttons, you reach the end position faster.

---

3. After checking, move the actuator to a central position. This accelerates the initialization process.

**See also**

External position detection (Page 48)

Pneumatic connection (Page 99)

Basic device without Ex protection / in flameproof enclosure "Ex d" (Page 74)

## 7.5.2 Automatic initialization of part-turn actuators

### Requirements

The following conditions must be fulfilled before activating the automatic initialization:

1. The actuating range of the actuator can be passed through completely.
2. The actuator shaft is at a central position.

### Initializing the part-turn actuator automatically

---

**Note**

**Interrupting initialization**

An ongoing initialization can be interrupted at any time. To do this, press . The settings configured until then are retained.

All parameters are reset to factory settings only if you have explicitly activated the preset settings in the "PRST" parameter.

---

1. Switch to the "Configuration" mode. To do this, press the  button for at least 5 seconds until the display shows the following:



2. Use the  button to change from linear actuator to part-turn actuator until the display shows the following:



- Call the "2.YAGL" parameter. To do this, briefly press the  button. This parameter has already been set to 90° automatically. The display shows the following:



- Call the "4.INITA" parameter. To do this, briefly press the  button. The display shows the following:



- Start the initialization process. To do this, press the  button for at least 5 seconds until the display shows the following:



The positioner runs through five initialization steps during the automatic initialization process. Displays for the initialization steps from "RUN1" to "RUN5" are shown in the lower line on the display. The initialization process depends on the actuator used, and takes up to 15 minutes.

- The following display indicates that the automatic initialization is complete. The total angle of rotation of the actuator is shown on the upper line on the display:

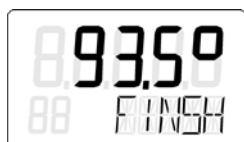

### Aborting the automatic initialization process

1. Press the  button. The display shows the following:



The positioner is in the "Configuration" mode.

2. Exit the "Configuration" mode. To do this, press the  button for at least 5 seconds.

The software status is displayed.

After releasing the  button, the positioner is in "P manual mode". The part-turn actuator is not initialized.

### See also

Sequence of automatic initialization (Page 115)

### 7.5.3 Manual initialization of part-turn actuators

You can use this function to initialize the positioner without needing to move the actuator to the end stops. The start and end positions of the actuator travel are set manually. When the control parameters are optimized, the further initialization process runs automatically.

### Requirements

The following requirements must be fulfilled before activating manual initialization:

1. The positioner has been prepared for using on part-turn actuators.
2. The actuator can be moved completely.
3. The displayed potentiometer position is within the permissible range between "P5.0" and "P95.0".

---

#### Note

##### Setting of the adjustment angle

The usual adjustment angle for part-turn actuators is 90°. Accordingly set the transmission ratio selector in the positioner to 90°.

---

### Initializing the positioner manually

1. Switch to the "Configuration" mode. To do this, press the  button for at least 5 seconds until the display shows the following:



2. Set the "YFCT" parameter to "turn". To do this, press . The display shows the following:



3. Call the second parameter "YAGL". To do this, press . The display shows the following:



4. Call the "INITM" parameter. To do this, press the  button twice. The display shows the following:





5. Start the initialization process. Press the  button for at least 5 seconds until the display shows the following:



6. The current potentiometer position is output on the display after 5 seconds:



7. Determine the end position 1 of the actuator.
8. Move the actuator to the desired position using the  or  button.

9. Press the  button. The current position of the actuator is applied. The display shows the following:











---

**Note**

**Fault message "RANGE"**



The selected end position is beyond the permissible measuring range if the "RANGE" message is output on the display. Correct the settings as follows:

1. Move the friction clutch until the display shows "OK".
  2. Press the  button.
  3. Move the actuator to another position using the  or  button.
  4. Abort the manual initialization process by pressing the  button.
  5. Then return to "P manual mode" mode.
  6. Correct the actuator travel and the position detection.
- 

10. Determine the end position 2 of the actuator. Move the actuator to the desired position using the  or  button.
11. Press the  button. The current position of the actuator is applied.
12. The initialization process is automatically resumed. Initialization steps "RUN1" to "RUN5" are output in the bottom line of the display. The following display indicates that the initialization has been completed successfully:



**Aborting the manual initialization process**

1. Press the  button. The display shows the "INITM" parameter. The positioner is in the "Configuration" mode.
2. Exit the "Configuration" mode. To do this, press the  button for at least 5 seconds.
3. The software status is displayed.
4. After releasing the  button, the positioner is in "P manual mode". "P manual mode" means that the positioner has not been initialized.



## See also

Overview of device components (Page 22)

## 7.6 Device replacement

### Introduction

---

#### Note

##### Initialization

The positioner can be replaced without having to interrupt ongoing processes. However, copying and pasting of the initialization parameters only allows an approximate adjustment of the positioner to your actuator. Following initialization, the positioner initially works with the manually defined parameters.

- For this reason, an automatic or manual initialization should be carried out as soon as possible.

---

#### Note

##### Deferred initialization

Initialize the new positioner as soon as possible. The following properties can be ensured only after initializing:

- Optimum adjustment of the positioner as per the mechanical and dynamic properties of the actuator.
- Non-deviating position of end stops
- Correctness of the maintenance data

---

There are two ways of replacing a positioner when the equipment is in operation, without having to interrupt the process. The two options depend on whether your positioner has communication.

### First possibility - with communication

1. Read the initialization parameters from the previous positioner. Use the parameter assignment tools suitable for this purpose.
2. Read the initialization parameters from Point 1 into the new positioner.
3. Fix the actuator at its current position mechanically or pneumatically. Use the locking function of your mounting kit, if available.
4. Determine the actual position value. To do this, read the actual position value from the display of the previous positioner. Note down the read value.
5. Dismount the previous positioner from the actuator.
6. Attach the lever arm of the previous positioner to the new positioner.
7. Mount the new positioner on the actuator.

8. Set the transmission ratio selector of the new positioner to the same position as that of the previous positioner.
9. If the displayed actual position value differs from the noted value, correct the deviation by moving the friction clutch.
10. The new positioner is ready for operation when the displayed and noted values match.
11. Release the fixing of the actuator.

### Second possibility - without communication

1. Fix the actuator at its current position mechanically or pneumatically. Use the locking function of your mounting kit, if available.
2. Determine the actual position value. To do this, read the actual position value on the display of the previous positioner. Note down the read value.

---

#### Note

##### Electronics defect

If the positioner's electronics is defective, measure the actual position value with a ruler or protractor at the actuator or valve. Convert the read value into %. Note down the converted value.

---

3. Dismount the previous positioner from the actuator.
4. Attach the lever arm of the previous positioner to the new positioner.
5. To prevent interference with the ongoing process, initialize the new positioner on an actuator with a similar stroke or swivel range. Attach the new positioner to this actuator. Initialize the new positioner.
6. Then dismount the new, initialized positioner from this actuator.
7. Mount the new, initialized positioner on the fixed actuator.
8. If the displayed actual position value differs from the noted value, correct the deviation by moving the friction clutch.
9. Use the buttons on the positioner to enter the parameters which deviate from the factory setting, such as type of actuator or tight closing.
10. Change to the measured value view using the mode button (manual button), see section "Description of operating modes (Page 106)".
11. Release the fixing of the actuator.

### See also

- Sequence of automatic initialization (Page 115)
- Automatic initialization of linear actuators (Page 122)
- Automatic initialization of part-turn actuators (Page 130)
- Manual initialization of linear actuators (Page 125)
- Manual initialization of part-turn actuators (Page 132)

# Functional safety

## 8.1 General Safety Notes

This chapter describes the functional safety in general and not specific to a device. The devices in the examples are selected as representative examples. The device-specific information follows in the next chapter.

### Description

The combination of transmitter, automation system and final controlling element forms a safety-instrumented system that performs a safety function.

### Functional principle of single-channel operation

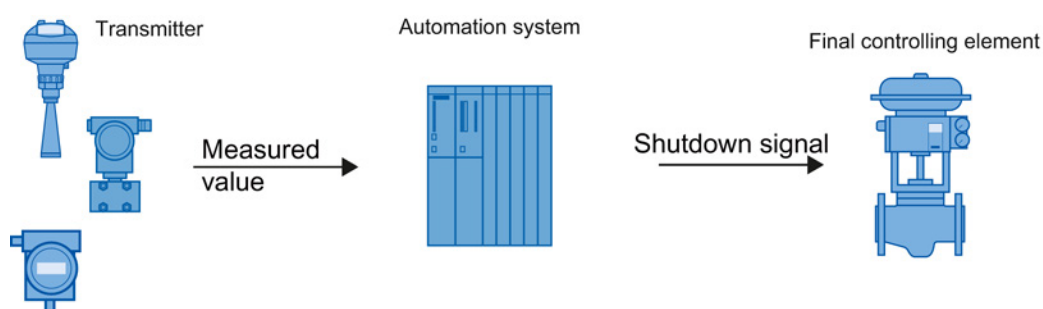

Figure 8-1 Safety-instrumented system for single-channel operation

The transmitter generates a process-related measured value that is transferred to the automation system. The automation system monitors this measured value. If the measured value exceeds the range of the high or low limit, the automation system generates a shutdown signal for the connected final controlling element, which switches the associated valve to the specified safety position.

### See also

Overview of diagnostics values (Page 197)

Meaning of the diagnostics values (Page 200)

### 8.1.1 Safety Integrity Level (SIL)

The international standard IEC 61508 defines four discrete Safety Integrity Levels (SIL) from SIL 1 to SIL 4. Every level corresponds to a probability range for the failure of a safety function.

#### Description

The following table shows the dependency of the SIL on the "average probability of dangerous failures of a safety function of the entire safety-instrumented system" (PFD<sub>AVG</sub>). The table deals with "Low demand mode", i.e. the safety function is required a maximum of once per year on average.

Table 8- 1 Safety Integrity Level

SIL	Interval
4	$10^{-5} \leq PFD_{AVG} < 10^{-4}$
3	$10^{-4} \leq PFD_{AVG} < 10^{-3}$
2	$10^{-3} \leq PFD_{AVG} < 10^{-2}$
1	$10^{-2} \leq PFD_{AVG} < 10^{-1}$

The "average probability of dangerous failures of the entire safety-instrumented system" (PFD<sub>AVG</sub>) is normally split between the following three components:

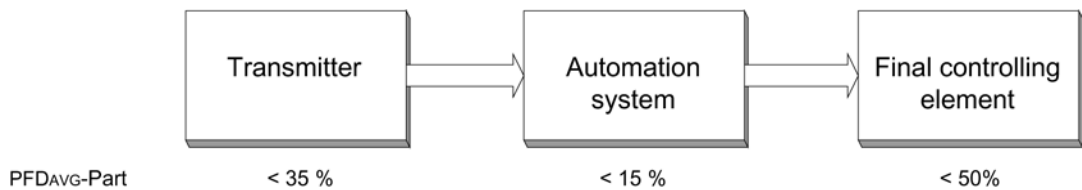

Figure 8-2 PFD distribution

The following table shows the achievable Safety Integrity Level (SIL) for the entire safety-instrumented system for type B devices depending on the safe failure fraction (SFF) and the hardware fault tolerance (HFT).

- Type B devices include analog transmitters and shut-off valves **with** complex components, e.g. microprocessors (also see IEC 61508, Section 2).
- For detailed information on values and hardware/firmware versions for your device, refer to the manufacturer declaration for the device (Declaration of Conformity, Functional Safety according to IEC 61508 and IEC 61511): Certificates (<http://www.siemens.com/processinstrumentation/certificates>).

SFF	HFT for type B devices		
	0	1 (0) <sup>1)</sup>	2 (1) <sup>1)</sup>
< 60 %	Not permitted	SIL 1	SIL 2
60 to 90 %	SIL 1	SIL 2	SIL 3
90 to 99 %	SIL 2	SIL 3	SIL 4
> 99 %	SIL 3	SIL 4	SIL 4

<sup>1)</sup> Operational reliability in accordance with IEC 61511-1, Section 11.4.4

### Operational reliability

According to IEC 61511-1, Section 11.4.4, the hardware fault tolerance (HFT) can be reduced by one (values in brackets) for transmitters and final controlling elements with complex components if the following conditions apply to the device:

- The device is proven in operation.
- The user can configure only the process-related parameters, e.g. control range, signal direction in case of a fault, limiting values, etc.
- The configuration level of the firmware is blocked against unauthorized operation.
- The function requires SIL of less than 4.

## 8.2 Device-specific safety instructions

### 8.2.1 Range of applications for functional safety

The positioner is suitable for use on valves that satisfy the special requirements in terms of functional safety up to SIL 2 in accordance with IEC 61508 or IEC 61511. The versions 6DR501., 6DR511., 6DR521., and 6DR531. are available for this purpose.

These are single-acting, depressurizing positioners with an input from 4 to 20 mA for installation on pneumatic actuators with spring reset.

The positioner automatically depressurizes the valve actuator on demand or in case of faults, which thus switches the valve to the specified safety position.

These positioners meet the following requirements:

- Functional safety up to SIL 2 in accordance with IEC 61508 or IEC 61511 for safe venting
- Explosion protection for the versions 6DR5...-E/D/F/G/K...
- Electromagnetic compatibility in accordance with EN 61326/A1, Appendix A.1

## 8.2.2 Safety function

### Safety function on positioner

Bleeding of the connected drive is the safety function for the SIPART PS2 positioner. The built-in spring brings the valve to the required safety position. Depending on the direction of action of this spring, the valve is completely opened or closed.

This safety function can be triggered by:

- Failure of electrical auxiliary power
- Falling below failure signal 3.6 mA at set current input ( $I_w$ ).

#### DANGER

##### Non-triggering of the safety function during a partial stroke test

If a partial stroke test is running, execution of the safety function is delayed by an input current less than 3.6 mA. This can lead to a malfunction of the process plant or application.

- Switch off the auxiliary electrical power if the safety function is to be triggered during a partial stroke test.

Situations in which it is not possible to bleed the drive on demand or in case of a fault represent a dangerous failure.

#### WARNING

##### Disregarding conditions for fulfilling the safety function

Disregard can result in a malfunction of the process plant or application, e.g. process pressure too high, maximum level exceeded.

The mandatory settings and conditions are listed in sections "Settings (Page 141)" and "Safety characteristics (Page 143)".

- These conditions must be adhered to in order to fulfill the safety function.

The characteristic service life of the valve block depends on the load. On average it is approx. 200 million switching operations for each of the two pilot valves with symmetrical load. The actual number of switching operations performed can be called in the local display or via HART communication.

### 8.2.3 Settings

After assembly and commissioning, the following parameter settings should be made for the safety function:

#### Safety parameters

Parameter name	Function	Set parameter value	Meaning
2.YAGL	Rated angle of rotation of the positioner shaft	33° or 90° to match the setting for the transmission ratio selector	Adaptation to the mechanically set range of stroke / rotation angle
6.SCUR	Current range of setpoint	4 MA	4...20 mA
7.SDIR	Setpoint direction	riSE	Rising - for actuators with safety position down/closed (valve closed)
		FALL	Falling - for actuators with safety position up/open (valve open)
12.SFCT	Setpoint function	Everything except "FrEE"	<ul style="list-style-type: none"> <li>• Linear</li> <li>• Equal percentage</li> <li>• Inverse equal percentage</li> </ul>
39.YCLS	Controller output tightening	do	Depressurizing - for actuators with safety position down/closed (valve closed)
		uP	Depressurizing - for actuators with safety position up/open (valve open)

#### Protection against configuration changes

After configuration, the SIPART PS2 positioner must be switched to automatic operation. You should then fit the enclosure cover so that the device is protected against unwanted and unauthorized changes/operation.

The SIPART PS2 positioner is fitted with an additional protective function to prevent configuration changes:

1. Configure the parameter 43.BIN1 = bLoc2.
2. Bridge terminals 9 and 10 of the binary input BE1.

In this condition, the "configuration" operating level using the keys and HART communication and manual operation are blocked.

### Checking the safety function

To check that the safety configuration is correct, apply a set current of 3.6 mA.  
In this condition, the drive must return the valve to the specified safety position.

### See also

Safety function (Page 140)

## 8.2.4 Behavior in case of faults

### Fault

The procedure in case of faults is described in section "Fault correction (Page 213)".

## 8.2.5 Maintenance/Checking

### Checking the function

We recommend that the functioning of the positioner or positioners is checked at regular intervals of one year.

Check at least the following:

1. Connect the set value of 4 mA.
  - Verify that the valve reaches the corresponding end position.
  - Check the locally displayed internal, digitized values for the setpoint and position.
2. Activate the 20 mA setpoint.
  - Verify that the valve reaches the corresponding end position.
  - Check the locally displayed internal, digitized values for the setpoint and position.



## Checking safety

Verify the safety function of the entire safety circuit on a regular basis in accordance with IEC 61508/61511. The test intervals are determined in the course of calculations for each safety circuit of a system ( $PFD_{AVG}$ ).

Execute at least the following tests on the positioner(s):

1. Connect the set value of 3.6 mA.
  - Verify that the valve returns to the safety position.
2. Activate the 20 mA setpoint.
  - Reduce the inlet pressure ( $P_z$ ) to a third of the maximum supply pressure
  - Verify that the valve returns to the safety position.
3. Check the degree of soiling of the screens in the pneumatic fittings. Clean the screens if necessary.

## 8.2.6 Safety characteristics

The safety characteristics necessary for use of the system are listed in the SIL declaration of conformity. These values apply under the following conditions:

- The positioner is only used in applications with low demand rate for the "Low demand mode".
- Communication with the HART protocol is only used for:
  - Device configuration
  - Reading diagnostics values
  - However, it is not used for operations critical to safety. In particular, the trace function must not be activated in safety related operation. The setpoint  $w$  must not be applied via HART; it is connected via the setpoint current input on the positioner.
- The safety-related parameters/settings (see the chapter "Settings (Page 141)") have been entered by local operation or via HART communication and checked on the local display prior to safety-related operation.
- The positioner is blocked against unwanted and unauthorized changes/operation.
- The 4 to 20 mA input signal for the SIPART PS2 positioner is generated by a safe system that fulfills SIL 2 for single-channel operation.
- The connected single-action type drive returns the valve to the safe end position by spring force in the following scenarios:
  - Pressure failure
  - At a chamber pressure (Y1 connection) up to a third of the maximum available intake pressure ( $P_z$  connection)
- The air outlet does not contain any additional cross-sectional contractions leading to an increased dynamic pressure. In particular, a silencer is only allowed if icing or other contamination is ruled out.
- The restrictor in the Y1 circuit may not be completely closed during operation.

- The auxiliary pneumatic power is free of oil, water and dirt in line with:  
DIN/ISO 8573-1, maximum class 2
- The average temperature viewed over a long period is 40 °C.
- The MTTR after a device fault is 8 hours.
- In case of a fault, the pneumatic outlet of the positioner is depressurized. A spring in the pneumatic actuator must move the valve to the pre-defined, safe end position.
- A dangerous failure of the positioner is a failure where the pressure outlet is not depressurized, or the safety position is not reached, when the input current < 3.6 mA.
- The safety function is only triggered during a partial stroke test if auxiliary electrical power is switched off. The safety function is not triggered by an input current less than 3.6 mA. The partial stroke test is available as of firmware version 4.00.00.

## Parameterizing/addressing

### 9.1 Parameter chapter

In this chapter, how the parameters work is explained in the form of a configuration schematic. Afterwards, there is a tabular overview of all parameters. Finally, the individual parameters and their functionality are described.

## 9.2 Configuration schematic for parameter operating principle

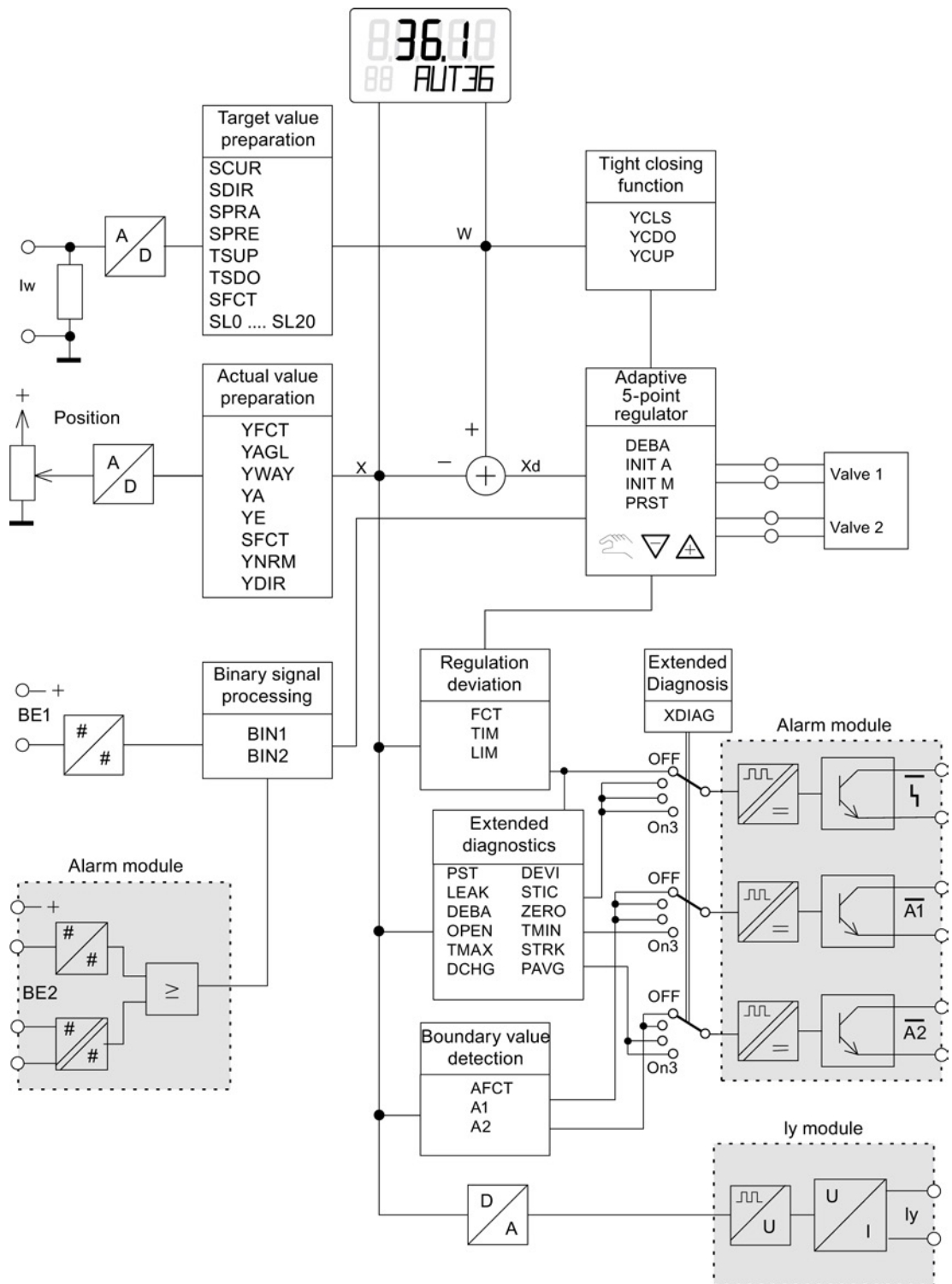

Figure 9-1 Configuration block schematic

## 9.3 Overview of parameters

### 9.3.1 Overview of parameters 1 to 5

#### Introduction

Parameters 1 to 5 are the same for all versions of positioner. These parameters are used to adjust the positioner to the actuator. Normally the parameter setup is sufficient to be able to operate the positioner on an actuator.

If you want to get to know the positioner in detail, gradually try out the effects of the remaining parameters by systematic testing

#### Note

Factory-set parameter values are printed in bold in the following table.

#### Overview

Parameter	Function	Parameter values	Unit
1.YFCT	Type of position actuator	turn (part-turn actuator)	
		<b>WAY</b> (linear actuator)	
		LWAY (linear actuator without sine correction)	
		ncSt (part-turn actuator with NCS)	
		-ncSt (part-turn actuator with NCS, inverse direction of action)	
		ncSL (linear actuator with NCS)	
		ncSLL (linear actuator with NCS and lever)	
2.YAGL	Nominal angle of rotation of the feedback message <sup>1)</sup>	<b>33°</b>	Degrees
		90°	
3.YWAY <sup>2)</sup>	Range of stroke (optional setting) <sup>3)</sup>	<b>OFF</b>	mm
		5   10   15   20 (Short lever 33°)	
		25   30   35 (Short lever 90°)	
		40   50   60   70   90   110   130 (Long lever 90°)	
4.INITA	Initialization (automatic)	<b>NOINI</b>   no / ###.#   Strt	
5.INITM	Initialization (manual)	<b>NOINI</b>   no / ###.#   Strt	

9.3 Overview of parameters

- 1) Set the transmission ratio selector accordingly.
- 2) The parameter only appears for "WAY" and for "ncSLL".
- 3) When used the value must correspond with the set range of stroke on the actuator.  
Carriers must be scaled to the actuator's stroke value, or if this is not scaled they then must be set to the next largest scaled value.

9.3.2 Overview of parameters 6 to 51

Introduction

These parameters are used to configure the following additional functions of the positioner:

- Target value preparation
- Actual value preparation
- Binary signal processing
- Tight closing function
- Boundary value detection

**Note**

Factory-set parameter values are printed in bold in the following table.

Overview

Parameter	Function	Parameter values	Unit
6.SCUR	Current range of setpoint		
		0 ... 20 mA	0 MA
		4 ... 20 mA	<b>4 MA</b>
7.SDIR	Setpoint setup		
		Rising	<b>riSE</b>
		Falling	FALL
8.SPRA	Setpoint split range start	<b>0.0</b> ... 100.0	%
9.SPRE	Setpoint split range end	0.0 ... <b>100.0</b>	%
10.TSUP	Setpoint ramp OPEN	Auto / <b>0</b> ... 400	s
11.TSDO	Setpoint ramp CLOSED	<b>0</b> ... 400	s
12.SFCT	Setpoint function		
		Linear	<b>Lin</b>
	Equal percentage	1 : 25	1 - 25
		1 : 33	1 - 33
		1 : 50	1 - 50
Inverse equal percentage	25 : 1	n1 - 25	

Parameter	Function		Parameter values	Unit
			33 : 1	n1 - 33
			50 : 1	n1 - 50
		Freely adjustable		FrEE
13.SL0 ... 33.SL20 1)	Setpoint turning point			
13.SL0	In	0 %	0.0 ... 100.0	
14.SL1 ....		5 % ...		
32.SL19		95 %		
33.SL20		100 %		
34.DEBA	Deadband of closed-loop controller		<b>Auto</b> / 0.1 ... 10.0	%
35.YA	Start of the manipulated variable limit		<b>0.0</b> ... 100.0	%
36.YE	End of the manipulated variable limit		0.0 ... <b>100.0</b>	%
37.YNRM	Manipulated variable scaling			
		Mechanical	<b>MPOS</b>	
		On flow	FLOW	
38.YDIR	Manipulated variable direction of action for display and position feedback			
		Rising	<b>riSE</b>	
		Falling	FALL	
39.YCLS	Manipulated variable tight closing			
		None	<b>no</b>	
		Top only	uP	
		Bottom only	do	
		Top and bottom	uP do	
40.YCDO	Lower value for tight closing		0.0 ... <b>0.5</b> ... 100 %	%
41.YCUP	Upper value for tight closing		0.0 ... <b>99.5</b> ... 100 %	%
42.BIN1 2)	Function of BE1		Normally open	Normally closed
		None	<b>OFF</b>	
		Message only	on	-on
		Block configuration	bloc1	
		Block configuration and manual	bloc2	
		Move valve to position YE	uP	-uP
		Move valve to position YA	doWn	-doWn
		Block movement	StoP	-StoP
		Partial-Stroke-Test	PST	-PST
43.BIN2 2)	Function of BE2		Normally open	Normally closed
		None	<b>OFF</b>	
		Message only	on	-on
		Move valve to position YE	uP	-uP
		Move valve to position YA	doWn	-doWn
		Block movement	StoP	-StoP
		Partial-Stroke-Test	PST	-PST

Parameter	Function		Parameter values		Unit
			Normal	Inverted	
44.AFCT 3)	Alarm function		Normal	Inverted	
		None	OFF		
		A1 = Min, A2 = Max	▯▯▯▯▯▯	▯▯▯▯▯▯	
		A1 = Min, A2 = Min	▯▯▯▯▯▯	▯▯▯▯▯▯	
	A1 = Max, A2 = Max	▯▯▯▯▯▯	▯▯▯▯▯▯		
45.A1	Trigger threshold, alarm 1		0.0 ... 10.0 ... 100 %		%
46.A2	Trigger threshold, alarm 2		0.0 ... 90.0 ... 100 %		%
47. 4FCT 3)	Function for fault message output		Normal	Inverted	
		Fault	▯▯▯▯▯▯	▯▯▯▯▯▯	
		Fault + not automatic <sup>4)</sup>	▯▯▯▯▯▯	▯▯▯▯▯▯	
	Fault + not automatic + BE <sup>4)</sup>	▯▯▯▯▯▯	▯▯▯▯▯▯		
48. 4TIM	Monitoring time for setting of fault message "regulation deviation"		Auto / 0 ... 100		s
49. 4LIM	Response threshold for fault message "regulation deviation"		Auto / 0 ... 100		%
50.PRST	Preset (factory setting) <sup>5)</sup>				
	no	Nothing activated	no		
	Strt	Start of factory setting	Strt		
	oCAY	Display after pushing button for 5 sec	oCAY		
51.XDIAG	Activation of extended diagnostics				
		Off	OFF		
		Single-level message	On1		
		Two-level message	On2		
	Three-level message	On3			

- 1) Setpoint turning points only appear when "12.SFCT = FrEE" is selected.
- 2) "Normally closed" means: Action on switch open or Low level  
"Normally open" means: Action on switch closed or High level
- 3) "Normal" means: High level, no fault message  
"Inverse" means: Low level, no fault message
- 4) "+" means: Logical OR combination
- 5) Preset results in "NOINI"!



### 9.3.3 Overview parameters A to P

#### Introduction

These parameters are used to set the extended diagnostic functions of the positioner.

#### Note

##### Factory setting

Factory-set parameter values are printed in bold in the following table.

#### Note

##### Display

Parameters A to P and their sub-parameters are only displayed when the extended diagnostics has been activated using parameter "XDIAG" with parameter value "On1", "On2" or "On3".

#### Overview parameter A

Parameter	Function	Parameter values	Unit
A.4PST	Partial stroke test with the following parameters:		
A1.STPOS	Starting position	0.0 ... <b>100.0</b>	%
A2.STTOL	Starting tolerance	0.1 ... <b>2.0</b> ... 10.0	%
A3.STEP	Stroke magnitude	0.1 ... <b>10.0</b> ... 100.0	%
A4.STEPD	Stroke direction	uP / <b>do</b> / uP do	
A5.INTRV	Test interval	<b>OFF</b> / 1 ... 365	Days
A6.PSTIN	Reference stroke time for partial stroke test	<b>NOINI</b> / (C)### / Fdini / rEAL	s
A7.FACT1	Factor 1	0.1 ... <b>1.5</b> ... 100.0	
A8.FACT2	Factor 2	0.1 ... <b>3.0</b> ... 100.0	
A9.FACT3	Factor 3	0.1 ... <b>5.0</b> ... 100.0	

#### Overview parameter b

Parameter	Function	Parameter values	Unit
b.4DEVI	General control valve fault with the following parameters:		
b1.TIM	Time constant	<b>Auto</b> / 1 ... 400	s
b2.LIMIT	Limit	0.1 ... <b>1.0</b> ... 100.0	%
b3.FACT1	Factor 1	0.1 ... <b>5.0</b> ... 100.0	
b4.FACT2	Factor 2	0.1 ... <b>10.0</b> ... 100.0	
b5.FACT3	Factor 3	0.1 ... <b>15.0</b> ... 100.0	

**Overview parameter C**

Parameter	Function	Parameter values	Unit
C.↵LEAK	Pneumatic leakage with the following parameters:		
C1.LIMIT	Limit	0.1 ... <b>30.0</b> ... 100.0	%
C2.FACT1	Factor 1	0.1 ... <b>1.0</b> ... 100.0	
C3.FACT2	Factor 2	0.1 ... <b>1.5</b> ... 100.0	
C4.FACT3	Factor 3	0.1 ... <b>2.0</b> ... 100.0	

**Overview parameter d**

Parameter	Function	Parameter values	Unit
d.↵STIC	Friction (slip-stick effect) with the following parameters:		
d1.LIMIT	Limit	0.1 ... <b>1.0</b> ... 100.0	%
d2.FACT1	Factor 1	0.1 ... <b>2.0</b> ... 100.0	
d3.FACT2	Factor 2	0.1 ... <b>5.0</b> ... 100.0	
d4.FACT3	Factor 3	0.1 ... <b>10.0</b> ... 100.0	

**Overview parameter E**

Parameter	Function	Parameter values	Unit
E.↵DEBA	Deadband monitoring with the following parameters:		
E1.LEVL3	Threshold	0.1 ... <b>2.0</b> ... 10.0	%

**Overview parameter F**

Parameter	Function	Parameter values	Unit
F.↵ZERO	Zero point monitoring with the following parameters:		
F1.LEVL1	Threshold 1	0.1 ... <b>1.0</b> ... 10.0	%
F2.LEVL2	Threshold 2	0.1 ... <b>2.0</b> ... 10.0	
F3.LEVL3	Threshold 3	0.1 ... <b>4.0</b> ... 10.0	

**Overview parameter G**

Parameter	Function	Parameter values	Unit
G.↵OPEN	Displacement of the upper stop with the following parameters:		
G1.LEVL1	Threshold 1	0.1 ... <b>1.0</b> ... 10.0	%
G2.LEVL2	Threshold 2	0.1 ... <b>2.0</b> ... 10.0	
G3.LEVL3	Threshold 3	0.1 ... <b>4.0</b> ... 10.0	

## Overview parameter H

Parameter	Function	Parameter values		Unit
H.½TMIN	Monitoring of the lower limit temperature with the following parameters:			
H1.TUNIT	Temperature unit	°C	°F	°C/°F
H2.LEVL1	Threshold 1	-40 ... <b>-25</b> ... 90	-40 ... 194	
H3.LEVL2	Threshold 2	-40 ... <b>-30</b> ... 90	-40 ... 194	
H4.LEVL3	Threshold 3	<b>-40</b> ... 90	-40 ... 194	

## Overview parameter J

Parameter	Function	Parameter values		Unit
J.½TMAX	Monitoring of the upper limit temperature with the following parameters:			
J1.TUNIT	Temperature unit	°C	°F	°C/°F
J2.LEVL1	Threshold 1	-40 ... <b>75</b> ... 90	-40 ... 194	
J3.LEVL2	Threshold 2	-40 ... <b>80</b> ... 90	-40 ... 194	
J4.LEVL3	Threshold 3	-40 ... <b>90</b>	-40 ... 194	

## Overview parameter L

Parameter	Function	Parameter values		Unit
L.½STRK	Monitoring the path integral with the following parameters:			
L1.LIMIT	Limit for the number of changes of direction	1 ... <b>1E6</b> ... 1E8		
L2.FACT1	Factor 1	0.1 ... <b>1.0</b> ... 40.0		
L3.FACT2	Factor 2	0.1 ... <b>2.0</b> ... 40.0		
L4.FACT3	Factor 3	0.1 ... <b>5.0</b> ... 40.0		

## Overview parameter O

Parameter	Function	Parameter values		Unit
O.½DCHG	Monitoring the changes in direction with the following parameters:			
O1.LIMIT	Limit for the number of changes of direction	1 ... <b>1E6</b> ... 1E8		
O2.FACT1	Factor 1	0.1 ... <b>1.0</b> ... 40.0		
O3.FACT2	Factor 2	0.1 ... <b>2.0</b> ... 40.0		
O4.FACT3	Factor 3	0.1 ... <b>5.0</b> ... 40.0		

Overview parameter P

Parameter	Function	Parameter values	Unit
P.↳PAVG	Position mean value calculation with the following parameters:		
P1.TBASE	Time base of the mean value generation	<b>0.5h</b> / 8h / 5d / 60d / 2.5y	
P2.STATE	State of the position mean value calculation	<b>IdLE</b> / rEF / ###.# / Strt	
P3.LEVL1	Threshold 1	0.1 ... <b>2.0</b> ... 100.0	%
P4.LEVL2	Threshold 2	0.1 ... <b>5.0</b> ... 100.0	%
P5.LEVL3	Threshold 3	0.1 ... <b>10.0</b> ... 100.0	%

## 9.4 Description of parameters

### 9.4.1 Description of parameters 1 through 5

#### 1.YFCT - actuator type

You can use this parameter to adjust the positioner as per the respective actuator and, if required, as per the position sensor used. The following parameter values are available:

- YFCT = turn

Use this parameter value for a part-turn actuator.

The subsequent parameter "2.YAGL" is automatically set to 90° and cannot be changed.

- YFCT = WAY (factory setting)

Use this parameter value for a linear actuator. The positioner compensates the non-linearity caused due to the transformation of the linear movement of the linear actuator into the rotary movement of the positioner shaft. For this purpose, the positioner is set in the factory such that it displays values between "P49.0" and "P51.0" when the lever on the positioner shaft is perpendicular to the linear actuator spindle.

- YFCT = LWAY

Use this parameter value for:

- An external linear potentiometer on a linear actuator.
- An external linear potentiometer on a part-turn actuator with a reverse direction of action.

- YFCT = ncSt

Use this parameter value when you use a non contacting sensor on a part-turn actuator.

- YFCT = -ncSt

Use this parameter value when you use a non contacting sensor on a part-turn actuator with a reverse direction of action.

- YFCT = ncSL

Use this parameter value when you use a non contacting sensor on a linear actuator.

- YFCT = ncSLL

Use this parameter value when you use a non contacting sensor on a linear actuator for which the position is transformed by a lever into a rotary movement.

---

#### **Note**

The "3.YWAY" parameter is displayed only for "WAY" and "ncSLL".

---

The factory setting is "WAY".

## 2.YAGL - angle of rotation of the feedback shaft

Use this parameter for a linear actuator. For a linear actuator, set an angle of 33° or 90° depending on the range of stroke. The following is applicable:

- 33° for strokes ≤ 20 m
- 90° for strokes > 20 m

Both angles are possible if the lever up to 35 mm stroke is used. The long lever with a stroke greater than 35 mm is intended for an angle of 90°. The long lever is not part of the mounting kit 6DR4004-8V. Order the long lever separately using order number 6DR4004-8L.

The "YFCT = turn" parameter value sets an angle of 90° automatically for part-turn actuators.

---

### Note

#### Matching the angles

Ensure that the values set in the transmission ratio selector and the "2.YAGL" parameter match. If not, the value shown on the display does not match the actual position.

---

The factory setting is "33°".

## See also

Overview of device components (Page 22)

## 3.YWAY - display of the range of stroke

Use this parameter to set the value for the real range of stroke. This parameter is optional. You must set this parameter only if the determined value in mm is to be displayed at the end of the initialization process of a linear actuator.

Determine the value for the range of stroke as follows:

Fix the carrier pin on the lever at the desired position. This position on the lever has a specific scaled value, e.g. 25. Set this scaled value in the "YWAY" parameter.

If you select the "OFF" parameter value, the real stroke is not displayed after initialization.

---

### Note

The value set in the "YWAY" parameter must match with the mechanical range of stroke. Set the carrier to the value of the actuator stroke. If the actuator stroke is not scaled, set it to the next higher scaled value.

---

The factory setting is "OFF".

## 4.INITA - automatic initialization

Use this parameter to start the automatic initialization process. Select the "Strt" parameter value. Then press the  button for at least 5 seconds. The sequence of the initialization process from "RUN1" to "RUN5" is output in the bottom line of the display.

The factory setting is "NOINI".

### 5.INITM - manual initialization

Use this parameter to start the manual initialization process. Select the "Strt" parameter value. Then press the  $\triangle$  button for at least 5 seconds.

---

#### Note

If the positioner has already been initialized and if the "INITA" and "INITM" values are set, it is possible to reset the positioner to the non-initialized status. To do this, press the  $\nabla$  button for at least 5 seconds.

---

The factory setting is "NOINI".

### See also

Commissioning (Page 111)

Sequence of automatic initialization (Page 115)

Manual initialization of linear actuators (Page 125)

Manual initialization of part-turn actuators (Page 132)

## 9.4.2 Description of parameters 6 through 51

### 9.4.2.1 Description of parameters 6

### 6.SCUR - Current range of setpoint

This parameter is used to set the current range of the setpoint. The selection of the current range depends on the type of connection. Parameter value "0 MA" (0 to 20 mA) is only possible for three-wire and four-wire connections.

The factory setting is "4 MA".

### See also

Basic device without Ex protection / in flameproof enclosure "Ex d" (Page 74)

Description of parameters 8 and 9 (Page 159)

### **9.4.2.2 Description of parameters 7**

#### **7.SDIR - Setpoint direction**

This parameter is used to set the setpoint direction. The setpoint direction is used to reverse the direction of action of the setpoint. The setpoint direction is primarily used for single-acting actuators with the safety setting "up".

The factory setting is "riSE".

#### **See also**

Description of parameters 8 and 9 (Page 159)



### 9.4.2.3 Description of parameters 8 and 9

#### 8.SPRA - Split range start

The factory setting is "0".  
and

#### 9.SPRE - Split range end

With these two parameters in combination with parameter "7.SDIR", you can limit the effective setpoint. This allows split range tasks with the following characteristic curves to be solved:

- rising/falling
- falling/rising
- falling/falling
- rising/rising

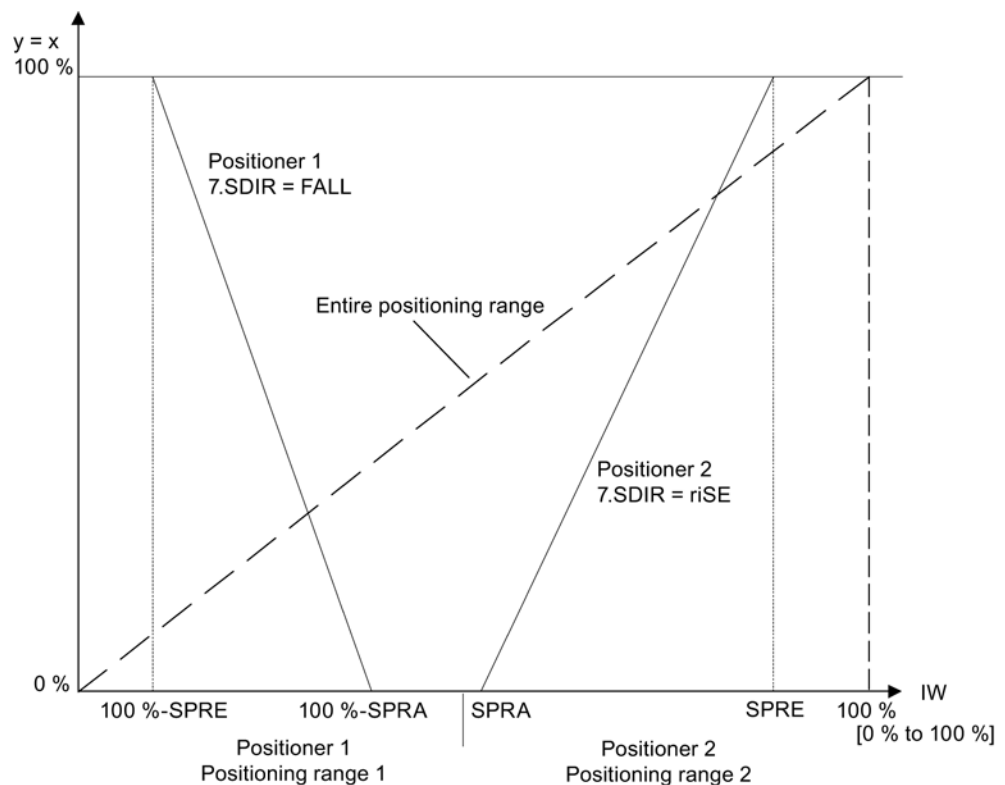

Figure 9-2 Example: Split range operation with two positioners

The factory setting is "100".

9.4.2.4 Description of parameters 10 and 11

10.TSUP - Setpoint ramp OPEN

and

11.TSDO - Setpoint ramp CLOSED

The setpoint ramp is effective in automatic mode and limits the speed of change of the effective setpoint. When switching from manual to automatic mode, the setpoint ramp is used to adjust the effective setpoint to the setpoint occupied by the positioner.

This smooth switching from manual to automatic mode prevents pressure excess in long pipelines.

The parameter value "TSUP = Auto" means the slower of the two actuating times determined during initialization is used for the setpoint ramp. Parameter value "TSDO" then has no effect.

The factory setting is "0".

9.4.2.5 Description of parameters 12

12.SFCT - Setpoint function

This parameter is used to linearize nonlinear valve characteristics. For linear valve characteristics, arbitrary flow characteristics are formed.

See figure in Description of parameters 13 through 33 (Page 161).

Seven valve characteristics are stored in the positioner and are selected using the "SFCT" parameter:

Valve characteristics		Set with parameter value
Linear		Lin
Equal percentage	1:25	1-25
Equal percentage	1:33	1-33
Equal percentage	1:50	1-50
Inverse equal percentage	25:1	n1-25
Inverse equal percentage	33:1	n1-33
Inverse equal percentage	50:1	n1-50
Freely adjustable		FrEE

The factory setting is "Lin".

### 9.4.2.6 Description of parameters 13 through 33

#### 13.SL0 bis 33.SL20 - Setpoint interpolation points

These parameters are used to assign a flow coefficient in units of 5% to each setpoint interpolation point. The setpoint interpolation points form a polygonal curve with 20 linear segments, which models the valve characteristic:

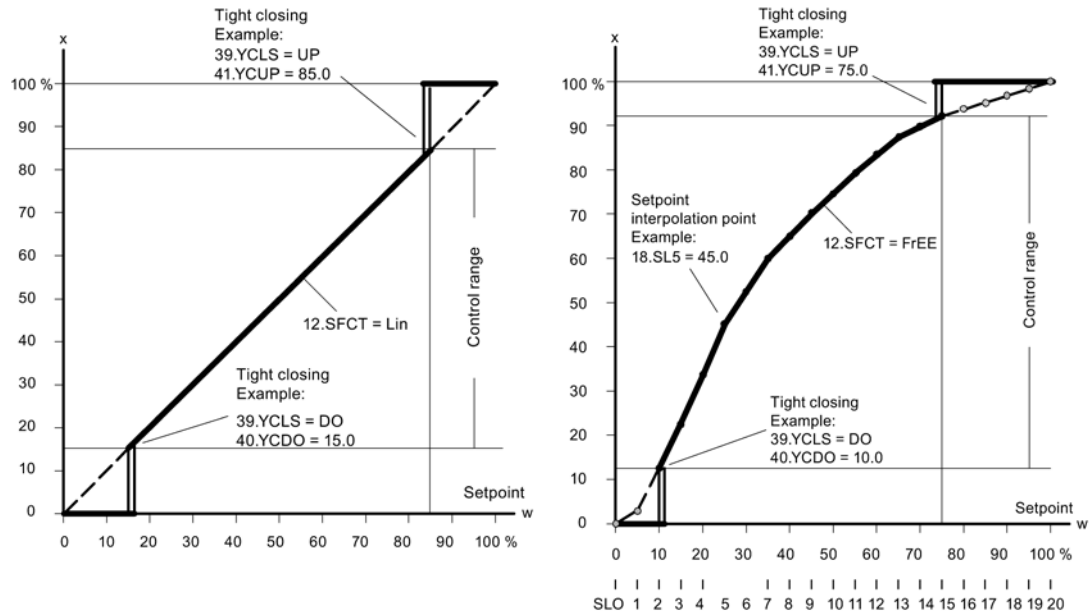

Setpoint characteristic curves, standardization of manipulated variables, and tight closing function

Input of the setpoint interpolation points is only possible for setting "12.SFCT = FrEE". You can only enter one monotone rising characteristic curve and two consecutive interpolation points must differ by at least 0.2%.

The factory setting is "0", "5" ... "95", "100".

#### See also

Description of parameters 12 (Page 160)

### 9.4.2.7 Description of parameters 34

#### 34.DEBA - Deadband of closed-loop controller

This parameter is used with value "Auto" to adjust the deadband in automatic mode continually and adaptively to the requirements of the control loop. If a regulator oscillation is detected, then the deadband is incrementally enlarged. The reverse adaptation takes place using a time criterion.

In the other discrete settings, the fixed value for the deadband is edited.

9.4 Description of parameters

The factory setting is "Auto".

**9.4.2.8 Description of parameters 35 and 36**

**35.YA - Start of the manipulated variable limit**

The factory setting is "0".

and

**36.YE - End of the manipulated variable limit**

These parameters are used to limit the mechanical actuator travel from stop to stop to the configured values. This allows the mechanical positioning range of the actuator to be limited to the effective flow, preventing integral saturation of the controlling closed-loop controller.

See figure in Description of parameters 37 (Page 162).

---

**Note**

"YE" must always be set larger than "YA".

---

The factory setting is "100".

**9.4.2.9 Description of parameters 37**

**YNRM - Normalization of manipulated variable**

Using the "YA" and "YE" parameters, you can limit the manipulated variable. This limitation causes two different scaling types, MPOS or FLOW, for the display and for the position feedback through the current output. See the figure below.

The MPOS scaling type shows the mechanical position from 0 to 100% between the hard stops of the initialization. The position is not influenced by the "YA" or "YE" parameters. The parameters "YA" and "YE" are shown in the MPOS scale.

The FLOW scale is the standardization from 0 to 100% in the range between the "YA" and "YE" parameters. Over this range, the setpoint  $w$  is also always 0 to 100%. This results in a more or less flow-proportional display and position feedback "I<sub>v</sub>". The flow-proportional display and position feedback "I<sub>v</sub>" also results from the use of valve characteristics.

In order to calculate the control deviation, the setpoint in the display is also shown in the corresponding scale.

The following uses the example of an 80-mm linear actuator to illustrate the dependence of the stroke on the scaling as well as the parameters "YA" and "YE".

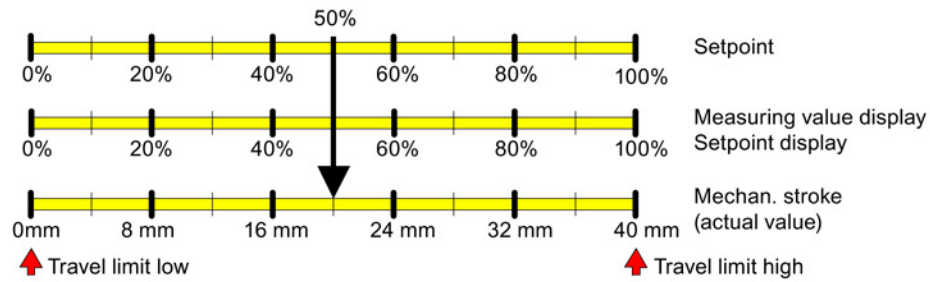

Figure 9-3 YNRM = MPOS or YNRM = FLOW; default: YA = 0 % and YE = 100 %

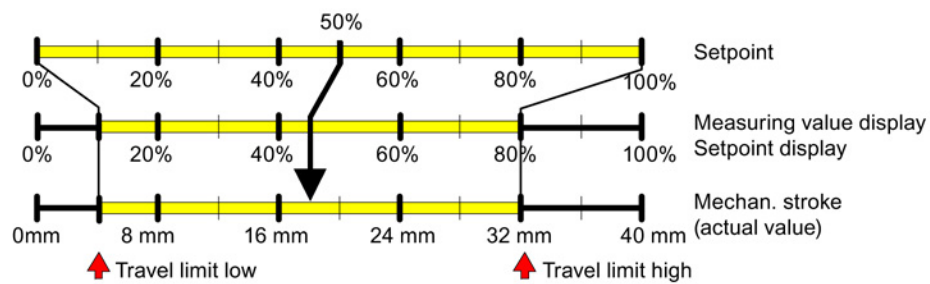

Figure 9-4 Example: YNRM = MPOS with YA = 10 % and YE = 80 %

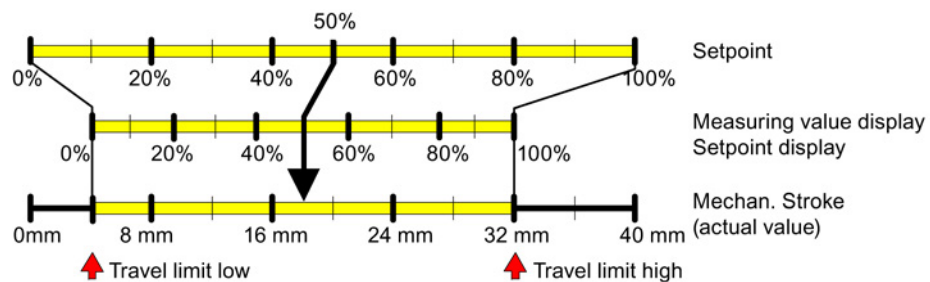

Figure 9-5 Example: YNRM = FLOW with YA = 10 % and YE = 80 %

The factory setting is "MPOS".

### See also

Description of parameters 35 and 36 (Page 162)

Description of parameters 39 (Page 164)

### 9.4.2.10 Description of parameters 38

#### 38.YDIR - Direction of manipulated variable for display

This parameter is used to set the direction of action of the display and the position feedback ly. The direction can be rising or falling.

The factory setting is "riSE".

### 9.4.2.11 Description of parameters 39

#### 39.YCLS - Manipulated variable tight closing

This parameter is used to move the valve into its seat with the maximum force of the actuator (permanent contact of the piezo valves). The tight closing function is activated on one side or for both end positions. The parameter "39.YCLS" becomes effective if the effective setpoint is below the parameter "40.YCDO" or above the parameter "41.YCUP".

See figure in Description of parameters 37 (Page 162) and figure in Description of parameters 13 through 33 (Page 161).

---

#### Note

##### Activated tight closing function

If the tight closing function is activated, then for parameter "49.└ LIM" the monitoring of regulation deviation is turned off in the appropriate overflow direction. Here, "YCDO: < 0 %" and "YCUP: > 100 %" apply. This functionality is especially advantageous for valves with soft seats. For a long-term monitoring of the end stop positions, we recommend activating the parameters "F.└ ZERO" and G.└ OPEN".

---

The factory setting is "no".

#### 9.4.2.12 Description of parameters 40 and 41

##### 40.YCDO - Lower value for tight closing

The factory setting is "0.5".  
and

##### 41.YCUP - Value for "tight closing above"

This parameter is used to set the value for "Tight closing below" and "Tight closing above".

---

##### **Note**

The value in the "40.YCDO" parameter must always be less than that in "41.YCUP". The tight closing function has a fixed hysteresis of 1%. The parameters "40.YCDO" and "41.YCUP" are relative to the mechanical stops. Both parameters are independent of the values set in the "7.SDIR" and "38.YDIR" parameters.

---

The factory setting is "99.5".

#### 9.4.2.13 Description of parameters 42 and 43

##### 42.BIN1 - Function binary input 1

and

##### 43.BIN2 - Function binary input 2

These parameters determine the function of the binary inputs. The possible functions are described below. The direction of action can be adapted to a normally closed or normally open mode.

- BIN1 or BIN2 = On or -On

Binary messages from peripherals, e.g. from pressure or temperature switches, can be read over the communication interface or fed through a logical OR combination with other messages to trigger the fault message output.

- BIN1 = bLoc1

With this parameter value, you can lock the "configuration" operation mode against reconfiguration. The lock is performed e.g. with a jumper between terminals 9 and 10.

- BIN1 = bLoc2

If binary input 1 is activated, then manual mode is also blocked in addition to the configuration operation mode.

- BIN1 or BIN2 = uP or doWn Contact closes or -uP or -doWn Contact opens.

If the binary input is activated in automatic mode, the actuator regulates to the value specified by the parameters "35.YA" and "36.YE".

9.4 Description of parameters

- BIN1 or BIN2 Contact closes = StoP or -StoP Contact opens.  
If the binary input is activated in automatic mode, the piezo valves are blocked. The actuator remains at the last position. Leakage measurements can be performed in this way without using the initialization function.
  - BIN1 or BIN2 = PSt or -PSt  
Using binary inputs 1 or 2, a partial-stroke test can be triggered by actuation of your choice of a normally closed or normally open switch.
  - BIN1 or BIN2 = OFF (factory setting)  
No function  
Special function of binary input 1: If binary input 1 is activated in "P-manual mode" by means of a jumper between terminals 9 and 10, then when the mode button is pushed the firmware version will be displayed.
- If one of the above functions is activated with the "BIN1" and "BIN2" parameters simultaneously, then: "Blocking" has priority over "uP" and "uP" has priority over "down".

9.4.2.14 Description of parameters 44

44.AFCT - Alarm function

This parameter can be used to determine the value at which going above or below a given offset or angle will result in a message. The triggering of alarms (limits) is relative to the MPOS scale. Alarms are signaled through the alarm module. In addition, alarms can also be read out over the HART communicator (optional).

The direction of action of the binary outputs can be adjusted from "High active" to "Low active" for the next system.

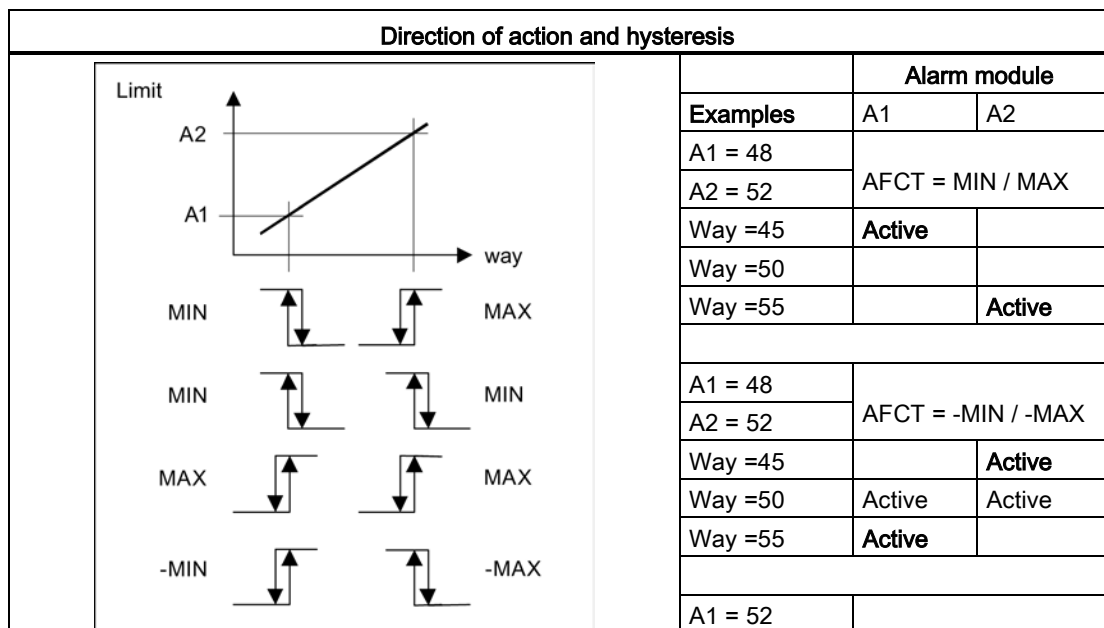



Direction of action and hysteresis			
	A2 = 48	AFCT = MIN / MAX	
	Way =45	<b>Active</b>	
	Way =50	Active	Active
	Way =55		<b>Active</b>
	A1 = 52	AFCT = -MIN / -MAX	
	A2 = 48		
	Way =45		<b>Active</b>
	Way =50		
	Way =55	<b>Active</b>	

**Note**

If the extended diagnostic is activated using parameter "51.XDIAG" with setting "On2" or "On3", then the alarms will not be output through the alarm module. Notification through HART communication is possible at any time, however.

**See also**

Description of parameters 51 (Page 170)

**9.4.2.15 Description of parameters 45 and 46**

**45.A1 - Trigger threshold, alarm 1**

and

**46.A2 - Trigger threshold, alarm 2**

These parameters are used to specify when an alarm should be displayed. The response thresholds of the alarms "45.A1" and "46.A2" are relative to the MPOS scale, which corresponds to the mechanical way.

### 9.4.2.16 Description of parameters 47

#### 47.4FCT - Fault message function

The fault message in the form of monitoring of control deviation over time can also be triggered due to the following events:

- Power failure
- Processor fault
- Actuator fault
- Valve fault
- Compressed air failure
- Threshold 3 error message in advanced diagnostics

See Description of parameters 51 (Page 170), 51.XDIAG activation of advanced diagnostics.

Note that the fault message cannot be switched off. It can however be suppressed (factory setting) when you switch over to "No automatic mode". If you want to generate a fault message here too, you must the parameter "47.4FCT" to "4nA".

You also have an option to "or" the fault message with the status of the binary inputs. To do this, set the "47.4FCT" parameter to "4nAb".

Select the setting "-4" if you want to output the fault message inverted to the alarm or SIA unit.

The factory setting is "4".

#### 9.4.2.17 Description of parameters 48

##### 48.4TIM - Monitoring time for setting of fault messages

This parameter is used to set the time in seconds within which the positioner must have reached the regulated condition. The corresponding response threshold is specified in the "49.4LIM" parameter.

When the configured time is exceeded, the fault message output is set.

---

##### Note

##### Activated tight closing function

If the tight closing function is activated, then for parameter "49.4LIM" the monitoring of regulation deviation is turned off in the appropriate overflow direction. Here, "YCDO: < 0 %" and "YCUP: > 100 %" apply. This functionality is especially advantageous for valves with soft seats. For a long-term monitoring of the end stop positions, we recommend activating the parameters "F.4ZERO" and "G.4OPEN".

---

#### 9.4.2.18 Description of parameters 49

##### 49.4LIM - Response threshold of fault message

This parameter is used to set a value for the permissible size of the regulation deviation to trigger a fault message. The value is given in percent.

If the parameters "48.4TIM" and "49.4LIM" are set to "Auto", then the fault message is set if the slow motion zone is not reached within a certain period of time. The setting "Auto" is the factory setting. Within 5 to 95% of the actuator travel, this time is twice the initialization set time, and ten times the initialization set time outside of 10 to 90%.

---

##### Note

##### Activated tight closing function

If the tight closing function is activated, then for parameter "49.4LIM" the monitoring of regulation deviation is turned off in the appropriate overflow direction. Here, "YCDO: < 0 %" and "YCUP: > 100 %" apply. This functionality is especially advantageous for valves with soft seats. For a long-term monitoring of the end stop positions, we recommend activating the parameters "F.4ZERO" and "G.4OPEN".

---

### 9.4.2.19 Description of parameters 50

#### 50.PRST - Preset

These parameters are used to restore the factory settings and reset initialization. To do this, press the  button for at least 5 seconds.

In particular when the positioner was already used previously on a different actuator, you must always restore factory settings before a fresh initialization. Only in this way can you start from known starting conditions. The parameter "PRST" is available for this purpose.

It is recommended to restore factory settings when you have changed many parameters at once but cannot predict their effect, and there are then undesired reactions.

---

#### Note

If you have activated the "Preset" parameter value for the factory setting, then you must re-initialize the positioner. All previously configured maintenance parameters will be deleted.

---

### 9.4.2.20 Description of parameters 51

#### 51.XDIAG - Activation of extended diagnostics

This parameter is used to activate extended diagnostics. At the factory, extended diagnostics are deactivated. Parameter "51.XDIAG" is set to "OFF". To activate extended diagnostics, there are three modes available:

- On1: Extended diagnostics are activated. Threshold 3 error messages will be output over the fault message output.
- On2: Extended diagnostics are activated. Threshold 2 error messages will be activated using alarm output 2. Threshold 3 error messages will also be output over the fault message output.
- On3: Extended diagnostics are activated. Threshold 1 error messages will be activated using alarm output 1. Threshold 2 error messages will be activated using alarm output 2. Threshold 3 error messages will also be output over the fault message output.

---

#### Note

##### Activation of extended diagnostics

Please note that the parameters of extended diagnostics will only be shown in the display, from "A.4PST" to "P.4PAVG", following selection of one of the modes "On1" to "On3".

In the factory settings, parameters "A.4PST" to "P.4PST" are deactivated by default. Parameter "51.XDIAG" is set to "OFF". The corresponding parameters are only displayed after you activate the appropriate menu item with "On".

---

With extended diagnostics, the threshold of the error message is displayed using columns in addition to the error code. These columns are shown on the display as follows:



Figure 9-6 Display of a threshold 1 error message



Figure 9-7 Display of a threshold 2 error message



Figure 9-8 Display of a threshold 3 error message

The factory setting is "OFF".

### See also

Overview parameters A to P (Page 151)

### 9.4.3 Description of parameters A through P

#### 9.4.3.1 Description of parameter A

##### A.4PST - partial stroke test

Use this parameter to activate the partial stroke test for cyclic or manual testing of open/closed and control valves. Set the "On" parameter value to activate the test. Sub-parameters are displayed. If the sub-parameters are set to the desired parameter values, initiate the partial stroke test using:

- Buttons on the device
- A binary input
- Communication
- A cyclic test interval

Sub-parameters are described below.

The factory setting is "OFF".

##### A1.STPOS - starting position

Use this sub-parameter to define the starting position of the partial stroke test in percent. To this end, set the starting position within a range from "0.0" to "100.0".

The factory setting is "100.0".

##### A2.STTOL - starting tolerance

Use this sub-parameter to define the starting tolerance of the partial stroke test in percent. Set the starting tolerance relative to the starting position in a range from "0.1" to "10.0".

Example: You have set 50% as a starting position and 2% as a starting tolerance. In this case, a partial stroke test is initiated during operation only between a current position of 48 and 52%.

The factory setting is "2.0".

##### A3.STEP - stroke magnitude

Use this sub-parameter to define the stroke magnitude of the partial stroke test in percent. To this end, set the stroke magnitude within a range from "0.1" to "100.0".

The factory setting is "10.0".

#### **A4.STEPD - stroke direction**

Use this sub-parameter to set the stroke direction of the partial stroke test. The following parameter values are available:

- "uP" for up
- "do" for down
- "uP do" for up and down

If you select the "uP" parameter value, it leads to the following:

- The actuator moves from the starting position to the target position without control.
- After reaching the target position, the actuator moves back to the starting position in a controlled manner.

The target position is determined from the starting position **plus** the stroke magnitude.

The same procedure in the reverse order is applicable for the "do" parameter value.

If you select the "uP do" parameter value, it leads to the following:

- The actuator first moves from its starting position to the upper target position without control.
- Then, the actuator moves from the upper target position to the lower target position without control.
- After reaching the lower target position, the actuator moves back to the starting position in a controlled manner.

The upper target position is determined from the starting position **plus** the stroke magnitude. The lower target position is determined from the starting position **minus** the stroke magnitude.

The factory setting is "do".

#### **A5.INTRV - test interval**

Use this sub-parameter to enter the interval time for the cyclic partial stroke test in days. Set the test interval in a range from 1 to 365.

The factory setting is "OFF".

#### **A6.PSTIN - partial stroke test reference stroke time (PSTIN = partial stroke test initialization)**

Use this sub-parameter to measure the reference stroke time for the partial stroke test. The unit is seconds. The reference stroke time corresponds to the controlled movement from the starting position to the target position.

The positioner must be initialized in order to measure a reference stroke time. If the positioner is not yet initialized, the display shows "NOINI". If the positioner has already been initialized, the calculated average travel time of the control valve is displayed as a reference value.

Example: An average travel time of 1.2 seconds is shown in the display as "C 1.2", where "C" stands for "calculated". The average travel time can be used as a reference stroke time. However, it merely represents a rough default value.

Set the sub-parameters "A1" to "A5" as per your requirements. Then start measuring the reference stroke time by pressing the  $\triangle$  button for at least 5 seconds. The display shows "rEAL" during these 5 seconds.

The device then moves to the configured starting position automatically and executes the desired stroke. The current position in percent is continuously shown on the display. "inPST" for "initialize partial stroke test" appears in the lower line of the display. When the test is completed, the measured reference stroke time in seconds is shown. "Fdini" is displayed if the starting position cannot be approached or the stroke target cannot be achieved. "Fdini" stands for "failed PST initialization".

The factory setting is "NOINI".

### A7.FACT1 - factor 1

Use this sub-parameter to set the factor for the formation of limit threshold 1. Set the factor in a range from "0.1" to "100.0". The limit threshold is the product of the reference stroke time and "A7.FACT1". The process to determine the reference stroke time is described under "A6.PSTIN".

The threshold 1 error message is displayed when the limit threshold 1 is exceeded. The procedure to activate and display this error message is described in the "XDIAG" parameter.

The factory setting is "1.5".

### A8.FACT2 - factor 2

Use this sub-parameter to set the factor for the formation of limit threshold 2. Set the factor in a range from "0.1" to "100.0". The limit threshold is the product of the reference stroke time and "A8.FACT2". The process to determine the reference stroke time is described under "A6.PSTIN".

The threshold 2 error message is displayed when the limit threshold 2 is exceeded. The procedure to activate and display this error message is described in the "XDIAG" parameter.

The factory setting is "3.0".

### A9.FACT3 - factor 3

Use this sub-parameter to set the factor for the formation of limit threshold 3. Set the factor in a range from "0.1" to "100.0". The limit threshold is the product of the reference stroke time and "A9.FACT3". The process to determine the reference stroke time is described under "A6.PSTIN".

The threshold 3 error message is displayed when the limit threshold 3 is exceeded. The procedure to activate and display this error message is described in the "XDIAG" parameter.

If the time threshold is exceeded, the control signal of the actuator is simultaneously cancelled to prevent a sticky or rusty valve, if any, from breaking off and overshooting.

The partial stroke test is then interrupted temporarily, a threshold 3 error message is reported, and the actuator is moved back to its starting position.

The factory setting is "5.0".



### 9.4.3.2 Description of parameter b

#### **b.4.DEVI - general control valve fault**

Use this parameter to activate the general control valve fault test for dynamic monitoring of the control valve response. The actual position course is compared with the expected position course for this purpose. This comparison helps in drawing a conclusion about the correct operational response of the control valve. Set the "On" parameter value to activate the test. Sub-parameters are displayed. Sub-parameters are described below.

The current value is displayed in the "14 DEVI" diagnostics parameter. The positioner triggers a fault message if the current value exceeds one of the three configurable limit thresholds.

The factory setting is "OFF".

#### **b1.TIM - time constant of the low-pass filter**

Use this sub-parameter to define the attenuation effect of the low-pass filter. The unit is seconds. This sub-parameter is set to "Auto" if the device is initialized automatically. The "b1.TIM" time constant is determined from the initialization parameters such as "uP" and "doWn" actuating times.

If the time constant is not adequate, the setting of "b1.TIM" can be changed manually. Set the time constant in a range from "1" to "400". In this case:

- Setting "1" indicates too weak an attenuation.
- Setting "400" indicates too strong an attenuation.

The current value is displayed in the "14 DEVI" diagnostics parameter. The positioner triggers a fault message if the current value exceeds one of the three configurable limit thresholds.

The factory setting is "Auto".

#### **b2.LIMIT - limit of the general control valve fault**

Use this sub-parameter to set a base limit in percent. The base limit defines the magnitude of the permissible deviation from the expected position course. The limit serves as a reference variable for the fault message factors.

Set the base limit in a range from "0.1" to "100.0".

The factory setting is "1.0".

#### **b3.FACT1 - factor 1**

Use this sub-parameter to set the factor for the formation of limit threshold 1. Set the factor in a range from "0.1" to "100.0". The limit threshold is the product of "b2.LIMIT" and "b3.FACT1".

The threshold 1 fault message is displayed when the limit threshold 1 is exceeded. The process to activate and display this fault message is described in the "XDIAG" parameter.

The factory setting is "5.0".

**b4.FACT2 - factor 2**

Use this sub-parameter to set the factor for the formation of limit threshold 2. Set the factor in a range from "0.1" to "100.0". The limit threshold is the product of "b2.LIMIT" and "b4.FACT2".

The threshold 2 fault message is displayed when the limit threshold 2 is exceeded. The process to activate and display this fault message is described in the "XDIAG" parameter.

The factory setting is "10.0".

**b5.FACT3 - factor 3**

Use this sub-parameter to set the factor for the formation of limit threshold 3. Set the factor in a range from "0.1" to "100.0". The limit threshold is the product of "b2.LIMIT" and "b5.FACT3".

The threshold 3 fault message is displayed when the limit threshold 3 is exceeded. The process to activate and display this fault message is described in the "XDIAG" parameter.

The factory setting is "15.0".

**9.4.3.3 Description of parameter C**

**C.4LEAK - pneumatic leakage**

Use this parameter to activate the pneumatic leakage test. This test can be used to determine possible pneumatic leakages. Depending on the direction, changes in the position and the internal manipulated variable used for it are continuously recorded and filtered for this purpose. The filter result is used to form an indicator, which allows drawing a conclusion about a possible leakage.

---

**Note**

**Accuracy of results**

Note that this test delivers unambiguous results only in the case of single-acting, spring-loaded actuators.

---

Set the "On" parameter value to activate the test. Sub-parameters are displayed. Sub-parameters are described below.

The current value is displayed in the "15 ONLK" diagnostics parameter. The positioner triggers a fault message if the current value exceeds one of the three configurable limit thresholds.

The factory setting is "OFF".

### **C1.LIMIT - limit of the leakage indicator**

Use this sub-parameter to set the limit of the leakage indicator in percent. Set the limit in a range from "0.1" to "100.0". If no leakage exists, the leakage detection is automatically calibrated in such a way during the initialization (see chapter "Commissioning (Page 111)") that the leakage indicator remains below the value 30. If a value above 30 is displayed, this means that a leakage exists. "30.0" is therefore an advisable setting for the parameter. After a certain time this limit can be varied slightly depending on the application. To optimize the sensitivity of the leakage detection to your specific application, follow these steps:

1. After initializing the positioner automatically, use a calibration device to initiate a ramp movement.
2. Conditions for the ramp movement:
  - The ramp covers the normal operating range of the valve.
  - The steepness of the ramp matches the dynamic requirements of the corresponding application.
  - The characteristic of the ramp corresponds to the characteristic of the setpoint that actually occurs.
3. During the ramp movement, the "15 ONLK" diagnostics parameter provides information about the actual values. Define the limit of the leakage indicator accordingly.

The positioner triggers a fault message if the current value exceeds one of the three configurable limit thresholds. How to set the three limit thresholds is described below.

The factory setting is "30.0".

### **C2.FACT1 - factor 1**

Use this sub-parameter to set the factor for the formation of limit threshold 1. Set the factor in a range from "0.1" to "100.0". The limit threshold is the product of "C1.LIMIT" and "C2.FACT1".

The threshold 1 error message is displayed when the limit threshold 1 is exceeded. The procedure to activate and display this fault message is described in the "XDIAG" parameter.

The factory setting is "1.0".

### **C3.FACT2 - factor 2**

Use this sub-parameter to set the factor for the formation of limit threshold 2. Set the factor in a range from "0.1" to "100.0". The limit threshold is the product of "C1.LIMIT" and "C3.FACT2".

The threshold 2 error message is displayed when the limit threshold 2 is exceeded. The procedure to activate and display this fault message is described in the "XDIAG" parameter.

The factory setting is "1.5".

### **C4.FACT3 - factor 3**

Use this sub-parameter to set the factor for the formation of limit threshold 3. Set the factor in a range from "0.1" to "100.0". The limit threshold is the product of "C1.LIMIT" and "C4.FACT3".

The threshold 3 error message is displayed when the limit threshold 3 is exceeded. The procedure to activate and display this fault message is described in the "XDIAG" parameter.

The factory setting is "2.0".

#### 9.4.3.4 Description of parameter d

##### d.4STIC - static friction/slipstick effect

Use this parameter to continuously monitor the current static friction of the final controlling element (slipstick). If the parameter is activated, the positioner detects the slipstick effects that may occur. Sudden changes in the valve position, so-called slip jumps, indicate excessive friction. If slip jumps are detected, the filtered stroke magnitude is saved as a slipstick value. If slip jumps no longer exist, the slipstick value is reduced slowly.

Set the parameter value to "On" to activate the test. Sub-parameters are displayed. Sub-parameters are described below.

The current value is displayed in the "16 STIC" diagnostics parameter. The positioner triggers an error message if the current value exceeds a limit threshold.

---

##### Note

##### Incorrect interpretation in case of actuating times below one second

If the actuating times are less than one second, the positioner does not accurately differentiate between a normal movement of the actuator and a reverse change. Therefore, increase the actuating time if required.

---

The factory setting is "OFF".

##### d1.LIMIT - limit for slipstick detection

Use this sub-parameter to set the base limit for slipstick detection in percent. Set the base limit in a range from "0.1" to "100.0".

The factory setting is "1.0".

##### d2.FACT1 - factor 1

Use this sub-parameter to set the factor for the formation of limit threshold 1. Set the factor in a range from "0.1" to "100.0". The limit threshold is the product of "d1.LIMIT" and "d2.FACT1".

The threshold 1 error message is displayed when the limit threshold 1 is exceeded. The process to activate and display this error message is described in the "XDIAG" parameter.

The factory setting is "2.0".

##### d3.FACT2 - factor 2

Use this sub-parameter to set the factor for the formation of limit threshold 2. Set the factor in a range from "0.1" to "100.0". The limit threshold is the product of "d1.LIMIT" and "d3.FACT2".

The threshold 2 error message is displayed when the limit threshold 2 is exceeded. The process to activate and display this error message is described in the "XDIAG" parameter.

The factory setting is "5.0".

### d4.FACT3 - factor 3

Use this sub-parameter to set the factor for the formation of limit threshold 3. Set the factor in a range from "0.1" to "100.0". The limit threshold is the product of "d1.LIMIT" and "d4.FACT3".

The threshold 3 error message is displayed when the limit threshold 3 is exceeded. The process to activate and display this error message is described in the "XDIAG" parameter.

The factory setting is "10.0".

### 9.4.3.5 Description of parameter E

#### E.4DEBA - deadband monitoring

Use this parameter to activate the "deadband monitoring" test. This test can be used to monitor the automatic adjustment of deadbands continuously.

Configure the following settings to activate the test:

1. Ensure that the "31.DEBA" parameter is set to "Auto".
2. Set the "E.4DEBA" parameter to "On". The sub-menu to set the threshold value is displayed. The test is activated.
3. Change the parameter in the sub-menu if required. The setting option is described below.

The positioner triggers a fault message if the current deadband exceeds the configured limit threshold during the test.

The factory setting is "OFF".

#### E1.LEVL3 - threshold for monitoring the deadband adjustment

Use this sub-parameter to set the factor limit threshold to monitor the deadband adjustment. Set the threshold in a range from "0.1" to "10.0".

The threshold 3 fault message is displayed when the current deadband exceeds the threshold limit during the test. The procedure to activate and display this error message is described in the "XDIAG" parameter.

---

#### Note

##### Fault message display

A three-stage fault message display has not been implemented for deadband monitoring. The positioner triggers only threshold 3 fault messages depending on the setting.

---

The factory setting is "2.0".

### 9.4.3.6 Description of parameter F

#### F.4ZERO - zero point displacement

---

**Note****Fault detection**

The monitoring unit for the zero point displacement responds to the fault in the valve. If the limit thresholds of the zero point displacement are exceeded due to misalignment of the position feedback, the misalignment also triggers a diagnostics message.

---

Use this parameter to activate the test to monitor the zero point displacement. The test is executed whenever the valve is in the "down tight closing" position. The test checks whether the value of the lower end stop has changed with respect to its value at the time of initialization (zero point P0).

Configure the following settings to activate the test:

1. Ensure that the parameter "YCLS" manipulated variable tight closing parameter is set to values "do" or "uP do".
2. Set the "F.4ZERO" parameter to "On". Sub-parameters to set the test parameters are displayed. The test is activated.
3. Set the suitable parameter values in sub-parameters. The setting options available in sub-parameters are described below.

The current zero point displacement is displayed in the "17 ZERO" diagnostics parameter. The positioner triggers a fault message if the current value undershoots a threshold.

If the value undershoots a threshold, the fault message is saved in a power fail-safe manner until:

- No fault occurs during a repeat test.
- The device is re-initialized.
- The "F.4ZERO" parameter is deactivated.

The factory setting is "OFF".

#### F1.LEVL1 - threshold 1

Use this sub-parameter to set a threshold in percent. Use threshold 1 to monitor the lower hard end stop. Set the threshold in a range from "0.1" to "10.0".

The positioner triggers a fault message if the difference between the lower hard end stop and the initialization value undershoots threshold 1. The process to activate and display this fault message is described in the "XDIAG" parameter.

The factory setting is "1.0".

### F2.LEVL2 - threshold 2

Use this sub-parameter to set a threshold in percent. Use threshold 2 to monitor the lower hard end stop. Set the threshold in a range from "0.1" to "10.0".

The positioner triggers a fault message if the difference between the lower hard end stop and the initialization value undershoots threshold 2. The process to activate and display this fault message is described in the "XDIAG" parameter.

The factory setting is "2.0".

### F3.LEVL3 - threshold 3

Use this sub-parameter to set a threshold in percent. Use threshold 3 to monitor the lower hard end stop. Set the threshold in a range from "0.1" to "10.0".

The positioner triggers a fault message if the difference between the lower hard end stop and the initialization value undershoots threshold 3. The process to activate and display this fault message is described in the "XDIAG" parameter.

The factory setting is "4.0".

## 9.4.3.7 Description of parameter G

### G.4OPEN - displacement of upper end stop

---

#### Note

#### Fault detection

The monitoring unit for the displacement of the upper end stops does not only respond to the fault in the valve. If the limit thresholds of the displacement of the upper end stop are exceeded due to the misalignment of position feedback, the misalignment also triggers a diagnostics message.

---

Use this parameter to activate the test to monitor the displacement of the upper end stop. The test is executed whenever the valve is in the "up tight closing" position. The test checks whether the value of the upper hard end stop has changed with respect to its value at the time of initialization (end stop P100).

Configure the following settings to activate the test:

1. Ensure that the parameter "YCLS" manipulated variable tight closing parameter is set to values "uP" or "do uP".
2. Set the "G.4OPEN" parameter to "On". Sub-parameters to set the test parameters are displayed. The test is activated.
3. Set the suitable parameter values in sub-parameters. The setting options available in sub-parameters are described below.

The current displacement of the upper end stop is displayed in the "18 OPEN" diagnostics parameter. The positioner triggers a fault message if the current value exceeds a threshold.



If the value exceeds a threshold, the fault message is saved in a power fail-safe manner until:

- No fault occurs during a repeat test.
- The device is re-initialized.
- The "G.4OPEN" parameter is deactivated.

The factory setting is "OFF".

### **G1.LEVL1 - threshold 1**

Use this sub-parameter to set a threshold in percent. Use threshold 1 to monitor the upper hard end stop. Set the threshold in a range from "0.1" to "10.0".

The positioner triggers a fault message if the difference between the upper hard end stop and the initialization value exceeds threshold 1. The process to activate and display this fault message is described in the "XDIAG" parameter.

The factory setting is "1.0".

### **G2.LEVL2 - threshold 2**

Use this sub-parameter to set a threshold in percent. Use threshold 2 to monitor the upper hard end stop. Set the threshold in a range from "0.1" to "10.0".

The positioner triggers a fault message if the difference between the upper hard end stop and the initialization value exceeds threshold 2. The process to activate and display this fault message is described in the "XDIAG" parameter.

The factory setting is "2.0".

### **G3.LEVL3 - threshold 3**

Use this sub-parameter to set a threshold in percent. Use threshold 3 to monitor the upper hard end stop. Set the threshold in a range from "0.1" to "10.0".

The positioner triggers a fault message if the difference between the upper hard end stop and the initialization value exceeds threshold 3. The process to activate and display this fault message is described in the "XDIAG" parameter.

The factory setting is "4.0".

### 9.4.3.8 Description of parameter H

#### H.4TMIN - monitoring the lower limit temperature

Use this parameter to activate the test to continuously monitor the lower limit temperature inside the enclosure. The current temperature in the enclosure is recorded by a sensor on the electronic printed circuit board. The limit temperature is monitored in three stages.

Configure the following settings to activate the test:

1. Set the "H.4TMIN" parameter to "On". Sub-parameters to set the test parameters are displayed. The test is activated.
2. Set the suitable parameter values in sub-parameters. The setting options available in sub-parameters are described below.

The positioner triggers a fault message if the lower limit temperature undershoots a threshold during the test.

The factory setting is "OFF".

#### H1.TUNIT - temperature unit

Use this sub-parameter to set the temperature unit "°C" or "°F". The selected temperature unit is then also applicable for all other temperature-based parameters.

The factory setting is "°C".

#### H2.LEVL1 - threshold 1

Use this sub-parameter to set a threshold in "°C" or "°F". Use threshold 1 to monitor the lower limit temperature. Set the threshold in a range from "-40.0C" to "90.0C" or "-40.0F" to "194.0F".

The positioner triggers a fault message if the current temperature inside the enclosure undershoots threshold 1. The process to activate and display this fault message is described in the "XDIAG" parameter.

The factory setting is "-25.0C".

#### H3.LEVL2 - threshold 2

Use this sub-parameter to set a threshold in "°C" or "°F". Use threshold 2 to monitor the lower limit temperature. Set the threshold in a range from "-40.0C" to "90.0C" or "-40.0F" to "194.0F".

The positioner triggers a fault message if the current temperature inside the enclosure undershoots threshold 2. The process to activate and display this fault message is described in the "XDIAG" parameter.

The factory setting is "-30.0C".

### H4.LEVL3 - threshold 3

Use this sub-parameter to set a threshold in "°C" or "°F". Use threshold 3 to monitor the lower limit temperature. Set the threshold in a range from "-40.0C" to "90.0C" or "-40.0F" to "194.0F".

The positioner triggers a fault message if the current temperature inside the enclosure undershoots threshold 3. The process to activate and display this fault message is described in the "XDIAG" parameter.

The factory setting is "-40.0C".

### 9.4.3.9 Description of parameter J

#### J.4TMAX - monitoring the upper limit temperature

Use this parameter to activate the test to continuously monitor the upper limit temperature inside the enclosure. The current temperature in the enclosure is recorded by a sensor on the electronic printed circuit board. The limit temperature is monitored in three stages.

Configure the following settings to activate the test:

1. Set the "J.4TMAX" parameter to "On". Sub-parameters to set the test parameters are displayed. The test is activated.
2. Set the suitable parameter values in sub-parameters. The setting options available in sub-parameters are described below.

The positioner generates a fault message if the upper limit temperature exceeds a threshold during the test.

The factory setting is "OFF".

#### J1.TUNIT - temperature unit

Use this sub-parameter to set the temperature unit "°C" or "°F". The selected temperature unit is then also applicable for all other temperature-based parameters.

The factory setting is "°C".

#### J2.LEVL1 - threshold 1

Use this sub-parameter to set a threshold in "°C" or "°F". Use threshold 1 to monitor the upper limit temperature. Set the threshold in a range from "-40.0C" to "90.0C" or "-40.0F" to "194.0F".

The positioner triggers a fault message if the current temperature inside the enclosure exceeds threshold 1. The process to activate and display this fault message is described in the "XDIAG" parameter.

The factory setting is "75.0C".

### J3.LEVL2 - threshold 2

Use this sub-parameter to set a threshold in "°C" or "°F". Use threshold 2 to monitor the upper limit temperature. Set the threshold in a range from "-40.0C" to "90.0C" or "-40.0F" to "194.0F".

The positioner triggers a fault message if the current temperature inside the enclosure exceeds threshold 2. The process to activate and display this fault message is described in the "XDIAG" parameter.

The factory setting is "80.0C".

### J4.LEVL3 - threshold 3

Use this sub-parameter to set a threshold in "°C" or "°F". Use threshold 3 to monitor the upper limit temperature. Set the threshold in a range from "-40.0C" to "90.0C" or "-40.0F" to "194.0F".

The positioner triggers a fault message if the current temperature inside the enclosure exceeds threshold 3. The process to activate and display this fault message is described in the "XDIAG" parameter.

The factory setting is "90.0C".

## 9.4.3.10 Description of parameter L

### L.4STRK - monitoring the path integral

Use this parameter to monitor the entire path covered by the final controlling element continuously.

Configure the following settings to activate the test:

1. Set the "L.4STRK" parameter to "On". Sub-parameters to set the test parameters are displayed. The test is activated.
2. Set the suitable parameter values in sub-parameters. The setting options available in sub-parameters are described below.

The following is applicable for the version with PROFIBUS communication: This test determines the actuator movements in 100% strokes. In this case, a 100% stroke is equal to twice the complete path, e.g. from ON→OFF and OFF→ON.

The following is applicable for the standard version and the version with FOUNDATION fieldbus communication: This test determines the actuator movements in 100% strokes. In this case, a 100% stroke is equal to the complete path, e.g. from ON→OFF or OFF→ON.

The current value is displayed in the "1 STRKS" diagnostics parameter. The positioner triggers a fault message if the current value exceeds a limit threshold.

The factory setting is "OFF".

### **L1.LIMIT - limit for the number of strokes**

Use this sub-parameter to set the base limit for the number of strokes. Set the base limit in a range from "1" to "1.00E8".

The factory setting is "1.00E6".

### **L2.FACT1 - factor 1**

Use this sub-parameter to set the factor for the formation of limit threshold 1. Set the factor in a range from "0.1" to "40.0". The limit threshold is the product of "L1.LIMIT" and "L2.FACT1".

The threshold 1 fault message is displayed when the limit threshold 1 exceeds. The process to activate and display this fault message is described in the "XDIAG" parameter.

The factory setting is "1.0".

### **L3.FACT2 - factor 2**

Use this sub-parameter to set the factor for the formation of limit threshold 2. Set the factor in a range from "0.1" to "40.0". The limit threshold is the product of "L1.LIMIT" and "L3.FACT2".

The threshold 2 fault message is displayed when the limit threshold 2 exceeds. The process to activate and display this fault message is described in the "XDIAG" parameter.

The factory setting is "2.0".

### **L4.FACT3 - factor 3**

Use this sub-parameter to set the factor for the formation of limit threshold 3. Set the factor in a range from "0.1" to "40.0". The limit threshold is the product of "L1.LIMIT" and "L4.FACT3".

The threshold 3 fault message is displayed when the limit threshold 3 exceeds. The process to activate and display this fault message is described in the "XDIAG" parameter.

The factory setting is "5.0".

### **See also**

Display of diagnostics values (Page 197)

## **9.4.3.11 Description of parameter O**

### **O.DCHG - monitoring the change of direction**

Use this parameter to continuously monitor the number of changes of direction of the actuator caused in the deadband.

Configure the following settings to activate the test:

1. Set the "O.DCHG" parameter to "On". Sub-parameters to set the test parameters are displayed. The test is activated.
2. Set the suitable parameter values in sub-parameters. The setting options available in sub-parameters are described below.

The current value is displayed in the "2 CHDIR" diagnostics parameter. The positioner triggers a fault message if the current value exceeds a limit threshold.

The factory setting is "OFF".

### **O1.LIMIT - limit for the change of direction**

Use this sub-parameter to set the base limit for the number of changes of direction of the actuator. Set the base limit in a range from "1" to "1.00E8".

The factory setting is "1.00E6".

### **O2.FACT1 - factor 1**

Use this sub-parameter to set the factor for the formation of limit threshold 1. Set the factor in a range from "0.1" to "40.0". The limit threshold is the product of "O1.LIMIT" and "O2.FACT1".

The threshold 1 error message is displayed when the limit threshold 1 is exceeded. The procedure to activate and display this error message is described in the "XDIAG" parameter.

The factory setting is "1.0".

### **O3.FACT2 - factor 2**

Use this sub-parameter to set the factor for the formation of limit threshold 2. Set the factor in a range from "0.1" to "40.0". The limit threshold is the product of "O1.LIMIT" and "O3.FACT2".

The threshold 2 error message is displayed when the limit threshold 2 is exceeded. The procedure to activate and display this error message is described in the "XDIAG" parameter.

The factory setting is "2.0".

### **O4.FACT3 - factor 3**

Use this sub-parameter to set the factor for the formation of limit threshold 3. Set the factor in a range from "0.1" to "40.0". The limit threshold is the product of "O1.LIMIT" and "O4.FACT3".

The threshold 3 error message is displayed when the limit threshold 3 is exceeded. The procedure to activate and display this error message is described in the "XDIAG" parameter.

The factory setting is "5.0".

### **See also**

Display of diagnostics values (Page 197)

### 9.4.3.12 Description of parameter P

#### P.4PAVG - calculation of position average

Use this parameter to activate the test to calculate and monitor the position average.

Configure the following settings to activate the test:

1. Set the "P.4PAVG" parameter to "On". Sub-parameters to set the test parameters are displayed. The test is activated.
2. Set the suitable parameter values in sub-parameters. The setting options available in sub-parameters are described below.

During the test, the position and reference average values are always compared at the end of a time interval. The positioner triggers an error message if the current position average exceeds a threshold.

The factory setting is "OFF".

#### P1.TBASE - time base for averaging

Use this sub-parameter to set the time interval to calculate the position average.

The following values are available to define the time intervals:

- 30 minutes
- 8 hours
- 5 days
- 60 days
- 2.5 years

After starting the reference average calculation and the expiry of the time interval, a position average over the interval period is determined and compared with the reference average. The test is then restarted.

The factory setting is "0.5 h".

#### P2.STATE - status of the position average calculation

Use this sub-parameter to start the calculation of the position average. If a reference average has never been determined, the parameter value is "IdLE".

Then start the calculation by pressing the  button for 5 seconds. The value in the display changes from "IdLE" to "rEF". The reference average is calculated.

When the time interval expires, the calculated reference average is shown on the display.

---

**Note**

**Current position average**

The respective current position average is displayed in the "19.PAVG" diagnostics parameter. If no position average has been calculated, "COMP" is displayed in the "19.PAVG" diagnostics parameter.

---

The factory setting is "IdLE".

**P3.LEVL1 - threshold 1**

Use this sub-parameter to set threshold 1 for the maximum deviation of the current position average from the reference average. Set the threshold in a range from "0.1" to "100.0".

The positioner triggers an error message if the difference between the position average and the reference average exceeds threshold 1. The procedure to activate and display this error message is described in the "XDIAG" parameter.

The factory setting is "2.0".

**P4.LEVL2 - threshold 2**

Use this sub-parameter to set threshold 2 for the maximum deviation of the current position average from the reference average. Set the threshold in a range from "0.1" to "100.0".

The positioner triggers an error message if the difference between the position average and the reference average exceeds threshold 2. The procedure to activate and display this error message is described in the "XDIAG" parameter.

The factory setting is "5.0".

**P5.LEVL3 - threshold 3**

Use this sub-parameter to set threshold 3 for the maximum deviation of the current position average from the reference average. Set the threshold in a range from "0.1" to "100.0".

The positioner triggers an error message if the difference between the position average and the reference average exceeds threshold 3. The procedure to activate and display this error message is described in the "XDIAG" parameter.

The factory setting is "10.0".



## Alarm, error, and system messages

### 10.1 Output of system messages in the display

#### 10.1.1 System messages before initialization

Remarks about the tables:

- nn stands for variable numeric values
- ↳ Error symbol
- / (slash): the texts on the left and right of the slash flash alternately

#### Messages before initialization (first commissioning)

Message	Line		Meaning / cause	Remedy
	Up	Down		
CPUStart	X	X	Message after application of electrical auxiliary power	<ul style="list-style-type: none"> <li>• Maintenance</li> </ul>
Pnnn.n	X		Potentiometer voltage of a non-initialized positioner (P-manual mode) (actual position value in % of the measuring range)	<ul style="list-style-type: none"> <li>• Check whether the entire actuator travel can be covered using the "+" and "-" buttons and "P---" is never displayed</li> <li>• Execute the initialization process</li> </ul>
P---	X		Measuring range was exceeded, the potentiometer is in the inactive zone, the transmission ratio selectors or the effective lever arm are not adjusted as per the actuator travel	<ul style="list-style-type: none"> <li>• Switch the transmission ratio selector to 90° especially in case of part-turn actuators</li> <li>• Adjust the effective lever length of linear actuators as per the measuring range</li> </ul>
NOINI		X	Positioner is not initialized	<ul style="list-style-type: none"> <li>• Start initialization</li> </ul>

#### See also

Display (Page 101)

### 10.1.2 System messages during initialization

Remarks about the tables:

- nn stands for variable numeric values
- ↳ Error symbol
- / (slash): the texts on the left and right of the slash flash alternately

#### Messages during initialization

Message	Line		Meaning / cause	Remedy
	Up	Down		
P--	X		Measuring range was exceeded, the potentiometer is in the inactive zone, the transmission ratio selectors or the effective lever arm are not adjusted as per the actuator travel	<ul style="list-style-type: none"> <li>• Switch the transmission ratio selector to 90° especially in case of part-turn actuators</li> <li>• Adjust the effective lever length of linear actuators as per the measuring range</li> </ul>
RUN1		X	Initialization was started, part 1 is active (the direction of action is determined)	<ul style="list-style-type: none"> <li>• Maintenance</li> </ul>
RUN2		X	Initialization part 2 is active (actuator travel check and determination of end stops)	<ul style="list-style-type: none"> <li>• Maintenance</li> </ul>
RUN3		X	Initialization part 3 is active (determination and display of travel times)	<ul style="list-style-type: none"> <li>• Maintenance</li> </ul>
RUN4		X	Initialization part 4 is active (determination of the minimum controller increment length)	<ul style="list-style-type: none"> <li>• Maintenance</li> </ul>
RUN5		X	Initialization part 5 is active (optimization of the transient response)	<ul style="list-style-type: none"> <li>• Wait until "FINSH" is displayed (initialization completed successfully)</li> <li>• Acknowledge by pressing the operating mode button briefly and exit the configuration level by pressing it longer</li> </ul>
YEND1		X	The first end position can be approached only in case of a manual initialization	<ul style="list-style-type: none"> <li>• Approach the first end position using the "+" or "-" button</li> <li>• Acknowledge using the operating mode button</li> </ul>
YEND2		X	The second end position can be approached only in case of a manual initialization	<ul style="list-style-type: none"> <li>• Approach the second end position using the "+" or "-" button</li> <li>• Acknowledge using the operating mode button</li> </ul>

## 10.1 Output of system messages in the display

Message	Line		Meaning / cause	Remedy
	Up	Down		
RANGE		X	The end position or the measuring span is beyond the permissible measuring range only in case of a manual initialization	<ul style="list-style-type: none"> <li>Approach another end position using the "+" and "-" buttons and acknowledge with the operating mode button, or</li> <li>Move the friction clutch until "ok" is displayed, and then acknowledge with the operating mode button, or</li> <li>Terminate the initialization process by pressing the operating mode button, switch to the P-manual mode and correct the actuator travel and the position displacement sensor</li> </ul>
ok		x	The permissible measuring range of end positions is achieved only in case of a manual initialization	<ul style="list-style-type: none"> <li>Acknowledge with the operating mode button; the remaining steps ("RUN1" to "FINSH") execute automatically</li> </ul>
RUN1 / ERROR		X	Error in "RUN1", no movement e.g. due to the lack of compressed air	<ul style="list-style-type: none"> <li>Provide adequate compressed air</li> <li>Open the restrictor(s)</li> <li>Restart the initialization process</li> </ul>
↳d__U		X	Bar graph display of the zero point; zero point is beyond the tolerance range	<ul style="list-style-type: none"> <li>Set between "P 4.0" and "P .9" ( &gt;0&lt; ) using a friction clutch</li> <li>Continue with the "+" or "-" button</li> </ul>
SEt	X		Friction clutch was moved; "P 50.0" not displayed when the lever is horizontal	<ul style="list-style-type: none"> <li>In case of linear actuators, use the "+" and "-" buttons to bring the lever perpendicular to the spindle</li> <li>Press the operating mode button slightly to acknowledge (the initialization process is continued)</li> </ul>
MIDDL		X		
↳UP >		X	"UP" tolerance range was exceeded or the inactive zone of the potentiometer was covered	<ul style="list-style-type: none"> <li>Increase the effective lever length of the linear actuators or switch the transmission ratio selector to 90°</li> <li>Press the operating mode button slightly to acknowledge</li> <li>Restart the initialization process</li> </ul>
↳90_95		X	Possible only in case of part-turn actuators: actuator travel is not in the range between 90 and 95%	<ul style="list-style-type: none"> <li>Use the "+" and "-" buttons to move it in the range between 90 and 95%</li> <li>Press the operating mode button slightly to acknowledge</li> </ul>
↳U-d>		X	"Up-Down" measuring span was undershot	<ul style="list-style-type: none"> <li>Decrease the effective lever length of the linear actuators or switch the transmission ratio selector to 33°</li> <li>Press the operating mode button slightly to acknowledge</li> <li>Restart the initialization process</li> </ul>

10.1 Output of system messages in the display

Message	Line		Meaning / cause	Remedy
	Up	Down		
U nn.n	X		Display of the "Up" travel time	<ul style="list-style-type: none"> <li>• Wait, or</li> <li>• To change the travel time, interrupt the initialization process with the "-" button, or</li> <li>• Activate the leakage test with the "+" button</li> </ul>
D->U		X		
D nn.n	X		Display of the "Down" travel time	<ul style="list-style-type: none"> <li>• Wait, or</li> <li>• To change the travel time, interrupt the initialization process with the "-" button, or</li> <li>• Activate the leakage test with the "+" button</li> </ul>
U->d		X		
NOZZL		X	Actuator stops (the initialization process was interrupted using the "-" button when the actuation speed display was active)	<ul style="list-style-type: none"> <li>• The travel time can be changed by adjusting the restrictor(s)</li> <li>• Redetermine the speed of shifting using the "-" button</li> <li>• Continue with the "+" button</li> </ul>
TES <sub>t</sub>	X		Leakage test active (the "+" button was pressed when the actuation speed display was active)	<ul style="list-style-type: none"> <li>• Wait for 1 minute</li> <li>• Continue with the "+" button</li> </ul>
LEAKG		X		
nn.n	X		Value and unit of the result after the leakage test	<ul style="list-style-type: none"> <li>• Rectify the leakage if the value is too large</li> <li>• Continue with the "+" button</li> </ul>
%/MIN		X		
nn.n	X		Initialization completed successfully with the display of actuator travel or the actuator angle	<ul style="list-style-type: none"> <li>• Acknowledge by pressing the operating mode button briefly and exit the configuration level by pressing it longer</li> </ul>
FINISH		X		

See also

System messages before initialization (Page 191)

### 10.1.3 System messages when exiting the Configuration mode

Remarks about the tables:

- nn stands for variable numeric values
- ↳ Error symbol
- / (slash): the text to the left and right of the slash blink interchangeably.

Messages when exiting the configuration mode:

Message	Goals		Operating mode			Meaning / Cause	Measure
	Up	Down	Automatic	Manual mode	P Manual mode		
n.nn.nnV ER	X					Software version	<ul style="list-style-type: none"> <li>• Wait</li> </ul>
ErrorSLn n	X					Monotony interruption of the free characteristic on the setpoint turning point n	<ul style="list-style-type: none"> <li>• Correct value</li> </ul>

### 10.1.4 System messages during operation

Remarks on the tables:

- nn stands for changeable numeric values
- ↳ Error symbol
- / (slash): the texts on the left and right of the slash flash alternately

Messages during operation:

Message	Line		Mode			Meaning / cause	Measure
	Above	Below	Automatic	Manual	P-manual		
CPUSTART	X					Message after application of electrical auxiliary power	<ul style="list-style-type: none"> <li>• Maintenance</li> </ul>
HW / ERROR		X				Fault in the hardware	<ul style="list-style-type: none"> <li>• Replace electronics</li> </ul>
NOINI		X			X	Positioner is not initialized	<ul style="list-style-type: none"> <li>• Start initialization</li> </ul>

10.1 Output of system messages in the display

Message	Line		Mode			Meaning / cause	Measure
	Above	Below	Automatic	Manual	P-manual		
nnn.n	X		X	X		Actual position [in %] for initialized positioner. Flashing decimal point shows communication with a class-2 master	
AUTnn		X	X			Automatic mode (nn = setpoint)	
MANnn				X		Manual mode (nn = setpoint)	<ul style="list-style-type: none"> <li>Switch to automatic mode with mode button</li> </ul>
oFL / 127.9	X		X	X		Display range exceeded. Possible causes: <ul style="list-style-type: none"> <li>Friction clutch or</li> <li>transmission ratio selector was disturbed or</li> <li>Positioner was installed on a different actuator without being reinitialized</li> </ul>	<ul style="list-style-type: none"> <li>Offset friction clutch so that when the actuator moves the actual value display stays between 0.0 and 100.0, or</li> <li>transmission ratio selector, or</li> <li>perform factory settings (Preset) and initialization</li> </ul>
EXSTP		X	X			Actuator was stopped with the binary input	
EX UP		X	X			Actuator is moved to the upper stop with binary input	
EXDWN		X	X			Actuator is moved to the lower stop with binary input	
EXTPSt						Partial-Stroke-Test was activated, e.g. through binary input	
InPSt						Cyclic Partial-Stroke-Test	
HTCNF		X	X	X	X	HART configuration running	

## 10.2 Diagnosis

### 10.2.1 Display of diagnostics values



#### Structure of the diagnostics display

The diagnostics display has similar structure to that of the "Configuration" mode:



- The upper line shows the value of the diagnostics variable.
- The lower line shows the number and the abbreviation of the displayed variable.

Some diagnostics value can be greater than 99999. In such a case, the display switches over to the exponential view. Example: The value "1234567" is shown as "1.23E6".

#### General procedure

1. Press all three buttons at the same time for at least 2 seconds. You are now in the diagnostics display.
2. Use the  button to select the next diagnostics value.
3. Press the  button for at least 2 seconds in order to exit the diagnostics display.

#### How to show the diagnostics values in reverse order

Press the  and  buttons simultaneously.

#### How to set values to zero

Specific values can be set to zero by pressing the  button for at least 5 seconds.

#### See also

Description of parameter L (Page 186)

Description of parameter O (Page 187)

### 10.2.2 Overview of diagnostics values

#### Explanation about the table

The following table provides an overview of values that can be displayed. The third column contains the German meaning and the corresponding English term used to derive the abbreviation if it is not self-explanatory. The last column contains "X" if the value can be set to zero.

## Overview of diagnostics values

No.	Abbreviation	Meaning	Values that can be displayed	Unit	Reset possible
1	STRKS	Stroke number	0 ... 4.29E9	-	X
2	CHDIR		0 ... 4.29E9	-	X
3	LCNT	Number of fault messages	0 ... 4.29E9	-	X
4	A1CNT	Number of alarms 1	0 ... 4.29E9	-	X
5	A2CNT	Number of alarms 2	0 ... 4.29E9	-	X
6	HOURS	Operating hours	0 ... 4.29E9	Hours	-
7	WAY	Determined actuator travel	0 ... 130	mm or °	-
8	TUP	Travel time up	0 ... 1000	s	-
9	TDOWN	Travel time down	0 ... 1000	s	-
10	LEAK	Leakage	P 0.0 ... 100.0	%	-
11	PST	Monitoring of the partial stroke test	OFF / ###.#, fdini, notSt, SdtSt, fdtSt, notd, Strt	s for ###.#	-
12	PRPST	time since the last partial stroke test	###, notSt, Sdtst, fdtSt	Days	-
13	NXPST	time until the next partial stroke test	###, notSt, SdtSt, fdtSt	Days	-
14	DEVI	General control valve fault	OFF, 0.0 ... 100.0	%	-
15	ONLK	Pneumatic leakage	OFF, 0.0 ... 100.0	-	-
16	STIC	Stiction	OFF, 0.0 ... 100.0	%	-
17	ZERO	Zero point displacement	OFF, 0.0 .. 100.0	%	-
18	OPEN	Displacement of upper end stop	OFF, 0.0 ... 100.0	%	-
19	PAVG	Position average	0.0 ... 100.0	%	-
20	P0	Potentiometer value of lower end stop (0%)	0.0 ... 100.0	%	-
21	P100	Potentiometer value of upper end stop (100%)	0.0 ... 100.0	%	-
22	IMPUP	impulse length up	6 ... 160	ms	-
23	IMPDN	impulse length down	6 ... 160	ms	-
24	DBUP	deadband up	0.1 ... 10.0	%	-
25	DBDN	deadband down	0.1 ... 10.0	%	-
26	SSUP	slow step zone up	0.1 ... 100.0	%	-
27	SSDN	slow step zone down	0.1 ... 100.0	%	-
28	TEMP	Current temperature	-40 ... 85	°C	-
29	TMIN	Minimum temperature ("min/max pointer")	-40 ... 85	°C	-
30	TMAX	Maximum temperature ("min/max pointer")	-40 ... 85	°C	-
31	T1	Number of operating hours in temperature range 1	0 ... 4.29E9	Hours	-
32	T2	Number of operating hours in temperature range 2	0 ... 4.29E9	Hours	-
33	T3	Number of operating hours in temperature range 3	0 ... 4.29E9	Hours	-
34	T4	Number of operating hours in temperature range 4	0 ... 4.29E9	Hours	-



No.	Abbreviation	Meaning	Values that can be displayed	Unit	Reset possible
35	T5	Number of operating hours in temperature range 5	0 ... 4.29E9	Hours	-
36	T6	Number of operating hours in temperature range 6	0 ... 4.29E9	Hours	-
37	T7	Number of operating hours in temperature range 7	0 ... 4.29E9	Hours	-
38	T8	Number of operating hours in temperature range 8	0 ... 4.29E9	Hours	-
39	T9	Number of operating hours in temperature range 9	0 ... 4.29E9	Hours	-
40	VENT1	Number of switching cycles of pilot valve 1	0 ... 4.29E9	-	-
41	VENT2	Number of switching cycles of pilot valve 2	0 ... 4.29E9	-	-
42	STORE	Save the current values as "last maintenance" (press the increment button for 5 s)	-	-	-
43	PRUP	Prediction up	1 ... 40	-	-
44	PRDN	Prediction down	1 ... 40	-	-
45	WT00	Number of operating hours in the actuating range WT00	0 ... 4.29E9	Hours	X
46	WT05	Number of operating hours in the actuating range WT05	0 ... 4.29E9	Hours	X
47	WT10	Number of operating hours in the actuating range WT10	0 ... 4.29E9	Hours	X
48	WT30	Number of operating hours in the actuating range WT30	0 ... 4.29E9	Hours	X
49	WT50	Number of operating hours in the actuating range WT50	0 ... 4.29E9	Hours	X
50	WT70	Number of operating hours in the actuating range WT70	0 ... 4.29E9	Hours	X
51	WT90	Number of operating hours in the actuating range WT90	0 ... 4.29E9	Hours	X
52	WT95	Number of operating hours in the actuating range WT95	0 ... 4.29E9	Hours	X

### Diagnostic value 53

No.	Abbreviation	Meaning	Values that can be displayed	Unit	Reset possible
53	mA	Setpoint current	0.0 to 20.0	mA	--

### 10.2.3 Meaning of the diagnostics values

#### 1 STRKS - stroke number

In operation, the movements of the actuator are summed up and displayed in this diagnostics value as the stroke number. Unit: 100% strokes, i.e. the path between 0 and 100% and back. The value is written in a non-volatile memory every 15 minutes. The non-volatile memory can be set to zero using the  button.

#### 2 CHDIR - number of changes of direction

Every change of direction of the actuator caused in the deadband is noted in the closed-loop controller and added to the number of changes of direction.

The value is written in a non-volatile memory every 15 minutes. The non-volatile memory can be set to zero using the  button.

#### 3 CNT - number of fault messages

Every fault is noted in the closed-loop controller and added to the number of fault messages. The counter can be set to zero using the  button.

#### 4 A1CNT - number of alarms 1

and

#### 5 A2CNT - number of alarms 2

These two counters indicate how often alarms 1 and 2 have been triggered. Activation of alarms using the "AFCT" parameter is a requirement for this. The counters can be set to zero using the  button.

#### 6 HOURS - operating hours

The runtime meter is incremented every hour as soon as electric auxiliary power is supplied to the positioner.

#### 7 WAY - determined actuator travel

This value indicates the actuator travel determined during the initialization process as per the display at the end of an initialization process. Requirement for linear actuators: Specification of the lever arm using the "YWAY" parameter.

## 8 TUP - actuating time up

## 9 TDOWN - actuating time down

These values indicate the actuating times determined during the initialization process. The unit is seconds.

## 10 LEAK - leakage

If a leakage measurement was initiated during the initialization process, the leakage value in %/min can be read in this parameter.

## 11 PST - monitoring of the Partial-Stroke test

This parameter indicates the stroke time measured during the last partial stroke test. A partial stroke test can be initiated manually or a current partial stroke test can be interrupted by pressing the  button.

The following states are output in the display:

- OFF  
The partial stroke test function is deactivated in the configuration menu.
- FdIni - Failed PST Initialization  
The reference stroke time measurement of the partial stroke test has failed.
- notSt - No Test  
A manual partial stroke test has not yet been executed.
- ###.# (measured stroke time in seconds)  
The last partial stroke test was successfully executed.
- SdtSt - Stopped Test  
The last partial stroke test was interrupted.
- FdtSt - Failed Test  
The last partial stroke test has failed.

The following status messages appear when you press the  button:

- notoL - No Tolerance  
The control valve is beyond the tolerance range to start the partial stroke test. A manual partial stroke test is not started.
- Strt - Start  
A manual partial stroke test is started five seconds after pressing the button.
- StoP - Stop  
The current partial stroke test is interrupted.

### 12 PRPST - time since the last partial stroke test

This parameter shows the elapsed time in days since the last partial stroke test. In addition, the following status messages can be displayed:

- notSt - No Test  
A manual partial stroke test has not yet been executed.
- SdtSt - Stopped Test  
The last Partial-Stroke-Test was interrupted.
- FdtSt - Failed Test  
The last partial stroke test has failed.

### 13 NXPST - time until the next partial stroke test

This parameter shows the time in days until the next partial stroke test. The conditions are that the partial stroke test is activated in the configuration menu and a test interval is set. If one of the above-mentioned conditions is not met, "OFF" is shown on the display.

### 14 DEVI - general control valve fault

This value provides information about the present dynamically determined deviation from the model response. If the underlying function is deactivated in the configuration menu, "OFF" is displayed.

### 15 ONLK - pneumatic leakage

This parameter shows the current leakage indicator. If the leakage detection is deactivated in the configuration menu, "OFF" is displayed.

### 16 STIC - static friction/slipstick effect

This parameter shows the filtered value of the stroke magnitude in percent resulting from the static friction. If the function is deactivated in the configuration menu, "OFF" is displayed.

### 17 ZERO - zero point displacement

Display of the current displacement of the lower hard end stop with respect to its initialization value. The activation of the "down tight closing function" is a condition to determine this. Activate using the "YCLS" parameter in the configuration menu. If the underlying function is deactivated in the configuration menu, "OFF" is displayed.

### 18 OPEN - displacement of upper end stop

Display of the current displacement of the upper hard end stop with respect to its initialization value. The activation of the "up tight closing function" is a condition to determine this. Activate using the "YCLS" parameter in the configuration menu. If the underlying function is deactivated in the configuration menu, "OFF" is displayed.

## 19 PAVG - position average

This value shows the last calculated comparison average. The following status messages are also available:

- OFF  
The underlying function is deactivated in the configuration menu.
- IdLE (inactive)  
The function has not been started yet.
- rEF (the reference average is calculated)  
The function was started, and the reference interval is in progress at the moment.
- COMP (the comparison average is calculated)  
The function was started, and the comparison interval is in progress at the moment.

## 20 P0 - potentiometer value of the lower end stop

## 21 P100 - potentiometer value of the upper end stop

Both these values indicate the measured values of the position displacement sensor (potentiometer) on the lower or upper hard end stop, as they were determined during automatic initialization. The values of manually approached end positions are applicable for manual initialization.

## 22 IMPUP - impulse length up

This parameter can be set for special applications.

## 23 IMPDN - impulse length down

The smallest impulse lengths that can be used to move the actuator are determined during the initialization process. They are separately determined for the "Up" and "Down" directions and displayed here.

This parameter can be set for special applications.

## 24 DBUP - deadband up

## 25 DBDN - deadband down

This parameter shows the deadbands of the controller in the "Open" and "Closed" directions. The values correspond either to the manually configured value of the "DEBA" parameter or to the value automatically adapted by the device if DEBA" was set to "Auto".

## 26 SSUP - slow step zone up

This parameter can be set for special applications.

**27 SSDN - slow step zone down**

The slow step zone is the zone of the closed-loop controller in which control signals are issued in a pulsed manner. The impulse length is thus proportional to the control deviation. If the control deviation is beyond the slow step zone, the valves are controlled using permanent contact.

This parameter can be set for special applications.

**28 TEMP - current temperature**

Current temperature in the positioner enclosure. The sensor is provided on the electronic printed circuit board.

In order to switch over the temperature display between °C and °F, press the ▽ button.

**29 TMIN - minimum temperature ("min/max pointer")**

**30 TMAX - maximum temperature ("min/max pointer")**

The minimum and maximum temperatures inside the enclosure are continuously determined and saved using a min/max pointer. They can be reset only in the factory.

**31 T1 ... 39 T9 - number of operating hours in temperature ranges T1 to T9**

Statistics about the duration of operation in different temperature ranges is maintained in the device. An average of the measured temperature is taken every hour and the counter assigned to the corresponding temperature range is incremented. This helps in drawing conclusions about the past operating conditions of the device and the entire control valve.

The temperature ranges are classified as follows:

	T1	T2	T3	T4	T5	T6	T7	T8	T9
Temperature range [°C]	-	≥ -30	≥ -15	≥ 0	≥ 15	≥ 30	≥ 45	≥ 60	≥ 75
	≥ -30	< -15	< 0	< 15	< 30	< 45	< 60	< 75	-

Operating hours in temperature ranges T1 to T2

**40 VENT1 - number of switching cycles of pilot valve 1**

**41 VENT2 - number of switching cycles of pilot valve 2**

Both these counters sum up the control processes of pilot valves and are used to assess the switching frequency.

**42 STORE - save maintenance data**

Press the  button for at least 5 seconds in order to exit the save function. The diagnostics data 7 to 10 and 20 to 27 is saved in the non-volatile memory as "data of last maintenance". This diagnostics data contains selected values whose changes can give information about mechanical wear and tear of the valve.

This function is normally operated through the PDM, menu command "Device-> Save maintenance info". The data of the last maintenance data can be compared with the current data using the PDM.

**43 PRUP - prediction up**

and

**44 PRDN - prediction down**

See also Optimizing the controller data (Page 109)

**45 WT00 bis 52 WT95 - number of operating hours in the actuating ranges WT00 to WT95**



When the positioner is in the automatic mode, statistics regarding the duration for which a valve or a flap operated in a particular section of the actuating range are continuously maintained. The entire actuating range is divided into 8 sections from 0 to 100 %. The positioner records the current position continuously and increments the runtime meter assigned to the corresponding actuating range every hour. This helps in drawing conclusions about the past operating conditions and especially in assessing the control properties of the control loop and the entire control valve.

The actuating range is divided as follows:

Actuating range	WT00	WT05	WT10	WT30	WT50	WT70	WT90	WT95
Actuating range section [%]	-	≥ 5	≥ 10	≥ 30	≥ 50	≥ 70	≥ 90	≥ 95
	< 5	< 10	< 30	< 50	< 70	< 90	< 95	-

Division of actuating range

You can simultaneously set the eight operating hours counters to zero. To do this, press the  button for at least 5 seconds.

**TIP:** Since the actuating ranges are provided at the end of the diagnostics menu, press the  decrement button several times along with the  button. This will help you in accessing the diagnostics numbers faster.

**Note****Updating of the diagnostics values**

All diagnostics values are updated in the non-volatile memory every 15 minutes so that, in case of a power failure, only the values of the previous 15 minutes may be lost.

**See also**

Description of parameters 13 through 33 (Page 161)



## 10.2.4 Meaning of diagnostic value 53

### 53 mA - setpoint current

Here, you can display the current setpoint in mA.

---

#### Note

All diagnostic value are updated every 15 minutes to a non-volatile memory, so that in case of a power failure only the values from the last quarter hour will be lost.

---

## 10.3 Online diagnostics

### 10.3.1 Overview of online diagnostics

Online diagnostics means diagnostics during ongoing operation. During operation of the positioner, a few important values and parameters are continually monitored. In configuration mode, you can configure that monitoring so that the fault message output will be activated if, for instance, a limit is exceeded.

Information about what events can activate the fault message output can be found in the table in section "Overview of error codes (Page 208)".

This section contains particular information about the following situations:

- Possible causes of the fault message.
- Events which activate the fault message output or alarm outputs.
- Settings of parameters needed for event monitoring.
- Cancelling a fault message

When the fault message output is triggered in automatic or manual mode, the display shows which fault triggered the message. The two digits on the lower left show the corresponding error code. If multiple triggers occur at the same time, they are displayed one after the other cyclically. The device status, including all fault messages, can be called up using command "#48" over HART.

#### See also

Description of parameters 51 (Page 170)

Description of parameters A through P (Page 172)

## 10.3.2 Overview of error codes

## Overview of error codes that activate the fault message output

Error code	Three-stage	Event	Parameter setting	Error message disappears when	Possible causes
h1	No	Remaining control deviation	Always active	... the control deviation disappears again.	Compressed air failure, actuator fault, valve fault (e.g. blockade).
h2	No	Device not in the automatic mode	** .hFCT <sup>1)</sup> =h <sub>1</sub> nA or = h <sub>1</sub> nAB	... the device is switched to the automatic mode.	The device has been configured or is in the manual mode
h3	No	Binary input BE1 or BE2 active	** .h FCT <sup>1)</sup> =h <sub>1</sub> nAB and binary function BIN1 or BIN2 on "On"	... the binary input is no longer active.	The contact connected to the binary input was active (e.g. packing gland monitoring, overpressure, temperature switch).
h4	Yes	The limit of stroke number exceeded	L.hSTRK≠OFF	... the stroke counter is reset or the thresholds are increased	The total path covered by the actuator exceeds one of the configured thresholds.
h5	Yes	Limit of changes of direction exceeded	O.hDCHG≠OFF	... the counter for changes of direction is reset or the thresholds are increased.	The number of changes of direction exceeds one of the configured thresholds.
h6	Yes	Limit of the lower hard end stop exceeded	F.hZERO≠OFF ** .YCLS = do or up do	... the deviation of the end stop disappears or the device is re-initialized.	Wear and tear of the valve seat, deposits or foreign bodies in the valve seat, mechanical misalignment, friction clutch moved.
h7	Yes	Limit of the upper hard end stop exceeded	G.hOPEN≠OFF ** .YCLS <sup>1)</sup> = do or up do	... the deviation of the end stop disappears or the device is re-initialized.	Wear and tear of the valve seat, deposits or foreign bodies in the valve seat, mechanical misalignment, friction clutch moved.
h8	No	Limit of deadband adjustment exceeded	E.hDEBA≠OFF ** .DEBA <sup>1)</sup> = Auto	... the limit is undershot again	Increased packing gland friction, mechanical gap in the position feedback.
h9	Yes	Partial-Stroke-Test exceeds reference stroke time	A.hPST≠OFF	... a Partial-Stroke-Test is successfully executed within the reference stroke time or the function is deactivated.	Valve jams or has rusted, increased friction
10	Yes	General control valve fault	b.hDEVI≠OFF	... the position is again in a narrow corridor between the reference variable and the model, or the function is deactivated.	Actuator fault, valve fault, valve jams, increased friction, decreased compressed air
11	Yes	Pneumatic leakage	C.hLEAK≠OFF	... the leakage drops below the configured thresholds, or the function is deactivated.	Pneumatic leakage

Error code	Three-stage	Event	Parameter setting	Error message disappears when	Possible causes
12	Yes	Static friction/ Slipstick effect occurs	d.4STIC#OFF	... Slipjumps can no longer be detected, or the function is deactivated.	Increased static friction, valve no longer moves smoothly, but with jerks
13	Yes	Temperature undershot	H.4TMIN#OFF	... the lower temperature thresholds are no longer undershot.	Ambient temperature too low
14	Yes	Temperature overshot	J.4TMAX#OFF	... the upper thresholds are no longer overshot.	Ambient temperature too high
15	Yes	Position average deviates from the reference value	P.4PAVG#OFF	... the position average calculated after a comparison interval is again within the thresholds for the reference value, or the function is deactivated.	In the last comparison interval, the valve trajectory was changed so severely that a deviating position average was calculated.

1)	Refer to the corresponding parameter descriptions for additional information about parameters
----	---

### See also

Overview of parameters 1 to 5 (Page 147)

Overview of parameters 6 to 51 (Page 148)

### 10.3.3 XDIAG parameter

You can use the advance diagnostics parameters to display fault messages in one, two or three stages. In addition to the fault message output, alarm outputs 1 and 2 are then used. For this purpose, set the "XDIAG" parameter as described in the following table:

Settings of XDIAG	Message due to
OFF	Advanced diagnostics not activated
On 1	Fault message output for threshold 3 fault messages (one-stage)
On 2	Fault message output for threshold 3 fault messages and alarm output 2 for threshold 2 fault messages (two-stage)
On 3	Fault message output for threshold 3 fault messages and alarm output 2 for threshold 2 fault messages and alarm output 1 for threshold 1 fault messages (three-stage)

Possible settings of the "XDIAG" parameter

## 10.3.4 Meaning of error codes

### 1 Monitoring of control deviation

The deviation between the setpoint and the actual value is continuously monitored in the automatic mode. The fault message for the remaining control deviation is activated depending on the setting of the "L<sub>1</sub>TIM" parameter, monitoring time for setting the fault messages and "L<sub>1</sub>LIM" and the response threshold. The fault message is cancelled as soon as the control deviation drops below the response threshold.

### 2 Automatic mode monitoring

When the device is not in automatic mode, a fault message is generated if the "L<sub>1</sub>FCT" parameter (function of fault message output) is set correctly. A warning is then sent to the control system if the device was switched to manual or configuration mode on-site.

### 3 Binary input BE1 or BE2 active

If the binary input is activated, a fault message is generated when the "L<sub>1</sub>FCT" parameter (function of fault message output) and the "BIN1" parameter (function of binary input 1) are set correctly. For example, it can be a switch to monitor the packing glands, a temperature switch or a limit switch (e.g. for pressure).

Binary input 2 (in the optional alarm module) can be configured in a similar manner.

### 4 Monitoring of the stroke number

### 5 Monitoring of the number of changes of direction

Both the values, namely the stroke number and the number of changes of direction are constantly compared with the thresholds that are determined from the parameters "L1.LIMIT" to "L4.FACT3" and "O1.LIMIT" to "O4.FACT3". If the thresholds are exceeded, the fault message output or the alarm outputs respond depending on the mode of the extended diagnostics. Both these functions can be deactivated using the parameter setting "OFF" for "L<sub>1</sub>.L<sub>1</sub>STRK" and "O<sub>1</sub>.L<sub>1</sub>DCHG".

### 6 Monitoring of the lower hard end stop (valve seat)

### 7 Monitoring of the upper hard end stop

If the parameter "F<sub>1</sub>.L<sub>1</sub>ZERO" is set to "ON", monitoring of the lower hard end stop is activated. This function can be used to detect the errors in the valve seat. An overshoot limit indicates the possibility of deposits or foreign bodies in the valve seat. An undershoot limit indicates probable wear and tear of the valve seat or flow restrictor. Even a mechanical misalignment of the position feedback can trigger this fault message.

Monitoring is always carried out whenever the valve is in the "down tight closing" position. The current position is compared with the position that was determined as the lower end stop at the time of initialization. The activation of "down tight closing" ("YCLS" parameter) is therefore the condition.

Example: A value of 3% is set. The position is normally adopted for "down tight closing". A fault is reported if a value  $> 3\%$  or  $< -3\%$  is determined instead.

The fault message remains activated until either a subsequent monitoring remains within the tolerance or a re-initialization process is executed. Even the deactivation of monitoring ("F.4 ZERO"=OFF) may trigger a fault message.

This monitoring function does not deliver any utilizable results if the end stops were not determined automatically at the time of initialization, but the limits were set manually (manual initialization, "5.INITM").

A similar diagnostics is carried out for the upper hard end stop. The "G.4OPEN" parameter is used to set the limit for this. The activation of "up tight closing" ("YCLS" parameter) is therefore the condition.

## 8 Monitoring of deadband adjustment

If the deadband increases disproportionately when adjusting it automatically ("DEBA"=Auto parameter), it indicates an error in the system (e.g. severely increased packing gland friction, play in the position displacement sensor, leakage). A limit can therefore be entered for this value ("E1.LEVL3", threshold for deadband monitoring). A fault message output is activated when this value is exceeded.

## 9 Partial stroke test exceeds the reference stroke time

On the one hand, this fault message appears when a manual or cyclic partial stroke test is initiated and the test cannot be started since the valve is not within the starting tolerance. On the other hand, this fault message appears when one of the three thresholds of the partial stroke test that are determined from the "A6.PSTIN" reference stroke time multiplied by factors "A7.FACT1" to "A9.FACT3" is violated. The degree of the fault message is shown in the number of columns on the display. The degree of the fault message is simultaneously displayed using the fault message output or alarm outputs depending on the mode of the extended diagnostics.

## 10 General control valve fault

The monitoring of the operational response responds when the actual valve position shifts from a narrow corridor between the reference variable and the expected position course. In this case, the deviation between the expected and actual position course is filtered, displayed and compared with the configured thresholds that are determined from the "b2.LIMIT" limit multiplied by the factors "b3.FACT1" to "b5.FACT3".

### **11 Pneumatic leakage**

This fault message appears when the leakage indicator exceeds the configured thresholds. Keep in mind that the complete sensitivity of this function can be used only if a ramp movement was initiated after initialization to set the leakage indicator (see explanations for "C1.LIMIT").

### **12 Static friction/slipstick effect is too large**

If the static friction of the control valve increases during operation or more Slipjumps are detected, it may exceed the corresponding limits and lead to this fault message.

### **13 Temperature undershot**

This fault message appears when the lower limit temperature thresholds are undershot.

### **14 Temperature overshoot**

This fault message appears when the upper limit temperature thresholds are overshoot.

### **15 Monitoring of the position average**

This fault message appears when a position value calculated after the expiry of a comparison interval deviates from the reference value by more than the configured thresholds.

### **See also**

Description of parameter C (Page 176)

## 10.4 Fault correction

### 10.4.1 Fault identification

#### Diagnostics guide

Fault	Remedial measures, see table			
<b>In which mode does a fault occur?</b>				
• Initialization	1			
• Manual and automatic modes	2	3	4	5
<b>In which environment and under which boundary conditions does a fault occur?</b>				
• Wet environment (e.g. strong rain or constant condensation)	2			
• Vibrating (oscillating) control valves	2	5		
• Impact or shock loads (e.g. vapor shocks or breakaway valves)	5			
• Moist (wet) compressed air	2			
• Dirty (contaminated with solid particles) compressed air	2	3		
<b>When does a fault occur?</b>				
• Regularly (reproducible)	1	2	3	4
• Sporadically (not reproducible)	5			
• Mostly after a specific operation time	2	3	5	

#### See also

Remedial measures table 1 (Page 214)

Remedial measures table 2 (Page 215)

Remedial measures table 3 (Page 216)

Remedial measures table 4 (Page 217)

Remedial measures table 5 (Page 218)

10.4.2 Remedial measures table 1

Fault profile (symptoms)	Possible cause(s)	Remedial measures
<ul style="list-style-type: none"> <li>Positioner remains in "RUN 1".</li> </ul>	<ul style="list-style-type: none"> <li>Initialization started from the end position and</li> <li>The response time of a maximum of 1 minute was not observed.</li> <li>Network pressure not connected or it is too low.</li> </ul>	<ul style="list-style-type: none"> <li>A waiting time of up to 1 minute is essential.</li> <li>Do not start initialization from the end position.</li> <li>Provide the network pressure.</li> </ul>
<ul style="list-style-type: none"> <li>Positioner remains in "RUN 2".</li> </ul>	<ul style="list-style-type: none"> <li>Transmission ratio selector and parameter 2</li> <li>"YAGL" and the real stroke do not match.</li> <li>Incorrectly set stroke on the lever.</li> <li>Piezo valve does not activate.</li> </ul>	<ul style="list-style-type: none"> <li>Check settings: see leaflet: "Device view (7)" picture as well as parameters 2 and 3</li> <li>Check the stroke setting on the lever. See table 2</li> </ul>
<ul style="list-style-type: none"> <li>Positioner remains in "RUN 3".</li> </ul>	<ul style="list-style-type: none"> <li>Actuator actuating time is too high.</li> </ul>	<ul style="list-style-type: none"> <li>Open the restrictor completely and/or set the pressure PZ (1) to the highest permissible value.</li> <li>Use a booster if required.</li> </ul>
<ul style="list-style-type: none"> <li>Positioner remains "RUN 5", does not go up to "FINISH" (waiting time &gt; 5 min).</li> </ul>	<ul style="list-style-type: none"> <li>"Gap" (play) in the positioner - actuator - control valve system</li> </ul>	<ul style="list-style-type: none"> <li>Part-turn actuator: check for the firmness of the grub screw of the coupling wheel</li> <li>Linear actuator: check for the firmness of the lever on the positioning shaft.</li> <li>Remove any play between the actuator and the control valve.</li> </ul>

Fault table 1

See also

Cleaning of the screens (Page 220)

Operation with boosters (Page 255)



## 10.4.3 Remedial measures table 2

Fault profile (symptoms)	Possible cause(s)	Remedial measures
<ul style="list-style-type: none"> <li>"CPU test" blinks on the display approximately every 2 seconds.</li> <li>Piezo valve does not activate.</li> </ul>	<ul style="list-style-type: none"> <li>Water in the pneumatic block (due to wet compressed air)</li> </ul>	<ul style="list-style-type: none"> <li>At an early stage, this fault can be rectified with a subsequent operating using dry air, if required, in a temperature cabinet at 50 to 70°C.</li> <li>Otherwise: Repair</li> </ul>
<ul style="list-style-type: none"> <li>In the manual and automatic modes, the actuator cannot be moved or can be moved only in one direction.</li> </ul>	<ul style="list-style-type: none"> <li>Moisture in the pneumatic block</li> </ul>	
<ul style="list-style-type: none"> <li>Piezo valve does not activate (a gentle click sound is not audible when the "+" or "-" buttons are pressed in the manual mode.)</li> </ul>	<ul style="list-style-type: none"> <li>The screw between the shrouding cover and the pneumatic block has not been tightened firmly or the cover got stuck.</li> </ul>	<ul style="list-style-type: none"> <li>Tighten the screw firmly; if required, rectify the deadlock.</li> </ul>
	<ul style="list-style-type: none"> <li>Dirt (swarf, particles) in the pneumatic block</li> </ul>	<ul style="list-style-type: none"> <li>Repair or a new device; clean and/or replace the built-in fine screens.</li> </ul>
	<ul style="list-style-type: none"> <li>Deposits on the contacts between the electronic printed circuit board and the pneumatic block may develop due to abrasion owing to continuous loads resulting from strong vibrations.</li> </ul>	<ul style="list-style-type: none"> <li>Clean all contact surfaces with spirit; if required, bend the pneumatic block contact springs.</li> </ul>

Fault table 2

**See also**

Repair/Upgrading (Page 221)

### 10.4.4 Remedial measures table 3

Fault profile (symptoms)	Possible cause	Remedial measures
<ul style="list-style-type: none"> <li>Actuator does not move.</li> </ul>	<ul style="list-style-type: none"> <li>Compressed air &lt; 1.4 bar</li> </ul>	<ul style="list-style-type: none"> <li>Set the supply air pressure to &gt; 1.4 bar.</li> </ul>
<ul style="list-style-type: none"> <li>Piezo valve does not activate (a gentle click sound is however audible when the "+" or "-" buttons are pressed in the manual mode.)</li> </ul>	<ul style="list-style-type: none"> <li>Restrictor valve turned off (screw at the right end stop)</li> </ul>	<ul style="list-style-type: none"> <li>Open the restrictor screw by turning it anticlockwise, see leaflet, "Device view (6)".</li> </ul>
	<ul style="list-style-type: none"> <li>Dirt in the pneumatic block</li> </ul>	<ul style="list-style-type: none"> <li>Repair or a new device; clean and/or replace the built-in fine screens.</li> </ul>
<ul style="list-style-type: none"> <li>A piezo valve activates constantly in the stationary automatic mode (constant setpoint) and the manual mode.</li> </ul>	<ul style="list-style-type: none"> <li>Pneumatic leakage in the positioner - actuator system; start the leakage test in "RUN 3" (initialization).</li> </ul>	<ul style="list-style-type: none"> <li>Rectify leakage in the actuator and/or feed line.</li> <li>In case of an intact actuator and tight feed line: Repair or new device</li> </ul>
	<ul style="list-style-type: none"> <li>Dirt in the pneumatic block, see above</li> </ul>	<ul style="list-style-type: none"> <li>See above</li> </ul>

Fault table 3

**See also**

Repair/Upgrading (Page 221)

## 10.4.5 Remedial measures table 4

Symptoms	Possible cause(s)	Remedial measures
<ul style="list-style-type: none"> <li>In stationary automatic mode (constant setpoint) and in manual mode, both piezo valves continually switch alternately, and the actuator oscillates around a mean value.</li> </ul>	<ul style="list-style-type: none"> <li>Sticking friction of the packing gland from the control valve or actuator too large</li> </ul>	<ul style="list-style-type: none"> <li>Reduce friction or increase dead zone of positioner (parameter "dEbA") until the oscillation stops.</li> </ul>
	<ul style="list-style-type: none"> <li>Looseness (play) in the positioner/actuator/control valve system</li> </ul>	<ul style="list-style-type: none"> <li>Part-turn actuator: Check for firm seating of set screw on coupling wheel.</li> <li>Linear actuator: Check for firm seating of lever on positioner shaft.</li> <li>Correct any other play between the actuator and the control valve.</li> </ul>
	<ul style="list-style-type: none"> <li>Actuator too fast</li> </ul>	<ul style="list-style-type: none"> <li>Increase actuating times using throttle screws.</li> <li>If a quick actuating time is needed, increase the dead zone (parameter "dEbA") until the oscillation stops.</li> </ul>
<ul style="list-style-type: none"> <li>Positioner doesn't move control valve to the stop (at 20 mA).</li> </ul>	<ul style="list-style-type: none"> <li>Supply pressure too low. Load on the feeding controller or system output is too low.</li> </ul>	<ul style="list-style-type: none"> <li>Increase supply pressure, insert ballast converter</li> <li>Select 3/4-wire mode</li> </ul>

Error table 4

**See also**

Cleaning of the screens (Page 220)

### 10.4.6 Remedial measures table 5

Fault profile (symptoms)	Possible cause(s)	Remedial measures
<ul style="list-style-type: none"> <li>Zero point displaces sporadically (&gt; 3%).</li> </ul>	<ul style="list-style-type: none"> <li>Impact or shock loads result in accelerations so high that the friction clutch moves, e.g. due to "vapor shocks" in vapor lines.</li> </ul>	<ul style="list-style-type: none"> <li>Rectify the causes for shock loads.</li> <li>Re-initialize the position controller.</li> </ul>
<ul style="list-style-type: none"> <li>The device function has completely failed: no view even on the digital display.</li> </ul>	<ul style="list-style-type: none"> <li>Electrical auxiliary power supply is not adequate.</li> </ul>	<ul style="list-style-type: none"> <li>Check the electrical auxiliary power supply.</li> </ul>
	<ul style="list-style-type: none"> <li>In case of very high continuous loads due to vibrations (oscillations):</li> <li>Screws of the electrical connecting terminals may be loosened.</li> <li>Electrical connecting terminals and/or electronic components may be knocked out.</li> </ul>	<ul style="list-style-type: none"> <li>Tighten the screws firmly and secure using sealing wax.</li> <li>Repair</li> <li>For prevention: Install the positioner on the damping pads.</li> </ul>

Fault table 5

**See also**

Repair/Upgrading (Page 221)

## 11.1 Basic safety instructions

 <b>WARNING</b>
<b>Impermissible repair of the device</b> <ul style="list-style-type: none"><li>• Repair must be carried out by Siemens authorized personnel only.</li></ul>

 <b>WARNING</b>
<b>Impermissible accessories and spare parts</b> <p>Danger of explosion in areas subject to explosion hazard.</p> <ul style="list-style-type: none"><li>• Only use original accessories or original spare parts.</li><li>• Observe all relevant installation and safety instructions described in the instructions for the device or enclosed with the accessory or spare part.</li></ul>

<b>NOTICE</b>
<b>Penetration of moisture into the device</b> <p>Device damage.</p> <ul style="list-style-type: none"><li>• Make sure when carrying out cleaning and maintenance work that no moisture penetrates the inside of the device.</li></ul>

 <b>CAUTION</b>
<b>Releasing key lock</b> <p>Improper modification of parameters could influence process safety.</p> <ul style="list-style-type: none"><li>• Make sure that only authorized personnel may cancel the key locking of devices for safety-related applications.</li></ul>

 <b>WARNING</b>
<b>Electrostatic charge</b> <p>Danger of explosion in hazardous areas if electrostatic charges develop, for example, when cleaning plastic enclosures with a dry cloth.</p> <ul style="list-style-type: none"><li>• Prevent electrostatic charging in hazardous areas.</li></ul>

 **WARNING**

**Dust layers above 5 mm**

Danger of explosion in hazardous areas. Device may overheat due to dust build up.

- Remove any dust layers in excess of 5 mm.

### Cleaning the enclosure

- Clean the outside of the enclosure and the display window using a cloth moistened with water or a mild detergent.
- Do not use aggressive cleaning agents or solvents. Plastic components or painted surfaces could be damaged.

## 11.2 Cleaning of the screens

The positioner is maintenance-free to a large extent. Screens are installed in the pneumatic connections of the positioners to protect them from rough dirt particles. If there are dirt particles in the pneumatic auxiliary power supply, they damage the screens and hamper the function of the positioner. Clean the screens as described in the following two chapters.

### 11.2.1 Positioner in macrolon enclosure

 **DANGER**

**Risk of explosion due to electrostatic charge**

Electrostatic charges develop when cleaning the positioner in the macrolon enclosure with a dry cloth, for example.

It is imperative you avoid electrostatic charges in the hazardous environment.

### Removal and cleaning of the screens

1. Disconnect the pneumatic auxiliary power supply.
2. Remove the lines.
3. Unscrew the cover.
4. Unscrew the three self-tapping screws on the pneumatic terminal strip.
5. Remove the screens and O-rings behind the terminal strip.
6. Clean the screens, e.g. using compressed air.

## Installation of the screens

** CAUTION****Damage to the enclosure**

- The enclosure is damaged due to screwing in the self-tapping screws improperly.
- Ensure that the available thread pitches are used.
- Turn the screws anticlockwise until they engage noticeably in the thread pitch.
- Tighten the self-tapping screws only after they have engaged.

1. Insert the screens into the recesses of the macrolon enclosure.
2. Place the O-rings on the screens.
3. Fit the pneumatic terminal strip on both studs so that it fits flushly.
4. Screw-on the three self-tapping screws.
5. Place the cover and tighten it.
6. Reconnect the pipelines and feed the pneumatic power supply.

### 11.2.2 Positioner in stainless steel, aluminum and flameproof aluminum enclosure

#### Removal, cleaning and installation of the screens

1. Disconnect the pneumatic auxiliary power supply.
2. Remove the pipelines.
3. Remove the metal screen from the bores carefully.
4. Clean the metal screens, e.g. using compressed air.
5. Insert the screens.
6. Connect the pipelines again.
7. Feed the pneumatic auxiliary power supply.

## 11.3 Repair/Upgrading

Send defective devices to the repairs department, together with information on the malfunction and the cause of the malfunction. When ordering replacement devices, please provide the serial number of the original device. You can find the serial number on the nameplate.

#### See also

Technical support (Page 257)

## 11.4 Return procedure

Enclose the bill of lading, return document and decontamination certificate in a clear plastic pouch and attach it firmly to the outside of the packaging.

### Required forms

- Delivery note
- Return document (<http://www.siemens.com/processinstrumentation/returngoodsnote>)  
with the following information:
  - Product (item description)
  - Number of returned devices/replacement parts
  - Reason for returning the item(s)
- Decontamination declaration (<http://www.siemens.com/sc/declarationofdecontamination>)

With this declaration you warrant "that the device/replacement part has been carefully cleaned and is free of residues. The device/replacement part does not pose a hazard for humans and the environment."

If the returned device/replacement part has come into contact with poisonous, corrosive, flammable or water-contaminating substances, you must thoroughly clean and decontaminate the device/replacement part before returning it in order to ensure that all hollow areas are free from hazardous substances. Check the item after it has been cleaned.

Any devices/replacement parts returned without a decontamination declaration will be cleaned at your expense before further processing.

The forms can be found on the Internet as well as in the documentation which comes with the device.

### See also

Decontamination declaration (<http://www.siemens.com/sc/declarationofdecontamination>)



## Technical data

### 12.1 Rated conditions

<b>Rated conditions</b>	
Ambient temperature	In hazardous areas, observe the maximum permissible ambient temperature corresponding to the temperature class.
<ul style="list-style-type: none"> <li>Permissible ambient temperature for operation</li> </ul>	-30 ... +80 °C (-22 ... +176°F)
Degree of protection <sup>1)</sup>	IP66 to EN 60529/NEMA 4X
Mounting position	Any; in wet environment, pneumatic connections and outlet opening not upward
<b>Vibration resistance</b>	
<ul style="list-style-type: none"> <li>Harmonic oscillations (sine) according to EN 60068-2-6/10.2008</li> </ul>	3.5 mm (0.14"), 2 ... 27 Hz, 3 cycles/axle 98.1 m/s <sup>2</sup> (321.84 ft/s <sup>2</sup> ), 27 ... 300 Hz, 3 cycles/axle
<ul style="list-style-type: none"> <li>Bumping (half-sine) according to EN 60068-2-27/02.2010</li> </ul>	150 m/s <sup>2</sup> (492 ft/s <sup>2</sup> ), 6 ms, 1000 shocks/axle
<ul style="list-style-type: none"> <li>Noise (digitally controlled) according to EN 60068-2-64/04.2009</li> </ul>	10 ... 200 Hz; 1 (m/s <sup>2</sup> ) <sup>2</sup> /Hz (3.28 (ft/s <sup>2</sup> ) <sup>2</sup> /Hz) 200 ... 500 Hz; 0.3 (m/s <sup>2</sup> ) <sup>2</sup> /Hz (0.98 (ft/s <sup>2</sup> ) <sup>2</sup> /Hz) 4 hours/axle
<ul style="list-style-type: none"> <li>Recommended range of continuous operation of the entire control valve</li> </ul>	≤ 30 m/s <sup>2</sup> (98.4 ft/s <sup>2</sup> ) without resonance peak
<b>Climate class</b>	
<ul style="list-style-type: none"> <li>Storage</li> </ul>	1K5, but -40 ... +80°C (1K5, but -40 ... +176°F)
<ul style="list-style-type: none"> <li>Transport</li> </ul>	2K4, but -40 ... +80°C (2K4, but -40 ... +176°F)
<ul style="list-style-type: none"> <li>Operation <sup>2)</sup></li> </ul>	4K3, but -30 to +80 °C (4K3, but -22 to +176 °F) <sup>3)</sup>

<sup>1)</sup> Max. impact energy 1 Joule for enclosure with inspection window 6DR5..0 and 6DR5..1.

<sup>2)</sup> At ≤ -10 °C (≤ 14 °F), the display refresh rate is limited. In the case of use with IyModule, only T4 is permissible.

<sup>3)</sup> -20 to +80 °C (-4 to +176 °F) for 6DR55..-0G ..., 6DR56..-0G ..., 6DR55..-0D ... and 6DR56..-0D...

## 12.2 Pneumatic data

<b>Pneumatic data</b>	
Auxiliary power (air supply)	Compressed air, carbon dioxide (CO <sub>2</sub> ), nitrogen (N), noble gases or cleaned natural gas
• Pressure	1,4 ... 7 bar (20.3 ... 101.5 psi)
Air quality to ISO 8573-1	
• Solid particulate size and density	Class 2
• Pressure dew point	Class 2 (min. 20 K (36°F) below ambient temperature)
• Oil content	Class 2
Unrestricted flow (DIN 1945)	
• Inlet air valve (ventilate actuator) <sup>1)</sup>	
2 bar (29 psi)	4.1 Nm <sup>3</sup> /h (18.1 USgpm)
4 bar (58 psi)	7.1 Nm <sup>3</sup> /h (31.3 USgpm)
6 bar (87 psi)	9.8 Nm <sup>3</sup> /h (43.1 USgpm)
• Air exhaust valve (depressurize drive) <sup>1)</sup>	
2 bar (29 psi)	8.2 Nm <sup>3</sup> /h (36.1 USgpm)
4 bar (58 psi)	13.7 Nm <sup>3</sup> /h (60.3 USgpm)
6 bar (87 psi)	19.2 Nm <sup>3</sup> /h (84.5 USgpm)
Valve leakage	< 6·10 <sup>-4</sup> Nm <sup>3</sup> /h (0.0026 USgpm)
Throttle ratio	Adjustable up to ∞: 1
Auxiliary power consumption in the controlled state	< 3,6·10 <sup>-2</sup> Nm <sup>3</sup> /h (0.158 USgpm)

<sup>1)</sup> When using device version Ex d (6DR5..5-...), values are reduced by approximately 20%.

## 12.3 Construction

Construction	
How does it work?	
• Range of stroke (linear actuator)	3 ... 130 mm (0.12 ... 5.12") (angle of positioner shaft 16 ... 90°)
• Angle of rotation (part-turn actuator)	30 ... 100°
Mounting method	
• On the linear actuator	Using mounting kit 6DR4004-8V and, where necessary, an additional lever arm 6DR4004-8L on actuators according to IEC 60534-6-1 (NAMUR) with rib, bars or flat face.
• On the part-turn actuator	Using mounting kit 6DR4004-8D on actuators with mounting plane according to VDI/VDE 3845 and IEC 60534-6-2: The required mount must be provided on the actuator-side.
Weight, basic device	
• Glass-fiber reinforced polycarbonate housing	Approx. 0.9 kg (1.98 lb)
• Aluminum enclosure	Approx. 1.3 kg (2.86 lb)
• Stainless steel enclosure	Approx. 3.9 kg (8.6 lb)
• Flameproof aluminum enclosure	Approx. 5.2 kg (11.46 lb)
Material	
• Enclosure	
6DR5..0-... (macrolon)	Glass-fiber reinforced polycarbonate (PC)
6DR5..1-... (aluminum)	GD AISi12
6DR5..2-... (stainless steel)	Austenitic stainless steel mat. No. 1.4581
6DR5..5-... (aluminum, flameproof)	GK AISi12
• Pressure gauge block	Aluminum AlMgSi, anodized
Versions	
• In macrolon enclosure	Single-acting and double-acting
• In the aluminum enclosure	Single-acting
• In flameproof aluminum enclosure	Single-acting and double-acting
• In the stainless steel enclosure	Single-acting and double-acting
Torques	
• Part-turn actuator fixing screws DIN 933 M6x12-A2	5 Nm (3.7 ft lb)
• Linear actuator fixing screws DIN 933 M8x16-A2	12 Nm (8.9 ft lb)



## 12.4 Electrical data

	Basic device without explosion protection	Basic device with explosion protection Ex d	Basic device with explosion protection Ex "ia"	Basic device with explosion protection Ex "ic", "nA", "t"
<b>Current input I<sub>w</sub></b>				
• Rated signal range	0/4 ... 20 mA			
• Load voltage at 20 mA	≤ 0.2 V (= 10 Ω)	≤ 0.2 V (= 10 Ω)	≤ 1 V (= 50 Ω)	≤ 1 V (= 50 Ω)
• Test voltage	DC 840 V, 1 s			
• Binary input BE1 (terminals 9/10; galvanically connected to basic device)	Suitable only for floating contact; max. contact load < 5 μA with 3 V			
<b>2-wire connection</b> (terminals 6/8) 6DR50.. and 6DR53.. Without HART 6DR51.. and 6DR52.. With HART				
Current to maintain the auxiliary power supply	≥ 3,6 mA			
Required load voltage U <sub>B</sub> (corresponds to Ω at 20 mA)				
• Without HART (6DR50..)				
Typical	6.36 V (= 318 Ω)	6.36 V (= 318 Ω)	7.8 V (= 390 Ω)	7.8 V (= 390 Ω)
Max.	6.48 V (= 324 Ω)	6.48 V (= 324 Ω)	8.3 V (= 415 Ω)	8.3 V (= 415 Ω)
• Without HART (6DR53..)				
Typical	7.9 V (= 395 Ω)	-	-	-
Max.	8.4 V (= 420 Ω)	-	-	-
• With HART (6DR51..)				
Typical	6.6 V (= 330 Ω)	6.6 V (= 330 Ω)	-	-
Max.	6.72 V (= 336 Ω)	6.72 V (= 336 Ω)	-	-
• With HART (6DR52..)				
Typical	-	8.4 V (= 420 Ω)	8.4 V (= 420 Ω)	8.4 V (= 420 Ω)
Max.	-	8.8 V (= 440 Ω)	8.8 V (= 440 Ω)	8.8 V (= 440 Ω)
• Static destruction limit	± 40 mA	± 40 mA	-	-
Effective inner capacitance C <sub>i</sub>				
• Without HART	-	-	22 nF	"ic": 22 nF
• With HART	-	-	7 nF	"ic": 7 nF
Effective inner inductance L <sub>i</sub>				
• Without HART	-	-	0.12 mH	"ic": 0.12 mH

Technical data

12.4 Electrical data

	Basic device without explosion protection	Basic device with explosion protection Ex d	Basic device with explosion protection Ex "ia"	Basic device with explosion protection Ex "ic", "nA", "t"
• With HART	-	-	0.24 mH	"ic": 0.24 mH
For connecting to circuits with the following peak values	-	-	U <sub>n</sub> = DC 30 V I <sub>i</sub> = 100 mA P <sub>i</sub> = 1 W	"ic": U <sub>i</sub> = 30 V I <sub>i</sub> = 100 mA "nA"/"t": U <sub>n</sub> ≤ 30 V I <sub>n</sub> ≤ 100 mA
<b>3-4-wire connection</b> (terminals 2/4 and 6/8) 6DR52.. With HART, explosion-protected 6DR53.. Without HART, not explosion-protected				
Auxiliary power supply U <sub>H</sub>	DC 18 ... 35 V	DC 18 ... 35 V	DC 18 ... 30 V	DC 18 ... 30 V
• Current consumption I <sub>H</sub>	(V <sub>H</sub> - 7.5 V)/2.4 kΩ [mA]			
For connecting to circuits with the following peak values	-	-	U <sub>n</sub> = 30 V I <sub>i</sub> = 100 mA P <sub>i</sub> = 1 W C <sub>i</sub> = 22 nF L <sub>i</sub> = 0.12 mH	"ic": U <sub>i</sub> = 30 V I <sub>i</sub> = 100 mA C <sub>i</sub> = 22 nF L <sub>i</sub> = 0.12 mH "nA"/"t": U <sub>n</sub> ≤ 30 V I <sub>n</sub> ≤ 100 mA
Galvanic isolation	Between U <sub>H</sub> and I <sub>w</sub>	Between U <sub>H</sub> and I <sub>w</sub>	Between U <sub>H</sub> and I <sub>w</sub> (2 intrinsically safe circuits)	Between U <sub>H</sub> and I <sub>w</sub>

## 12.5 Controller

Controller	
Control unit	
• Five-point controller	Adaptive
• Dead zone	
dEbA = auto	Adaptive or can be preset
dEbA = 0.1 ... 10 %	Adaptive or can be preset
Analog-to-digital converter	
• Scanning time	10 ms
• Resolution	≤ 0.05 %
• Transmission error	≤ 0.2 %
• Temperature influence	≤ 0.1 %/10 K (≤ 0.1 %/18 °F)
Cycle time	
• 20 mA/HART device	20 ms
• PA device	60 ms
• FF device	60 ms (min. loop time)





## 12.6 Certificates, approvals, explosion protection for all device versions

Certificates and approvals	
Classification according to pressure equipment directive (PED 97/23/EC)	For fluid group 1 gases; fulfills requirements in article 3, paragraph 3 (good engineering practice SEP)
CE conformity	The applicable directives and standards applied with their revision levels can be found in the EC declaration of conformity on the Internet.

Explosion protection	Ex markings	
Explosion protection in accordance with	ATEX/IECEX	FM/CSA
Flameproof enclosure "d"	Zone 1:  II 2 G Ex d IIC T6/T4 Gb	FM: XP, Class I, Division 1, ABCD XP, Class I, Zone 1, AEx d, IIC, T6/T4 CSA: Class I, Division 1, Groups CD Class II/III, Division 1, Groups EFG

Technical data

12.6 Certificates, approvals, explosion protection for all device versions

Explosion protection	Ex markings	
Intrinsic safety "ia"	Zone 1:  II 2 G Ex ia IIC T6/T4 Gb  II 2 D Ex ia IIIC 110°C Db	FM: IS, Class I, Division 1, ABCD Class I, Zone 1, AEx ib, IIC, T6/T4 CSA: Class I, Division 1, ABCD Class I, Zone 1, Ex ib, IIC
Intrinsic safety "ic"	Zone 2:  II 3 G Ex ic IIC T6/T4 Gc	-
Non-sparking, energy-limited "nA"	Zone 2:  II 3 G Ex nA IIC T6/T4 Gc	FM: NI, Class I, Division 2, ABCD NI, Class I, Zone 2, IIC, T6/T4 CSA: Class I, Division 2, ABCD Class I, Zone 2, IIC
Dust, protection by enclosure "t"	Zone 22:  II 3 D Ex tb IIIC T100°C Dc IP66	CSA: Class II, Division 1
<b>Permissible ambient temperature</b>		
<ul style="list-style-type: none"> <li>For operation with or without HART <sup>1)</sup></li> </ul>	Zones 1, 2 and 22 T4: -30 ... +80 °C (-22 ... +176 °F) T6: -30 ... +50 °C (-22 ... +122 °F)	
<ul style="list-style-type: none"> <li>For operation with PROFIBUS PA or with FOUNDATION Fieldbus <sup>1)</sup></li> </ul>	Zone 1 T4: -30 ... +80 °C (-22 ... +176 °F) T6: -30 ... +50 °C (-22 ... +122 °F) Zones 2 and 22 T4: -20 ... +75 °C (-4 ... +103 °F) T6: -20 ... +50 °C (-4 ... +122 °F)	

<sup>1)</sup> At ≤ -10 °C (+14 °F), the display refresh rate of the display is limited. For basic devices with explosion protection: When using ly module, only T4 is permissible.



## 12.7 Technical data for natural gas as actuator medium

### Introduction

Note when using an actuator with natural gas that this can escape at the following points:

- At the exhaust air outlet with a sound absorber at the bottom of the device.
- At the enclosure ventilation at the bottom of the device.
- At the control air outlet near the pneumatic connections.

---

#### Note

##### Exhaust air outlet with a sound absorber at the bottom of the device

The positioner is delivered as standard with a sound absorber at the bottom of the device. To provide an outlet for the exhaust air, replace the sound absorber by a G¼ pipe coupling.

##### Enclosure ventilation and control air outlet

Enclosure ventilation and control air outlet cannot be collected and channeled off.

---

Please refer to the following table for the maximum bleeding values.

### Maximum values for escaping natural gas

Bleeding process	Operating mode	6DR5.1.-E...	6DR5.2.-E...
		Single-acting	Double-acting
		[NI/min]	[NI/min]
Ventilation of enclosure volume via bottom of device. Purge air switch is at "IN":	Operation, typical	0.14	0.14
	Operation, max.	0.60	0.60
	Error case, max.	60.0	60.0
Bleed through the control air outlet near the pneumatic connections:	Operation, typical	1.0	2.0
	Operation, max.	8.9	9.9
	Error case, max.	66.2	91.0
Ventilation via the exhaust air outlet with a sound absorber at the bottom of the device	Operation, max.	358.2 <sup>1)</sup>	339 <sup>1)</sup>
	Error case, max.		
Volume	Max. [l]	1.26	1.23

1) Depending on the actuating pressure and volume of the actuator as well as the frequency of control. The maximum flow rate is 470 NI/min at a differential pressure of 7 bar.

### See also

Basic safety instructions (Page 111)

Pneumatic connection on the standard controller (Page 95)

## 12.8 Option modules

### 12.8.1 Alarm module

	Without Ex protection/ with Ex protection Ex d	With Ex protection Ex "ia"	With Ex protection Ex "ic", "nA", "t"
<b>Alarm module</b>	6DR4004-8A	6DR4004-6A	6DR4004-6A
3 binary output circuits			
<ul style="list-style-type: none"> <li>Alarm output A1: Terminals 41 and 42</li> <li>Alarm output A2: Terminals 51 and 52</li> <li>Fault message output: Terminals 31 and 32</li> </ul>			
• Auxiliary voltage $U_H$	$\leq 35\text{ V}$	-	-
• Signal status			
High (not addressed)	Conductive, $R = 1\text{ k}\Omega$ , $+3/-1\% *$	$\geq 2.1\text{ mA}$	$\geq 2.1\text{ mA}$
Low *) (addressed)	Deactivated, $I_R < 60\text{ }\mu\text{A}$	$\leq 1.2\text{ mA}$	$\leq 1.2\text{ mA}$
*) The status is also Low if the basic device is faulty or without a auxiliary power.	*) When using in the flameproof housing, the current consumption must be restricted to 10 mA per output.	Switching thresholds for supply as per EN 60947-5-6: $U_H = 8.2\text{ V}$ , $R_i = 1\text{ k}\Omega$	Switching thresholds for supply as per EN 60947-5-6: $U_H = 8.2\text{ V}$ , $R_i = 1\text{ k}\Omega$
• For connecting to circuits with the following peak values	-	$U_i = \text{DC } 15.5\text{ V}$ $I_i = 25\text{ mA}$ $P_i = 64\text{ mW}$ $C_i = 5,2\text{ nF}$ $L_i = \text{negligibly small}$	"ic": $U_i = \text{DC } 15.5\text{ V}$ $I_i = 25\text{ mA}$ $C_i = 5,2\text{ nF}$ $L_i = \text{negligibly small}$ "nA"/"t": $U_n \leq \text{DC } 15.5\text{ V}$
1 binary input circuit			
<ul style="list-style-type: none"> <li>Binary input BE2: Terminals 11 and 12, terminals 21 and 22 (jumper)</li> </ul>			
• Galvanically connected with the basic device			
Signal status 0	Floating contact, open		
Signal status 1	Floating contact, closed		
Contact load	3 V, 5 $\mu\text{A}$		
• Electrically isolated from the basic device			
Signal status 0	$\leq 4.5\text{ V}$ or open		
Signal status 1	$\geq 13\text{ V}$		
Internal resistance	$\geq 25\text{ k}\Omega$		

	Without Ex protection/ with Ex protection Ex d	With Ex protection Ex "ia"	With Ex protection Ex "ic", "nA", "t"
• Static destruction limit	± 35 V	-	-
• Connecting to circuits with the following peak values	-	U <sub>i</sub> = DC 25.2 V C <sub>i</sub> = negligibly small L <sub>i</sub> = negligibly small	"ic": U <sub>i</sub> = DC 25.2 V C <sub>i</sub> = negligibly small L <sub>i</sub> = negligibly small "n"/"t": U <sub>n</sub> ≤ DC 25.5 V
Galvanic isolation	The three outputs, the BE2 input and the basic device are galvanically isolated from each other.		
Test voltage	DC 840 V, 1 s		

## 12.8.2 I<sub>y</sub> module

	Without Ex protection/ with Ex protection Ex d	With Ex protection Ex ia (only in temperature class T4)	With Ex protection Ex "ic", "nA", "t"
<b>I<sub>y</sub> module</b>	6DR4004-8J	6DR4004-6J	6DR4004-6J
Direct current output for position feedback			
1 current output, terminals 61 and 62	2-wire connection		
Rated signal range	4 ... 20 mA, short-circuit proof		
Dynamic range	3.6 ... 20.5 mA		
Auxiliary voltage U <sub>H</sub>	+12 ... +35 V	+12 ... +30 V	+12 ... +30 V
External load R <sub>B</sub> [kΩ]	≤ (U <sub>H</sub> [V] - 12 V)/i [mA]		
Transmission error	≤ 0.3%		
Temperature influence	≤ 0.1%/10 K (≤ 0.1%/18 °F)		
Resolution	≤ 0.1%		
Residual ripple	≤ 1 %		
For connecting to circuits with the following peak values		U <sub>i</sub> = DC 30 V I <sub>i</sub> = 100 mA P <sub>i</sub> = 1 W C <sub>i</sub> = 11 nF L <sub>i</sub> = negligibly small	"ic": U <sub>i</sub> = DC 30 V I <sub>i</sub> = 100 mA C <sub>i</sub> = 11 nF L <sub>i</sub> = negligibly small "nA"/"t": U <sub>n</sub> ≤ DC 30 V I <sub>n</sub> ≤ 100 mA P <sub>n</sub> ≤ 1 W
Galvanic isolation	Safe galvanic isolation from alarm option and basic device		
Test voltage	DC 840 V, 1 s		

### 12.8.3 SIA module

	Without explosion protection	With Ex protection Ex "ia"	With Ex protection Ex "ic", "nA", "t"
<b>SIA module</b>	6DR4004-8G	6DR4004-6G	6DR4004-6G
Limit encoder with slotted initiators and fault message output			
2 slotted initiators			
<ul style="list-style-type: none"> <li>Binary output (limit transmitter) A1: Terminals 41 and 42</li> <li>Binary output (limit transmitter) A2: Terminals 51 and 52</li> </ul>			
2-wire connection			
• Connection	2 wire technology in accordance with EN 60947-5-6 (NAMUR), for switching amplifiers connected on load side		
• Signal state Low (triggered)	< 1.2 mA		
• 2 slotted initiators	Type SJ2-SN		
• Function	NC contact (NC, normally closed)		
• Connecting to circuits with the following peak values	Nominal voltage 8 V; current consumption: ≥ 3 mA (limit not activated), ≤ 1 mA (limit activated)	U <sub>i</sub> = DC 15 V I <sub>i</sub> = 25 mA P <sub>i</sub> = 64 mW C <sub>i</sub> = 41 nF L <sub>i</sub> = 100 µH	"ic": U <sub>i</sub> = DC 15 V I <sub>i</sub> = 25 mA C <sub>i</sub> = 41 nF L <sub>i</sub> = 100 µH "nA": U <sub>n</sub> ≤ DC 15 V P <sub>n</sub> ≤ 64 mW
1 fault message output			
<ul style="list-style-type: none"> <li>Binary output: Terminals 31 and 32</li> </ul>			
• Connection	At switching amplifier in accordance with EN 60947-5-6: (NAMUR), U <sub>H</sub> = 8.2 V, R <sub>i</sub> = 1 kΩ).		
• Signal state High (not triggered)	R = 1.1 kΩ	> 2.1 mA	> 2.1 mA
• Signal state Low (triggered)	R = 10 kΩ	< 1.2 mA	< 1.2 mA
• Auxiliary power supply U <sub>H</sub>	U <sub>H</sub> ≤ DC 35 V I ≤ 20 mA	-	-
• Connecting to circuits with the following peak values	-	U <sub>i</sub> = DC 15 V I <sub>i</sub> = 25 mA P <sub>i</sub> = 64 mW C <sub>i</sub> = 5.2 nF L <sub>i</sub> = negligibly small	"ic": U <sub>i</sub> = DC 15 V I <sub>i</sub> = 25 mA C <sub>i</sub> = 5.2 nF L <sub>i</sub> = negligibly small "nA": U <sub>n</sub> ≤ DC 15 V P <sub>n</sub> ≤ 64 mW
Galvanic isolation	The 3 outputs are galvanically isolated from the basic device.		
Test voltage	DC 840 V, 1 s		

## 12.8.4 Limit value contact module

	Without Ex protection	With Ex protection Ex ia	With Ex protection Ex "ic", "nA", "t"
<b>Limit contact module</b>	6DR4004-8K	6DR4004-6K	6DR4004-6K
Limit encoder with mechanical switching contacts			
2 limit contacts			
<ul style="list-style-type: none"> <li>• 1 binary output: Terminals 41 and 42</li> <li>• 2 binary output: Terminals 51 and 52</li> </ul>			
• Max. switching current AC/DC	4 A	-	-
• For connecting to circuits with the following peak values	-	$U_i = \text{DC } 30 \text{ V}$ $I_i = 100 \text{ mA}$ $P_i = 750 \text{ mW}$ $C_i, L_i = \text{negligibly small}$	"ic": $U_i = \text{DC } 30 \text{ V}$ $I_i = 100 \text{ mA}$ $C_i, L_i = \text{negligibly small}$ "nA": $U_n \leq \text{DC } 15 \text{ V}$
• Max. switching voltage AC/DC	250 V/24 V	DC 30 V	DC 30 V
1 fault message output			
<ul style="list-style-type: none"> <li>• Binary output: Terminals 31 and 32</li> </ul>			
• Connection	At switching amplifier in accordance with EN 60947-5-6: (NAMUR), $U_H = 8.2 \text{ V}$ , $R_i = 1 \text{ k}\Omega$ .		
• Signal state High (not triggered)	$R = 1.1 \text{ k}\Omega$	$> 2.1 \text{ mA}$	$> 2.1 \text{ mA}$
• Signal state Low (triggered)	$R = 10 \text{ k}\Omega$	$< 1.2 \text{ mA}$	$< 1.2 \text{ mA}$
• Auxiliary power	$U_H \leq \text{DC } 35 \text{ V}$ $I \leq 20 \text{ mA}$	-	-
• Connecting to circuits with the following peak values	-	$U_i = 15 \text{ V}$ $I_i = 25 \text{ mA}$ $P_i = 64 \text{ mW}$ $C_i = 5.2 \text{ nF}$ $L_i = \text{negligibly small}$	"ic": $U_i = 15 \text{ V}$ $I_i = 25 \text{ mA}$ $C_i = 5.2 \text{ nF}$ $L_i = \text{negligibly small}$
Galvanic isolation	The 3 outputs are galvanically isolated from the basic device		
Test voltage	DC 3150 V, 2 s		
Rated condition height	Max. 2,000 m mean sea level Use a suitable power supply at an altitude of more than 2,000 m (6,562 ft.) above sea level.	-	-

### 12.8.5 EMC filter module

	Without explosion protection	With Ex protection Ex ia	With Ex protection Ex "ic", "nA", "t"
EMC filter module type C73451-A430-L8 is required for NCS sensor or an external potentiometer. External position sensor (potentiometer or NCS; option) with the following maximum values			
Resistance of the external potentiometer	10 kΩ		
Maximum values when powered by the PROFIBUS basic device	U <sub>o</sub> = 5 V I <sub>o</sub> = 75 mA static I <sub>o</sub> = 160 mA short-term P <sub>o</sub> = 120 mW		U <sub>o</sub> = 5 V I <sub>o</sub> = 75 mA P <sub>o</sub> = 120 mW
Maximum values when powered by other basic devices	U <sub>o</sub> = 5 V I <sub>o</sub> = 100 mA P <sub>o</sub> = 33 mW C <sub>o</sub> = 1 μF L <sub>o</sub> = 1 mH		U <sub>o</sub> = 5 V I <sub>o</sub> = 75 mA ' P <sub>o</sub> = 120 mW C <sub>o</sub> = 1 μF L <sub>o</sub> = 1 mH
Galvanic isolation	Galvanically connected with the basic device		
Test voltage	DC 840 V, 1 s		



### 12.8.6 Non-contacting position sensor

Additional modules	Without explosion protection	With Ex protection Ex "ia"	With Ex protection Ex "ic", "nA"
Actuating range			
• Linear actuator 6DR4004-.N.20	3 to 14 mm (0.12 ... 0.55")		
• Linear actuator 6DR4004-.N.30	10 ... 130 mm (0.39 ... 5.12"); up to 200 mm (7.87") on request		
• Part-turn actuator	30 ... 100°		
Linearity (after corrections made by positioner)	± 1 %		
Hysteresis	± 0,2 %		
Temperature influence (range: rotation angle 120° or stroke 14 mm)	≤ 0.1%/10 K (≤ 0.1%/18 °F) for -20 to 90 °C (-4 to 194 °F) ≤ 0.2%/10 K (≤ 0.2%/18 °F) for -40 to -20 °C (-40 to -4 °F)		
Climate class According to DIN EN 60721-3-4			
• Storage	1K5, but -40 to +90 °C (1K5, but -40 to +176 °F)		
• Transport	2K4, but -40 to +90 °C (2K4, but -40 to +176 °F)		
Vibration resistance			
• Harmonic oscillations (sine wave) according to IEC 60068-2-6	3.5 mm (0.14"), 2 ... 27 Hz, 3 cycles/axis 98.1 m/s <sup>2</sup> (321.84 ft/s <sup>2</sup> ), 27 ... 300 Hz, 3 cycles/axis		
• Permanent shocks according to IEC 60068-2-29	300 m/s <sup>2</sup> (984 ft/s <sup>2</sup> ), 6 ms, 4000 shocks/axis		

Additional modules	Without explosion protection	With Ex protection Ex "ia"	With Ex protection Ex "ic", "nA"
Torque for cable gland nut made of	Plastic	Metal	Stainless steel
	2.5 Nm (1.8 ft lb)	4.2 Nm (3.1 ft lb)	4.2 Nm (3.1 ft lb)
Housing protection type	IP68 according to EN 60529; NEMA 4X / Encl. Type 4X		
For connecting to circuits with the following peak values	-	U <sub>i</sub> = 5 V C <sub>i</sub> = 180 nF L <sub>i</sub> = 922 µH I <sub>i</sub> = 160 mA P <sub>i</sub> = 120 mW	U <sub>i</sub> = 5 V C <sub>i</sub> = 180 nF L <sub>i</sub> = 922 µH

### Certificates and approvals

CE conformity	The applicable directives and standards applied with their revision levels can be found in the EC declaration of conformity on the Internet.
---------------	--

Explosion protection Types of protection	Ex markings	
	ATEX/IECEX	FM
• Intrinsic safety "ia"	Zone 1:  II 2 G Ex ia IIC T6/T4 Gb	IS, Class I, Divison 1, ABCD IS, Class I, Zone 1, AEx ib, IIC
• Intrinsic safety "ic"	Zone 2:  II 3 G Ex ic IIC T6/T4 Gc	-
• Non-sparking "nA"	Zone 2:  II 3 G Ex nA IIC T6/T4 Gc	NI, Class I, Divison 2, ABCD NI, Class I, Zone 2, AEx nA, IIC
Permissible ambient temperature	T4: -40 ... +90 °C (-40 ... +194 °F)	T4: -40 ... +85 °C (-40 ... +185 °F)
	T6: -40 ... +70 °C (-40 ... +158 °F)	T6: -40 ... +70 °C (-40 ... +158 °F)

## 12.8.7 External position sensing system

### 12.8.7.1 Operating conditions for all device versions

Ambient temperature	In hazardous areas, observe the maximum permissible ambient temperature corresponding to the temperature class.
<ul style="list-style-type: none"> <li>Permissible ambient temperature for operation</li> </ul>	-40 ... +90 °C (-40 ... +194 °F)
Degree of protection <sup>1)</sup>	IP66 according to EN 60529 / NEMA 4X
Climate class	According to DIN EN 60721-3-4
<ul style="list-style-type: none"> <li>Storage</li> </ul>	1K5, but -40 ... +90 °C (1K5, but -40 ... +194 °F)
<ul style="list-style-type: none"> <li>Transport</li> </ul>	2K4, but -40 ... +90 °C (2K4, but -40 ... +194 °F)
<ul style="list-style-type: none"> <li>Operation</li> </ul>	4K3, but -40 ... +90 °C (4K3, but -40 ... +194 °F)

<sup>1)</sup> ) Impact energy max. 1 joule.

### 12.8.7.2 Constructional design for all device versions





How does it work?	
<ul style="list-style-type: none"> <li>Range of stroke (linear actuator)</li> </ul>	3 ... 130 mm (0.12 ... 5.12") (angle of rotation of the positioner axis 16 to 90°)
<ul style="list-style-type: none"> <li>Angle of rotation (part-turn actuator)</li> </ul>	30 ... 100°
Mounting method	
<ul style="list-style-type: none"> <li>On the linear actuator</li> </ul>	Using the mounting kit 6DR4004-8V and, if required, an additional lever arm 6DR4004-8L on the actuators as per IEC 60534-6-1 (NAMUR) with a fin, columns, or a plane surface.
<ul style="list-style-type: none"> <li>On the part-turn actuator</li> </ul>	Using the mounting kit 6DR4004-8D on the actuators with fastening plane as per VDI/VDE 3845 and IEC 60534-6-2: The required mount must be provided on the actuator-side.
Material	
<ul style="list-style-type: none"> <li>Enclosure</li> </ul>	Makrolon® glass-fiber reinforced polycarbonate (PC)
Weight, basic device	Approximately 0.9 kg (1.98 lb)
Torque for plastic cable gland nut	2.5 Nm



### 12.8.7.3 Certificates, approvals, explosion protection for all device versions

Electrical data	
For connecting to circuits with the following peak values	$U_i = 5 \text{ V}$ $I_i = 100 \text{ mA}$ $P_i = 160 \text{ mW}$ $C_i = \text{negligibly small}$ $L_i = \text{negligibly small}$

Certificates and approvals	
CE conformity	The applicable directives and standards applied with their revision levels can be found in the EC declaration of conformity on the Internet.

Explosion protection	Ex markings
<b>Explosion protection in accordance with</b>	<b>ATEX</b>
Intrinsic safety "ia"	Zone 1:  II 2 G Ex ia IIC T6/T4 Gb  Zone 21:  II 2 D Ex ia IIIC 110°C Db
Intrinsic safety "ic"	Zone 2:  II 3 G Ex ic IIC T6/T4 Gc
Non-sparking "nA"	Zone 2:  II 3 G Ex nA IIC T6/T4 Gc
<b>Permissible ambient temperature</b>	T4: -40 ... +90 °C (-40 ... +194 °F) T6: -40 ... +60 °C (-40 ... +140 °F)



## Dimension drawings

### 13.1 Positioner with Makrolon enclosure 6DR5..0 and stainless steel enclosure 6DR5..2

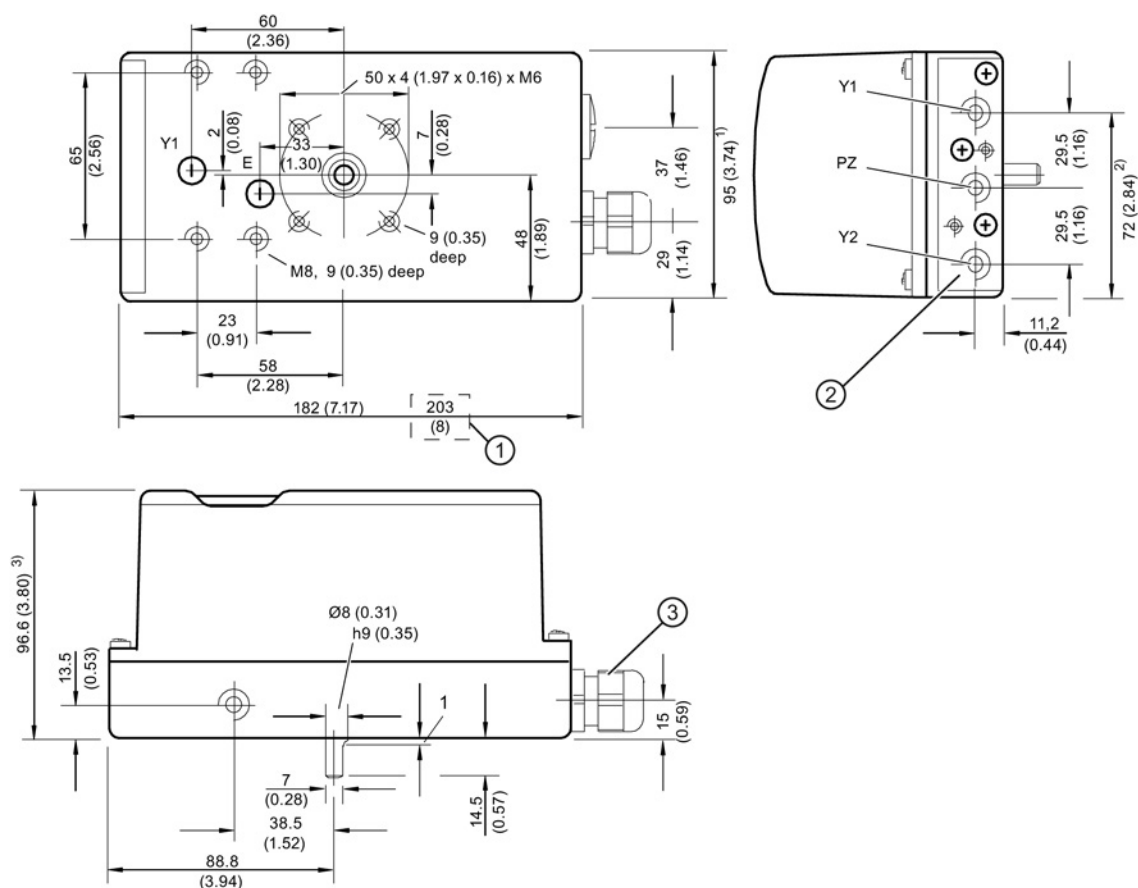

- ① Dimension for electrical connection ½-14 NPT due to adapter: 203 mm (8 inch)
- ② All air connections G¼ or ¼ NPT
- ③ M20 x 1.5 or NPT adapter

Dimensions of stainless steel version (see superscript footnotes in the graphic)

- 1) 99 mm (3.89 inch)
- 2) 74 mm (2.91 inch)
- 3) 98 mm (3.86 inch)

Figure 13-1 Makrolon enclosure version, dimensions in mm (inch)

### 13.2 Terminal strip for positioner with Macrolon enclosure

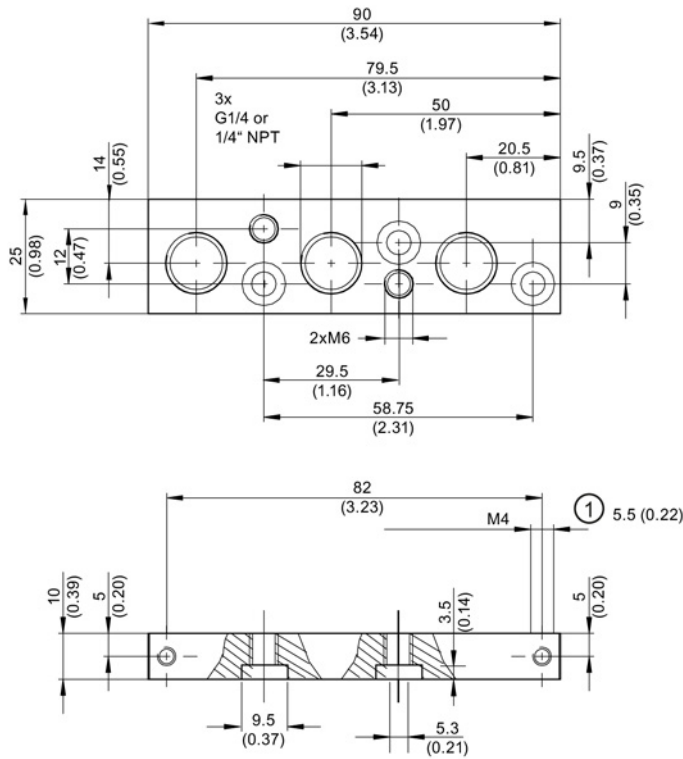

① Thread depth

Figure 13-2 Terminal strip for positioner with Macrolon enclosure, dimensions in mm (inch)

### 13.3 Positioner with aluminum enclosure 6DR5..1

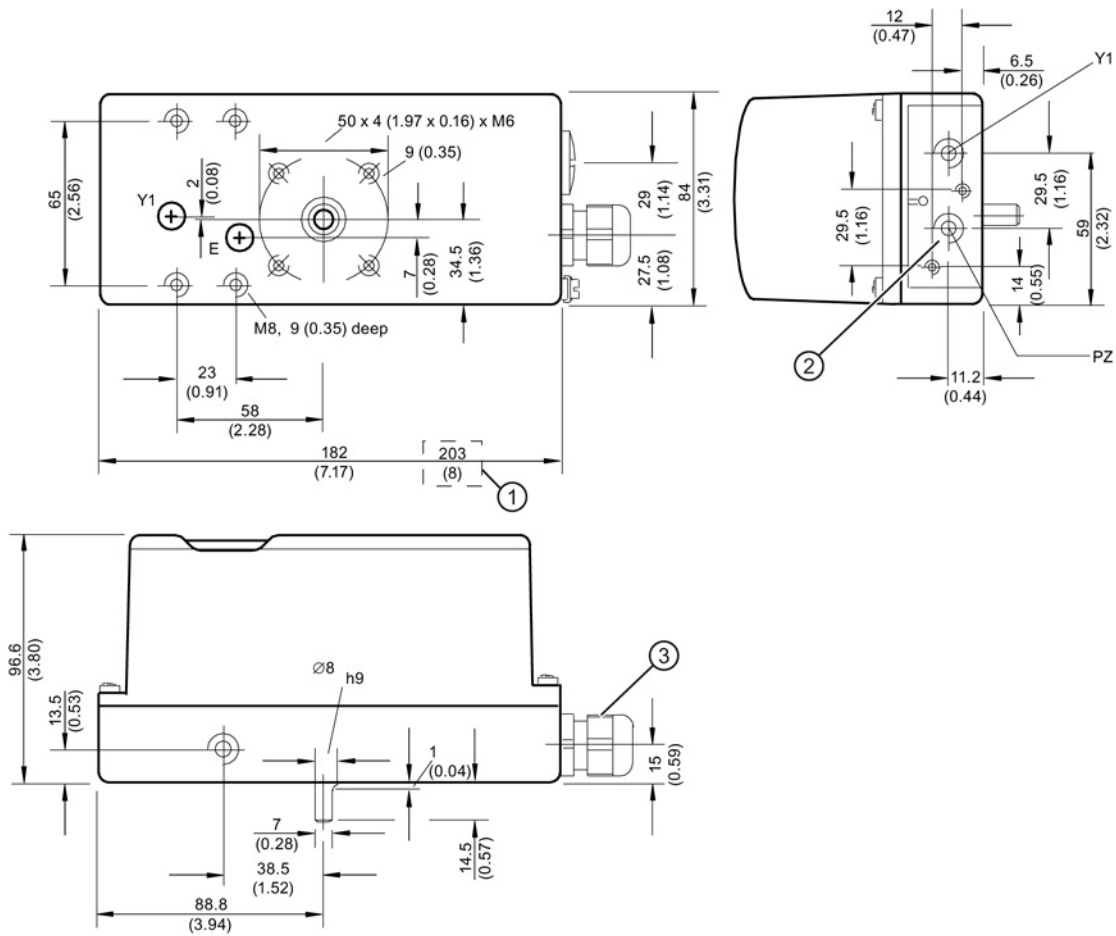

- ① Dimension for electrical connection ½-14 NPT due to adapter: 203 mm (8 inch)
- ② All air connections G¼ or ¼ NPT
- ③ M20 x 1.5 or NPT adapter

Figure 13-3 Aluminum enclosure version, dimensions in mm (inch)

### 13.4 Positioner with flameproof enclosure 6DR5..5

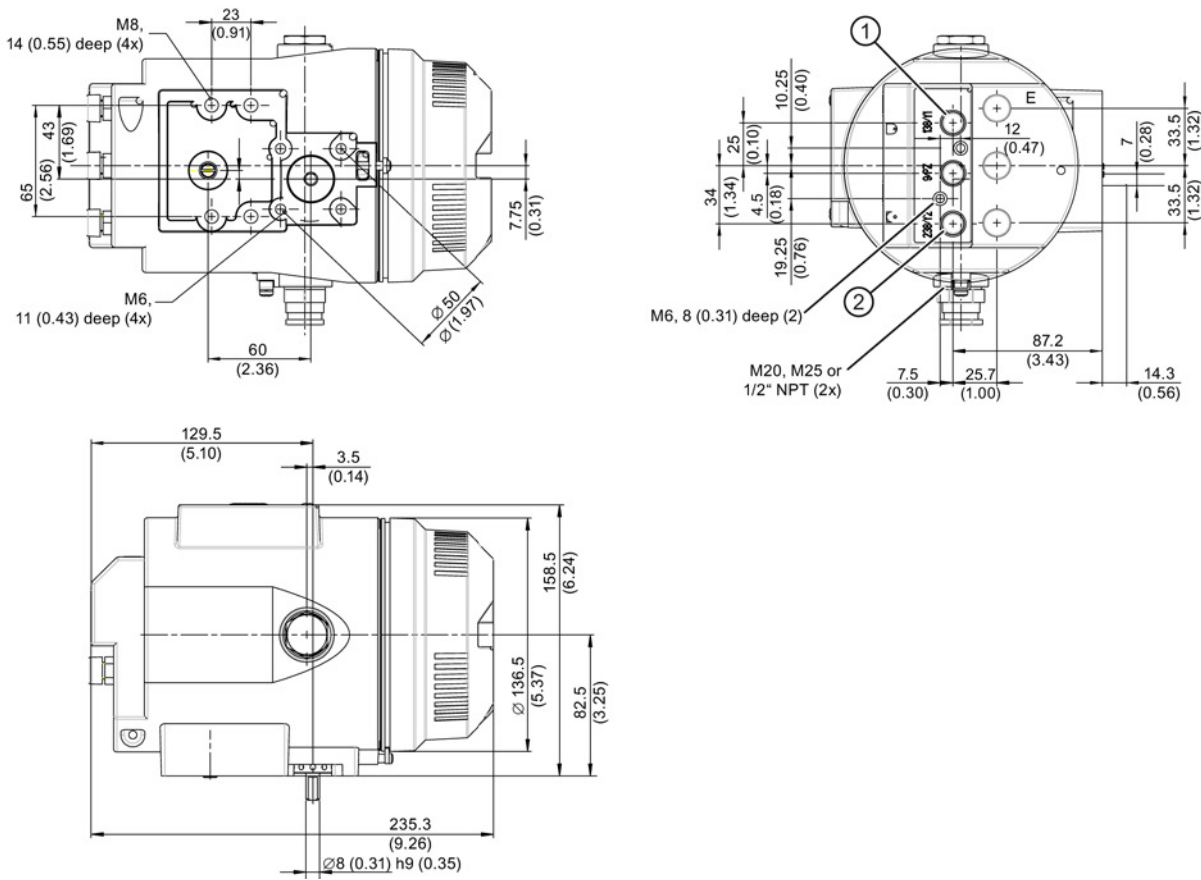

- ① All air connections G $\frac{1}{4}$  or  $\frac{1}{4}$  NPT
- ② Air connection Y2, only with double-acting version

Figure 13-4 Version with flameproof enclosure, dimensions in mm (inch)

## Spare parts/accessories/scope of delivery

### 14.1 Overview

 <b>WARNING</b>
<b>Assembling the components</b> When assembling components, ensure that only those positioners and option modules are combined with each other that are approved for the corresponding operating range. This condition particularly applies to safe operation of the positioner in Zones 1, 2 and 22. It is imperative to observe categories 2 and 3 of the device itself and of its option modules.

#### Basic version

The positioner can be delivered for:

- Double-acting actuators
- Single-acting actuators

The positioner and its option modules are delivered as separate units and with different versions for the operation in:

- Hazardous environments and atmospheres
- Non-hazardous environments and atmospheres

#### Enclosure

The electronic unit with the digital display, position feedback and the pneumatic block are integrated into the enclosure.

The enclosure is available in the following versions:

- Macrolon enclosure for single and double-acting actuators
- Aluminum enclosure for single-acting actuators
- Stainless steel enclosure for single and double-actuators
- Flameproof enclosure for single and double-acting actuators

#### Options

The positioner can be equipped with different option modules. The following modules are normally available:

- I<sub>y</sub> module: two-wire current output 4 to 20 mA for position feedback
- Alarm module: 3 binary outputs and 1 binary input

### 14.1 Overview

- SIA module: one binary output for fault messages, two binary outputs for limit monitors
- Limit contact module with two switches and one alarm output.  
**The limit contact module cannot be used in device versions with flameproof enclosure. Likewise, its use in zones 2 or 22 is not permitted**

### Accessories

- Pressure gauge block: 2 or 3 pressure gauges for single and double-acting positioners
- Mounting flange (NAMUR) for safety pneumatic block
- Mounting kits for linear and part-turn actuators

For separate mounting of positioner and position sensor

- External position sensing system
- Non contacting sensor (NCS)

---

#### **Note**

The version is identified using a special nameplate.

---



## 14.2 Spare parts

	Description	Order no.	For version
	Plastic cover with 4 screws and circumferential sealing ring	C73451-A430-D82	6DR5...
	Aluminum cover with 4 screws and circumferential sealing ring	C73451-A430-D83	6DR5...
	Basic electronics, 2-wire, not Ex, without HART	A5E00082459	6DR50...-N
	Basic electronics 2-wire, Ex, without HART	A5E00082457	6DR50...-E
	Basic electronics, 2-wire, not Ex, with HART	A5E00082458	6DR51...-N
	Basic electronics, 2/3/4-wire, Ex, with HART	A5E00082456	6DR52..
	Basic electronics, 2/3/4-wire, not Ex, without HART	A5E00102018	6DR53...-N
	Basic electronics, PROFIBUS PA, not Ex	A5E00141523	6DR55...-N
	Basic electronics, PROFIBUS PA, Ex	A5E00141550	6DR55...-E
	Basic electronics, FOUNDATION fieldbus, not Ex	A5E00215467	6DR56..
	Basic electronics, FOUNDATION fieldbus, Ex	A5E00215466	6DR56..
	Pneumatic block, single-acting, with seal and screws	C73451-A430-D80	6DR5...
	Pneumatic block, double-acting, with seal and screws	C73451-A430-D81	6DR5...
	Potentiometer (complete)	C73451-A430-D84	6DR5...
	Magnet holder made of fiberglass reinforced polyester including magnet for non contacting position detection for part-turn actuators	A5E00078030	6DR4004-.N.10
	Magnet holder made of anodized aluminum including magnet for non contacting position detection for part-turn actuators	A5E00524070	6DR4004-.N.40

---

**Note**

See Catalog "Field devices for process automation" for additives and possible modules".

---

## 14.3 Scope of delivery of small part sets

### Small part set 1

The small part set 1 with the order number **C73451-A430-D85** contains the following items:



Position	Quantity [unit]
Clamping piece	2
Pick-up bracket	1
Screw DIN 7984 M6x25-A2	2
Spring lock washer DIN 127 B6-SN06031	2
Screw SN 62217 G4x45-/16WN1452-TX-ST	5
Screw SN 62217 G4x14-combi-Torx-TX-ST	5
Screw SN 62217 G5x18-WN1452-T20-A2	3
Screw SN 62217 H5x8-WN1451-TX-A2	2
Screw DIN 7964 M4x16x6-A4-70-F	4
Cable gland MET 20-GR	3
Cable gland MET 20-BL	3
Blind plug M20 SW	3
Slide switch	1
Leaf spring	1
Sign, printed	1

**Small part set 2**

The small part set 2 with the order number **C73451-A430-D86** contains the following items:



Position	Quantity [unit]
Terminal strip C73451-A430-C21	1
Terminal strip C73451-A430-C22	1
Screen, molded	10
O-ring 14-P431ANBR75 (black)	10
O-ring 5.5-P431ANBR75 (black)	6
Screw SN 62217 G5x18-WN1452-T20-A2	3
Attenuator	5
Lip non-return valve	3
Plug 12 PE	10
Seal	3
Installation instructions	1
Sign, printed	1

## 14.4 Scope of delivery of external position detection system

Scope of delivery of external position detection system C73451-A430-D78	
Quantity	Designation
1	DVD with the complete documentation for all variants and accessories
1	External position detection system
1	Gray cable gland
1	Sealing set 2x5 mm for cable gland
1	Plug for sealing set
1	Nameplate for device version <b>without</b> explosion protection

## 14.5 Scope of delivery of mechanical limit switch module

If the mechanical limit switch module was ordered for later installation, then the following components are included in the scope of delivery:

- One mechanical limit switch module with accessories
- DVD with product documentation
- One housing cover with enlarged aperture
- One insulating cover
- Two cable ties
- One set of signs; how these are to be attached depends on the version.

## 14.6 Scope of delivery EMC filter module

### Cable glands and adapters

The EMC filter module is supplied with various cable glands and adapters. The following diagram shows the different variants.

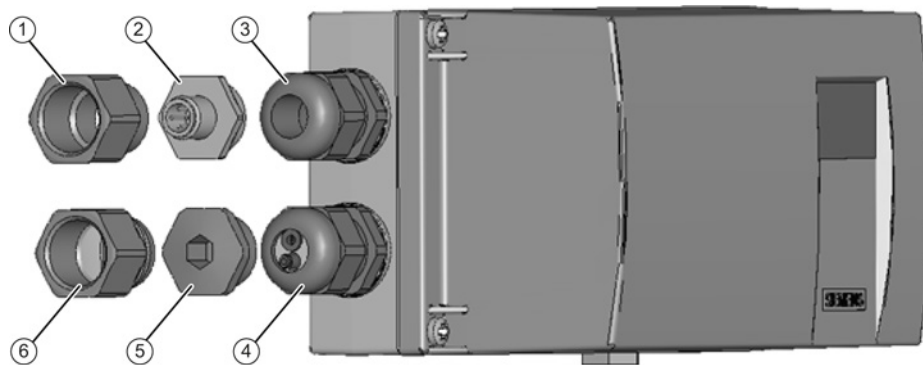

Connections ① to ③ for power supply

- ① Adapter M20 ½-14 NPT for macrolon enclosure
  - 6DR5..0-0.N../ -0.P..
- ② M12 connector for device version with PROFIBUS communication (optional)
  - 6DR55..-0.R../ -0.R..
- ③ Cable gland for connection thread M20x1.5
  - 6DR5...-0.G../ -0.M..



Connections ④ to ⑥ for optional modules

- ④ Cable gland for connection thread M20x1.5 with seal insert
  - 6DR5...-0...1/ -0...2/ -0...3
- ⑤ Dummy plug for device version without optional modules
  - 6DR5...-0...0
- ⑥ Adapter M20 ½-14 NPT for macrolon enclosure with connection thread and cover
  - 6DR5..0-0.N../ -0.P..

Figure 14-1 Positioner with the different cable glands and adapter

**Scope of delivery EMC filter module**

Legend numbers refer to the graphic

	Description
	EMC filter module C73451-A430-L8
	Seal ring
	Cable tie l = 200 mm
①	Adapter M20 ½-14 NPT for macrolon enclosure
②	M12 connector for device version with PROFIBUS communication
③	Cable gland for connection thread M20x1.5
④	Cable gland for connection thread M20x1.5 with seal insert
⑤	Dummy plug for device version without optional modules
⑥	Adapter M20 ½-14 NPT for macrolon enclosure with connection thread and cover
	Adhesive label 9x37 ws

**14.7 Accessories**

For accessories, refer to Catalog FI 01 "Field devices for process automation", for example:

- Option modules
- Non-contacting position sensor (NCS)
- Mounting kits
- Operating software





## Appendix

### A.1 Operation with boosters

#### Introduction

In order to shorten the actuating times, it is possible to use a booster between the positioner and actuator. The booster increases the air performance.

With single-acting positioners you require a booster which must be connected to the air output Y1. With double-acting positioners you require two boosters which must be connected to the air output Y1 and to Y2.

<b>NOTICE</b>
<b>Avoid pressure variations</b>
Make sure that the booster does not result in pressure variations in the supply air $P_z$ on the positioner.

<b>NOTICE</b>
<b>Note when selecting the boosters:</b>
<ul style="list-style-type: none"><li>• Only boosters may be used which do not have a continuous air consumption in the setpoint input.</li><li>• The boosters must not have a follow-up time.</li></ul>
A stable operating state will not be reached if these two points are not observed. All process components involved are subject to faster wear.



#### Procedure

1. Reduce the air performance. To do this, use the restrictors on the positioner.
2. Set the deadband "DEBA" to the largest value permissible for your process.
3. Start the initialization process.
4. If necessary, adjust the actuating times during the initialization process.

If the process value on the display does not remain stable or if a constant manipulated variable cannot be achieved for a constant setpoint, further optimization of the controller data is necessary. This is described in section Optimizing the controller data (Page 109).

#### See also

Sequence of automatic initialization (Page 115)

## A.2 Literature and catalogs

No.	Title	Publisher	Order no.
/1/	Catalog ST 70 <b>SIMATIC</b> Products for Totally Integrated Automation	Siemens AG	E86060-K4670-A111-B1
/2/	Catalog ST 70 N <b>SIMATIC News</b> Products for Totally Integrated Automation	Siemens AG	E86060-K4670-A151-A3
/3/	Catalog ST 80 <b>SIMATIC HMI</b> operation and observation products	Siemens AG	E86060-K4680-A101-B4
/4/	Catalog IK PI <b>Industrial Communication</b>	Siemens AG	Internet address: IK PI catalog ( <a href="http://www.siemens.com/simatic-net/catalogs">www.siemens.com/simatic-net/catalogs</a> ) E86060-K6710-A101-B5
/5/	Catalog FI 01 <b>Field devices for process automation</b>	Siemens AG	E86060-K6201-A101-B1
/6/	Catalog CA 01 <b>The interactive catalog of Industry Automation and Drive Technologies</b>	Siemens AG	E86060-D4001-A500-C7 (DVD)

## A.3 Certificate

The certificates can be found on the enclosed CD and on the Internet under:

Certificates (<http://www.siemens.com/processinstrumentation/certificates>)

## A.4 Technical support

### Technical Support

You can contact Technical Support for all IA and DT products:

- Via the Internet using the **Support Request**:  
Support request (<http://www.siemens.com/automation/support-request>)
- E-mail (<mailto:support.automation@siemens.com>)
- **Phone:** +49 (0) 911 895 7 222
- **Fax:** +49 (0) 911 895 7 223

Further information about our technical support is available on the Internet at  
Technical support (<http://www.siemens.com/automation/csi/service>)

### Service & Support on the Internet

In addition to our documentation, we offer a comprehensive knowledge base on the Internet at:

Service&Support (<http://www.siemens.com/automation/service&support>)

There you will find:

- The latest product information, FAQs, downloads, tips and tricks.
- Our newsletter with the latest information about our products.
- A Knowledge Manager to find the right documents for you.
- Our bulletin board, where users and specialists share their knowledge worldwide.
- Your local contact partner for Industry Automation and Drives Technologies in our partner database.
- Information about field service, repairs, spare parts and lots more under "Services."

### Additional Support

Please contact your local Siemens representative and offices if you have any questions about the products described in this manual and do not find the right answers.

Find your contact partner at:

Partner (<http://www.automation.siemens.com/partner>)

Documentation for various products and systems is available at:

Instructions and manuals (<http://www.siemens.com/processinstrumentation/documentation>)

### See also

SIPART PS2 product information (<http://www.siemens.com/sipartps2>)

Process instrumentation catalog (<http://www.siemens.com/processinstrumentation/catalogs>)



## Abbreviations

Abbreviation	Long form	Meaning
A/D	Analog-to-digital converter	-
AC	Alternating current	Alternating current
AMS	Asset Management Solutions	Communication software from Emerson Process comparable with the PDM
AUT	Automatic	Operating mode
ATEX	Atmosphère explosible	Product and operation directive of European Commission for explosion protection.
CENELEC	Comité Européen de Normalisation Electrotechnique	European committee for electrotechnical standardization
CPU	Central processing unit	Master processor
DC	Direct current	Direct current
DI	Digital Input	Digital input
DIN	Deutsche Industrie Norm	-
DO	Digital Output	Digital output
DTM	Device Type Manager	-
EDD	Electronic Device Description	-
Ex	Explosion protection	-
EMC	Electromagnetic compatibility	-
FDT	Field Device Tool	-
FF	FOUNDATION Fieldbus	Fieldbus of the Fieldbus Foundation
FM	Factory Mutual	American testing agency/insurance company
FW	Firmware	Device-specific software
GSD	Device master data	-
HART®	Highway Addressable Remote Transducer	Communication system for the development of industrial field busses.
IP	International Protection Ingress Protection	International protection types (long form as per DIN) Seepage protection (long form as used in US)
LC	Liquid crystal	Liquid crystal
MAN	Manual	Operating mode
NAMUR	Standards working group for measurement and control technology in the chemicals industry	Association of users in process conductor technology
μC	Microcontroller	One-Chip computer system
NCS	Non-Contacting Position Sensor	No-contact position sensor
NEMA	National Electrical Manufacturers Association	US standards institution National Electrical Manufacturers Association
NPT	National Pipe Thread Taper	Pipe threading for self-sealing threads as per ANSI B.1.20.1

Abbreviation	Long form	Meaning
OPOS interface®	Open Positioner Interface	Standard interface for the connection between a positioner and a pneumatic linear or part-turn actuator
PA	Process Automation	Process automation
PDM	Process Device Manager	Siemens communication software / Engineering tool
PROFIBUS	Process Field Bus	Fieldbus
PTB	Physical Technical Federal Institution	-
SIA	Slit initiator alarm unit	-
SIL	Safety Integrity Level	Safety requirement level as per IEC 61508/IEC 61511
VDE	Verband der Elektrotechnik, Elektronik und Informationstechnik e. V.	Industrial and professional association
VDI	Verein Deutscher Ingenieure e. V.	Technical/scientific association

Abbreviation	Full term in English	Meaning
FIT	Failure in Time	Frequency of failure Number of faults within 10 <sup>9</sup> hours
HFT	Hardware Fault Tolerance	Hardware fault tolerance: Capability of a function unit to continue executing a required function in the presence of faults or deviations.
MooN	"M out of N" voting	Classification and description of the safety-instrumented system in terms of redundancy and the selection procedures used. A safety-instrumented system or part that consists of "N" independent channels. The channels are connected to each other in such a way that "M" channels are in each case sufficient for the device to perform the safety instrumented function. Example: Pressure measurement: 1oo2 architecture. A safety-instrumented system decides that a specified pressure limit has been exceeded if one out of two pressure sensors reaches this limit. In a 1oo1 architecture, there is only one pressure sensor.
MTBF	Mean Time Between Failures	Average period between two failures
MTTR	Mean Time To Restoration	Average period between the occurrence of a fault in a device or system and restoration of functionality
PFD	Probability of Dangerous Failure on Demand	Probability of dangerous failures of a safety function on demand
PFD <sub>AVG</sub>	Average Probability of Dangerous Failure on Demand	Average probability of dangerous failures of a safety function on demand
SFF	Safe Failure Fraction	Proportion of safe failures: Proportion of failures without the potential to bring the safety-instrumented system into a dangerous or non-permissible functional status.

<b>Abbreviation</b>	<b>Full term in English</b>	<b>Meaning</b>
SIL	Safety Integrity Level	The international standard IEC 61508 defines four discrete Safety Integrity Levels (SIL 1 to SIL 4). Each level corresponds to a range of probability for failure of a safety function. The higher the Safety Integrity Level of the safety-instrumented system, the lower the probability that it will not execute the required safety functions.
SIS	Safety Instrumented System	A safety-instrumented system (SIS) executes the safety functions that are required to achieve or maintain a safe status in a system. It consists of sensors, logic unit/control system and final controlling elements.





# Glossary

## Analog

A signal type which represents data using continuously varying, measurable and physical quantities, e.g. current or voltage. Opposite to digital. The range between 4 and 20 mA is often used to transfer analog signals.

## Analog-to-digital converter

An analog-to-digital converter is an interface between the analog environment and the digitally working computers. Only then can the computers be used for measurement and control tasks.

Analog-to-digital converters convert analog input signals to digital signals. Analog measurement data is thus converted into digital information. On the other hand, a digital-to-analog converter converts digital information into analog signals.

## Asset Management Solution (AMS)

Software package by Emerson Process. The AMS Device Manager, which is somewhat similar to the PDM, is a part of the package.

## ATEX

ATEX is the abbreviation of the French term "Atmosphère explosible". ATEX stands for both the directives of the European Community for the field of explosion protection: the ATEX product directive 94/9/EC and the ATEX operation directive 1999/92/EC.

## Auxiliary voltage

Auxiliary voltage is an electric supply or reference voltage that is required by many electric circuits in addition to the standard supply. The auxiliary voltage can be extremely stabilized, have a specific level or polarity and/or other properties having decisive significance for the correct functioning of parts in the circuit. Auxiliary voltage is used, for example, with four-wire systems.

## Conduit piping system

A piping system for the American market, wherein the electric and pneumatic lines are protected by a casing.

## Configuring

See parameter assignment.

### **Cornerstone**

Management software for process instrumentation.

### **Decrement**

From the Latin word *decrementare*, decrease. Decrement is the defined amount of change when decreasing a variable(s) gradually. IT term that refers to a step-by-step decrease in a numeric value.→Increment.

### **Degree of protection**

The degree of protection of a device indicates the extent of protection. The extent of protection includes the safety of persons against coming in contact with live or rotating parts, and the protection of electric resources against the penetration of water, foreign bodies and dust. The degrees of protection of electric machines are indicated by an abbreviation comprising two letters and two numbers (e.g. IP55). The degree of protection is coded using the IP code. The degrees of protection are standardized in DIN EN 60529.

### **Device category 1**

Category 1 devices must be procured such that they ensure an extremely high degree of safety. Devices in this category must ensure an extremely high degree of safety even for faults that occur rarely. Even if two faults occur in the device, it should not lead to ignition. Devices in this category are suitable for use in zone 0.

### **Device category 2**

Category 2 devices must be procured such that they ensure a high degree of safety. Devices in this category must ensure the required degree of safety in case of frequent faults or ones that can be normally expected, e.g. defects in the device, and avoid ignition sources. Devices in this category are suitable for use in zone 1.

### **Device category 3**

Category 3 devices must be procured such that they ensure a normal degree of safety. Devices in this category must ensure the required degree of safety in case of frequent faults or ones that can be normally expected, e.g. defects in the device, and avoid ignition sources. Devices in this category are suitable for use in zone 2.

### **Digital**

Representation of a variable in the form of characters or numbers. The functional course of an originally changeable analog variable is simulated in predefined stages. Predefined values are assigned to these stages. Opposite to "analog".

## EEPROM

EEPROM (Electrically Erasable Programmable Read-Only Memory; literally: elektrisch löschbarer, programmierbarer Nur-Lese-Speicher in German) is a non-volatile electronic memory. EEPROMs are often used when individual data bytes change over long time periods and need to be saved in a manner protected against power failure, e.g. configuration data or operating hours counters.

## Electromagnetic compatibility

Definition as per the EMC law: EMC is the capability of a device to work satisfactorily in the electromagnetic environment without causing electromagnetic interferences that are unacceptable for other devices present in this environment.

## Ex d protection

Type of protection for versions with flameproof enclosures. When the potentially explosive mixtures enter the enclosure of a resource and an ignition source exists in the enclosure. The transfer of the explosion inside the enclosure to the surrounding space must be ruled out.

- d: flameproof enclosure

## Ex ia/ib protection

Types of protection. If potentially explosive mixtures enter the enclosure of a resource, it should not lead to ignition. Demarcation of sparks and increased temperatures.

- ia: intrinsic safety, as per special requirements compliant with EN 50020
- ib: intrinsic safety, as per EN 50020

## Factory Mutual

Industrial property insurer and certification agency in the USA. FM Global is one of the largest industrial insurers in the world who are specialized in the field of technically-supported property insurance. It offers services like product research, testing and certification.

## Failure that causes a dangerous situation

Failure with the potential to switch a safety-instrumented system to a hazardous or non-functioning safety status.

## Fieldbus

A fieldbus is an industrial communication system used to connect a number of field devices with a control device. Field devices include measuring sensors, final controlling elements and actuators.

### **Fieldbus Foundation**

Syndicate of manufacturers of measurement and control systems. The syndicate develops the open fieldbus specifications of the FOUNDATION Fieldbus.

### **Final controlling element**

Converter that converts electric signals into mechanical or other non-electric variables.

### **Firmware**

Firmware (FW) is the software embedded in a chip in electronic devices. It is not like software that is stored on hard disks, CD-ROMs or other mediums. These days, the firmware is mostly stored in a flash memory or an EEPROM. Firmware is software in the hardware, and is thus an intermediate between the software and the hardware. Firmware is normally model-specific. This means that it does not function on other device models and is delivered by the manufacturing company. The corresponding devices cannot function without the firmware. The firmware mostly contains elementary functions to control the device, as well as input and output routines.

### **FOUNDATION Fieldbus**

Fieldbus to connect sensors and final control elements in hazardous areas in accordance with IEC 61158-2. The FOUNDATION Fieldbus uses a common 2-wire cable for data communication and power supply. Data communication and power supply. The FOUNDATION Fieldbus uses bus types such as High Speed Ethernet and Foundation H1.

### **Frequency shifting process**

ENGLISH: Frequency shift keying (FSK)

The frequency shifting process is a simple modulation format in which digital values 0 and 1 are represented by two different frequencies.

### **GSD file**

The file that describes the properties of a PROFIBUS DP slave or a PROFINET IO device.

The GSD file is a database file for PROFIBUS devices. The device manufacturer provides the corresponding GSD file containing the description of device properties. The information in the file can be read using Engineering Tools.

## HART

HART (Highway Addressable Remote Transducer) is a standardized and widely used communication system for erecting industrial fieldbuses. This communication system enables digital communication of multiple participants (field devices) using a common data bus. HART implements the widely used 4/20 mA standard to transfer analog sensor signals. Existing cables of the old system can be used directly and both systems can be operated simultaneously. HART specifies several protocol levels in the OSI model. HART enables transfer of process and diagnostics information and control signals between field devices and superordinated control system. Standardized parameter sets can be used for manufacturer-independent operation of all HART devices.

### HART communicator

Connection with a two-wire line is directly established for the parameter assignment with the HART communicator. For the parameter assignment with a laptop or a PC, a HART modem is connected in between.

### Increment

From the Latin word incrementare, increase. Increment is the defined amount of change when increasing a variable(s) gradually. In informatics, it is referred to as the stepwise increase in a numeric value.→Decrement.

### Initialization

Setting the most important basic parameters. Requirement for commissioning the positioner.

### IP code

The abbreviation IP stands for International Protection as per DIN. In English-speaking countries, IP stands for Ingress Protection.

### Microcontroller

Microcontrollers (also  $\mu$ Controller,  $\mu$ C, MCU) are single-chip computer systems in which almost all components such as master processor, program memory, working memory and input/output interfaces are included in a single chip.

## NAMUR

Standardization association for measurement and control in chemical industries. NAMUR is an association of users of process control technology. The members are mainly the companies from German-speaking countries. The association was formed in Leverkusen in 1949.

## **NEMA**

National Electrical Manufacturers Association. NEMA is a standardization institute in the USA. NEMA was formed in 1926 with the merger of Associated Manufacturers of Electrical Supplies and the Electric Power Club.

## **NEMA 4**

An enclosure standard of the National Electrical Manufacturers Association. The NEMA 4 compliant devices are suitable for use in indoor and outdoor applications. Protection is provided against dust particles, rain as well as spray and splash water.

## **NEMA 4x**

The same protection like NEMA 4. Additional protection of the enclosure from corrosion.

## **Parameter assignment**

Individual parameter settings are specifically changed to adjust the positioner as per the actuator or other requirements. Parameter assignment is carried out after the complete commissioning of the positioner.

## **Piezoelectric effect**

Name of a physical phenomenon. Due to mechanical compression loads on a crystal, an electric potential develops on specific crystal surfaces. In a reverse case, applying an electric field to specific crystal surfaces leads to crystal deformation.

## **Potentially explosive gaseous atmosphere**

Mixture of air, combustible gases, vapors, mists or dusts.

## **Process device manager**

PDM is a Siemens software package for project planning, parameter assignment, commissioning and maintenance of network configuration and field devices. Part of SIMATIC Step7. Is used for configuration and diagnostics.

## **PROFIBUS**

PROFIBUS stands for process fieldbus. PROFIBUS is a vendor-independent standard for networking field devices (e.g. PLCs, actuators, final control elements, and sensors). PROFIBUS is compatible with protocols such as DP (decentralized peripherals), FMS (fieldbus message specification) and PA (process automation).

## PROFIBUS PA

PA is an abbreviation of process automation. PROFIBUS PA is used in process engineering. This fieldbus is used to control the measuring devices using a process control system. This version of PROFIBUS is suitable for hazardous areas of zones 0 and 1. Only a weak current flows through an intrinsically safe circuit in the bus cables, and hence sparks are not generated even in case of a fault.

PA enhances PROFIBUS DP with an intrinsically safe transmission technique compliant with the international standard IEC 61158-2.

## Protocols

Protocols contain information about data formats, time sequences and error handling when exchanging data between computers.

A protocol is a convention about establishing, monitoring and terminating a connection. Different protocols are required for a data connection. Protocols can be assigned to every layer of the reference model. Transport protocols are used for the lower four layers of the reference mode and higher protocols are used for control, data provision and application.

## Safety function

Defined function executed by a safety-instrumented system with the objective of attaining or maintaining a safe status of the system by taking a defined hazardous incident into account.

Example: limit pressure monitoring

## Safety-instrumented system

A safety-instrumented system (SIS) executes safety functions that are required to attain or maintain the safe status in a system. It consists of sensors, logic unit/control system and final controlling elements.

Example: a safety-instrumented system consists of a pressure transmitter, a limit signal indicator and a servo valve.

## Sensor

Converter that converts mechanical or other non-electric variables into electric signals.

## SIL

The international standard IEC 61508 defines four discrete safety integrity levels (SIL) from SIL 1 to SIL 4. Every level indicates a probability range for the failure of the safety function. The higher the SIL of the safety-instrumented system, the higher the probability that the required safety function works. The achievable SIL is determined by the following safety-instrumented characteristics:

- Average probability of dangerous failures of a safety function on demand (PFD<sub>AVG</sub>)
- Hardware fault tolerance (HFT)
- Safe failure fraction (SFF)

### **SIMATIC software**

Programs for process automation (e.g. PCS7, WinCC, WinAC, PDM, Step7).

### **Zero point shutdown**

The zero point shutdown guarantees tight closing of the valve if an input signal is < 2% of the maximum value. The coil current is then set to zero. The zero point shutdown must normally be deactivated to set the minimum coil current

### **Zone 0**

Area in which hazardous potentially explosive gaseous atmospheres build up often, regularly or over long durations during the normal operation of a device.

### **Zone 1**

Area in which potentially explosive gaseous atmospheres build up occasionally during the normal operation of a device.

### **Zone 2**

Area in which a potentially explosive gaseous atmosphere normally never builds up or builds up only for a short while during normal operation of a device.

### **Zone 22**

Zone 22 is an area in which a potentially explosive gaseous atmosphere in the form of a cloud of combustible dust in air never develops or develops only for a short while during normal operation.



# Index

## 6

6DR4004-6A (ATEX/IEC),  
6DR4004-6G (ATEX/IEC/FM/CSA),  
6DR4004-6J (ATEX/IEC),  
6DR4004-6K (with Ex),  
6DR4004-7A (FM/CSA),  
6DR4004-7J (FM/CSA),  
6DR4004-8A (without Ex),  
6DR4004-8G (without Ex),  
6DR4004-8J (without Ex),  
6DR4004-8K (without Ex),

## A

Accessories, 246  
Actuating disk bearings  
  Position, 50  
Actuating pressure  
  Position, 22  
Adapter, 252  
  Position, 53  
Additional Support, 257  
Alarm module  
  Connecting, 78, 87  
  Installation, 57  
  Position, 50, 53  
Amplifier,

## B

Basic device  
  Connecting, 83  
Basic electronics, 247  
  Graphic, 23, 53  
  Position, 22, 50  
Binary input/output,  
Block circuit diagram  
  Functional principle, 26  
Booster, 255  
Buttons  
  Position, 22

## C

C73451-A430-D23,  
C73451-A430-D78,  
Cable gland, 252  
  Position, 22  
Carrier, 38, 148, 156  
Carrier pin, 121, 124, 126, 156  
Certificate, 256  
Certificates, 13  
Certification, 256  
characteristics  
  Safety, 143  
Checking, 142  
Commissioning  
  Cancel, 125  
  Interrupting, 123  
  Manual, 126  
Compressed air,  
Connecting  
  Alarm module, 78, 87  
  Exi, Ex nA, Ex t option modules, 86  
  ly module, 88  
  Limit contact module, 89  
  Mechanical limit switch module, 81  
  NCS, 91  
  Option modules without Ex/with Ex d, 77  
  Position detection system, 92  
  SIA module, 79, 88  
Connecting terminals, 73  
  Option modules, 22  
Connection  
  Pneumatic, 95, 120  
Control air outlet, 231  
Control system, 137  
control valve  
  integrated, 17  
Correct usage,  
Current output,  
Customer Support Hotline, 257

## D

Diagnostics, 197  
  During ongoing operation, 207  
  Extended, 151, 171

Diagnostics guide, 213

Display

Position, 22

Documentation

Edition, 9

Dummy plug

Position, 22

## E

EMC filter module,

Installation, 66

Scope of delivery, 253

Enclosure, 245

Enclosure ventilation, 231

Ex markings, 229, 237, 239

Exhaust air outlet, 231

Position, 22

Extended diagnostics, 171

Parameter, 151

## F

Factory setting

Resetting to ~, 123, 130

Fault identification, 213

Feedback lever bracket

Position, 53

Feedback shaft

Parameter 2.YAGL, 156

Position, 53

Final controlling element,

Firmware, 9

Five-point controller, 17

Flow rate, 231

Friction clutch, 17, 47

Position, 22, 51, 53

## G

gear

switchable, 17

## H

HART module, 27

Hazardous area

Laws and directives, 13

History, 9

Hotline, 257

## I

Improper device modifications, 14

Initialization,

Automatically, 115

Cancel, 132

Interrupting, 130

Installation

Alarm module, 57

ly module, 56

SI A module, 60

Internet, 257

ly module

Connecting, 78, 88

Installation, 56

Position, 50, 53

## L

Label set, 65

Limit contact module, 113

Connecting, 89

Position, 50

Linear actuator

Add-on extensions, 18

Angle of rotation parameter (2.YAGL), 156

Automatic commissioning, 123

Automatic commissioning (flowchart), 115

Automatic initialization parameter (4.INITA), 156

Automatic initialization parameter (5.INITM), 157

Manual commissioning, 126

Mounting, 32

Pneumatic connection, integrated, 95

Range of stroke display parameters (3.YWAY), 156

Single-acting, 18

## M

Maintenance, 142

Manometer

Mounting, 68

Manufacturer serial number, 20

Mechanical limit switch module, 62

Connecting, 81

Mode of operation, 24

Module cover, 73

Position, 50, 53

Motherboard,

Mount

Dimensions, 43

Mounting kit

Linear actuator, 32

**N**

- Nameplate
  - Position, 51
- Natural gas
  - Maximum values for ventilation, 231
  - Operation, 113
- NCS, 66
  - Connecting to EMC filter module, 91

**O**

- Online diagnostics, 207
- Operation
  - Natural gas, 113
- Option modules, 245
  - Connection without Ex/with Ex d, 77
  - Exi, Ex nA, Ex t connection, 86
  - Installation, 51
- Order number, 20

**P**

- Parameter
  - safety-relevant, 141
- Parameters 1 to 5
  - Actuator (1.YFCT), 155
  - Angle of rotation of feedback shaft (2.YAGL), 156
  - Automatic initialization (4.INITA), 156
  - Description, 155
  - Manual initialization (5.INITM), 157
  - Overview, 147
  - Range of stroke display (3.YWAY), 156
- Parameters 6 to 51
  - Overview, 148
- Parameters A to P
  - Overview, 151
- Partial stroke test (PST)
  - Extended diagnostics, 172
- Part-turn actuator
  - Automatic commissioning (flowchart), 115
  - Automatic initialization parameter (4.INITA), 156
  - Automatic initialization parameter (5.INITM), 157
  - Double-acting, 19
  - Mounting, 38
- Pin (feedback lever bracket)
  - Position, 53
- Pneumatic actuator, 24
- Pneumatic block,
  - Position, 50
  - Purging air selector, 120
- Pneumatic connections, 120

- Position detection system
  - External, 92
- Position feedback module,
- Positioner
  - Replacing, 135
- Potentiometer, 66
  - External, 92
- Pressure gauge block, 18
- Printed circuit board,
- Product name, 20
- Purge air switch, 231
- Purging air selector, 120
  - Position, 22
- Pz, 143

**Q**

- Qualified personnel, 15

**R**

- Reading initialization parameters, 135
- Reference stroke time
  - Extended diagnostics, 173
- Regulation system, 17
- Restrictor
  - Position, 22
- Ribbon cable
  - Graphic, 50
  - Position, 53
- Ring gear
  - Position, 53

**S**

- Safety catch
  - Position, 53
- Safety function, 140, 142
  - Checking, 142
- safety-relevant
  - Parameter, 141
- Scope of delivery, 10
  - EMC filter module, 253
- Screen
  - Cleaning of-, 220
- Series connection, 85
- Service, 257
- Settings, 141
- SIA module
  - Connecting, 79, 88
  - Installation, 59

- Position, 50
- SIL 2, 137
- Single-channel operation, 137
- Slot initiator,
- Sound absorber, 231
  - Position, 22
- Split range
  - Connecting, 76, 85
- Starting position
  - Extended diagnostics, 172
- Starting tolerance
  - Extended diagnostics, 172
- Step direction,
- Step magnitude,
- Stroke direction
  - Extended diagnostics, 173
- Stroke magnitude
  - Extended diagnostics, 172
- supply air
  - Position, 22
- Support, 257
- Symbols,
- System integration
  - PDM, 9

## **T**

- Terminal strip, 120
- Test certificates, 13
- Test interval
  - Extended diagnostics, 173
- Transmission ratio selector
  - Position, 22, 50, 53
- Transmitter, 137

## **W**

- Warning label,
- Warning symbols, 13
- Wiring diagram
  - Position, 22, 51

## **Y**

- Y1, 143



## Get more Information:

[www.siemens.com/processautomation](http://www.siemens.com/processautomation)  
[www.siemens.com/sipartps2](http://www.siemens.com/sipartps2)

Siemens AG  
Industry Sector  
Postfach 48 48  
90026 NÜRNBERG  
DEUTSCHLAND

Subject to change without prior notice  
A5E00074631-10  
© Siemens AG 2013



**A5E00074631**



**A5E00074631**

[www.siemens.com/automation](http://www.siemens.com/automation)